

QMS7.5M

SPECIFICATIONS



Frequency	50 Hz
Voltage	230 V
Amperes	28.7 A cont. 32.7 A max.
Power	6.6 kW cont. 7.5 kW max.
Protection	IP23
Insulation	Class H
Voltage accuracy	± 1.5%
Radio interference	Deleted
Lenght	without sound shield : 840 mm [33.1 in] with sound shield : 950 mm [37.4 in]
Width	without sound shield : 489 mm [19.3 in] with sound shield : 540 mm [21.3 in]
Height	without sound shield : 620 mm [24.4 in] with sound shield : 715 mm [28.1 in]
Dry weight	without sound shield : 224 kg [493.8 lbs] with sound shield : 271 kg [597.5 lbs]

Engine base	Kubota
Cooling system	Seawater pump with rubber impeller
Closed cooling	Heat exchanger
Cylinders	3 in line
Start (cold temperature)	Super Glow System
Exhaust connexion	50 mm [2 in]
Fuel consumption at full load	2.5 l/h [0.66 gal US/h]
Sea water pump connexion	25 mm [1 in]
Fuel pump - Max suction height	std pump : 0.5 m [19.7 in] with add. pump : 1.8 m [70.9 in]
Engine operating angle	15° cont. 30° max.
Fuel connexion	8 mm [0.3 in]

QMS7.5M

7.5 kW max. at 1500 rpm

TECHNICAL DESCRIPTION

ENGINE BASE

- 4 strokes Diesel engine tested in all marine or industrial applications throughout the world.
- Engine block in cast iron type tunnel and timing gear.

INJECTION AND COMBUSTION SYSTEM

- The Super Glow System comes as standard equipment to start the engine in cold temperatures.
- The E-TVCS injection system produces an ideal air/fuel mixture by creating three vortices in the combustion chamber. The combustion efficiency is improved, resulting in low fuel consumption.

COOLING SYSTEM

- Cooling is ensured by heat exchange between coolant and seawater in an heat exchanger, or via a Keel Cooling system.
- Seawater pump with rubber impeller.

GENERATOR

- Delivering a continuous power of 6.6 kW and able to provide up to 7.5 kW
- IP23 protection

STANDARD EQUIPMENT

- Extension delivered by meter
- Closed cooling with heat exchanger
- Wet exhaust
- 12V Single-pole electrical system
- Safety shutdowns on low oil pressure and high coolant temperature
- Eco GE panel ¹
- Rubber mounts
- Oil drain pump mounted on the engine ¹

OPTIONAL EQUIPMENT

- Seawater hoses
- Seawater filter
- Siphon breaker
- Fuel feed system piping
- Exhaust system
- Fuel prefilter
- Keel Cooling ²
- Vertical dry exhaust ²
- 12V Double-pole electrical system ²
- Luxe GE panel (instead of Eco GE panel)
- Additional electric fuel feed pump

¹ Optional in version with sound enclosure

² Not available in version with sound enclosure

INSTRUMENT PANEL

ECO GE



LUXE GE



- Start and stop buttons
- Low oil pressure warning light
- Coolant temperature warning light
- Preheat warning light
- Battery charge warning light
- Oil pressure indicator *
- Coolant temperature indicator *

*Only with Luxe GE

MAIN COMPONENTS

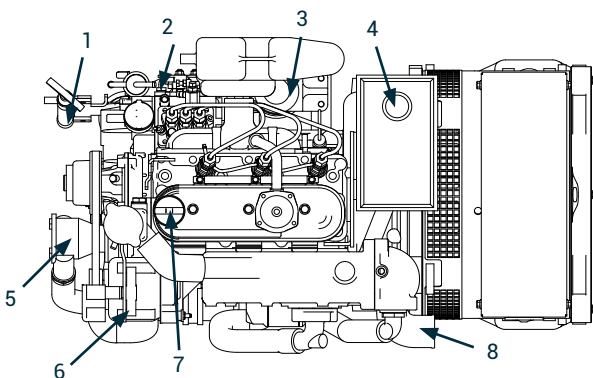

1. Oil drain pump **
2. Fuel feed pump
3. Fuel filter
4. Expansion tank
5. Seawater pump

6. Oil filter
7. Oil filter port
8. Exhaust elbow

** Optional in version with sound enclosure (supplied loose)

SOUND ENCLOSURE (OPTIONAL)

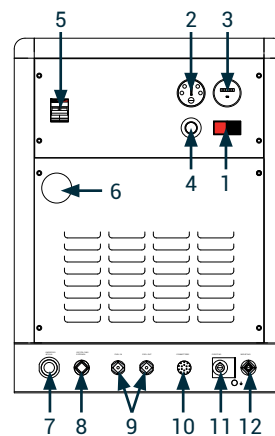

1. Start & Stop buttons
2. Warning displays
3. Hourmeter
4. Emergency stop
5. Circuit breaker
6. Exhaust outlet
7. Seawater connection
8. Power cable connection
9. Fuel connection
10. Dashboard connection
11. Battery connection +
12. Battery connection -

NANNI INDUSTRIES S.A.S.

11, Avenue Mariotte - Zone Industrielle
33260 La Teste - France
Tel: +33 (0)5 56 22 30 60
Fax: +33 (0)5 56 22 30 79

Technical data according to ISO 8528. This document is not contractual. Nanni reserves the right to modify any of the characteristics stated in this document without notice, in a constant effort to improve the quality of its products. Images and illustrations may show non standard equipments. All combination of equipment & accessory are not available.

DGBXXC01101