

**OPERATION &
MAINTENANCE MANUAL**

**5.7L, 7.4L and 8.2L
BLUEWATER INBOARDS**

Identification Record

PLEASE RECORD THE FOLLOWING INFORMATION:

1. _____
Engine Model, Horsepower

2. _____
Engine Serial Number

3. _____
Transmission Models Transmission Serial Number

4. _____
Propeller Number Pitch Diameter

5. _____
Hull Identification Number (HIN) Purchase Date

6. _____
Boat Manufacturer Boat Model Length

Serial Numbers

The serial numbers are the manufacturer's keys to numerous engineering details which apply to your MerCruiser power package. When contacting your Authorized MerCruiser Dealer about service, always specify model and serial numbers.

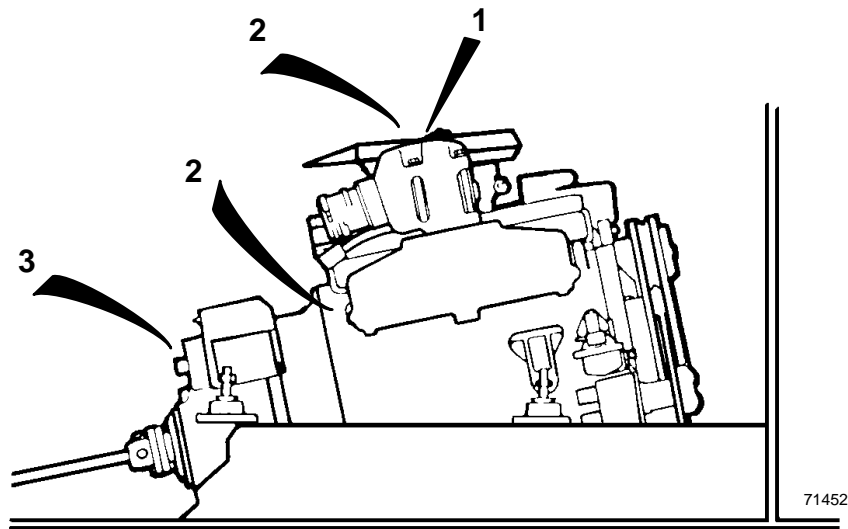

Table of Contents

	Page
Welcome!	3
Read This Manual Thoroughly	3
Lanyard Stop Switch	4
Safe Boating Suggestions	5
Protecting People In The Water	6
While You Are Cruising	6
While Boat Is Stationary	6
High-speed And High-Performance Boat Operation	6
Conditions Affecting Operation	7
Important Information	11
Operation	16
Instrumentation	17
Overload Protection Electrical System	17
Audio Warning System	19
Remote Controls (Panel Mounted)	21
Remote Controls (Two Lever)	21
Remote Controls (Console Mounted)	23
Starting, Shifting and Stopping	24
Operation Chart	25
Specifications	26
Fuel Recommendations	26
Engine	28
Tune-Up	28
Capacities	29
Maintenance	30
Maintenance Products	31
Maintenance Chart	32
Scheduled Maintenance To Be Performed By Owner / Operator	32
Scheduled Maintenance To Be Performed By Dealer	33
Checking Fluid Levels	35
Changing Fluids	37
Lubrication	39
Flushing Cooling System	41
Cleaning Seawater Section Of Heat Exchanger - Closed Cooled Models Only	41
Drive Belts	43
Flame Arrestor And Crankcase Vent Hoses	45
Fuel Pump Sight Tube Inspection	45
Water Separating Fuel Filter (If So Equipped)	45
Engine Alignment	47

	Page
Emissions	48
Installing Test Probes	51
Miscellaneous Maintenance	52
Battery	52
Bottom Of Boat	52
Antifouling Paints	52
Inspection And Maintenance	52
Cold Weather or Extended Storage	53
Power Package Layup	53
Troubleshooting	59
Wiring Diagrams	62
Quicksilver Instrumentation	62
Engine (5.7L, 7.4L and 8.2L)	63
Water Flow Diagrams	64
Warranty Information	69
Owner Warranty Registration	69
International Owner Registration	69
Warranty Policies	70
MerCruiser Limited Warranty - Gasoline Engines	70
MerCruiser International Warranty - Gasoline Engines	71
3 Year Limited Warranty Against Corrosion Failure	72
Warranty Coverage	73
Direct Sale By Owner	74
United States and Canada Only	74
Local Repair Service	75
Service Away From Home	75
Parts and Accessories Inquiries	75
Resolving a Problem	76
General Maintenance Parts	80
Literature Order Form	81

The description and specifications contained herein were in effect at the time this guide was approved for printing. Mercury Marine, whose policy is one of continuous improvement, reserves the right to discontinue models at any time, or to change specifications or designs, without notice and without incurring obligation.

Mercury Marine
Fond du Lac, Wisconsin, U.S.A.

©1996, Brunswick Corporation
The following are registered trademarks of Brunswick Corporation: Autoblend,
Jet-Prop, Mariner, Merc, MerCathode, MerCruiser, Mercury, Mercury Marine,
Quicksilver, Ride-Guide, and Thruster.

Printed in U.S.A.

Welcome!

You have selected one of the finest marine power packages available. It incorporates numerous design features to assure operating ease and durability.

With proper care and maintenance, you will thoroughly enjoy using this product for many boating seasons. To ensure maximum performance and carefree use, we ask that you thoroughly read this manual.

The Operation and Maintenance Manual contains specific instructions for using and maintaining your product. We suggest that this manual remain with the product for ready reference whenever you are on the water.

Thank you for purchasing one of our MerCruiser products. We sincerely hope your boating will be pleasant!

Consumer Affairs Department

Read This Manual Thoroughly

IF YOU DON'T UNDERSTAND ANY PORTION, CONTACT YOUR DEALER FOR A DEMONSTRATION OF ACTUAL STARTING AND OPERATING PROCEDURES.

NOTICE

Throughout this publication, and on your power package, **WARNINGS** and **CAUTIONS**, accompanied by the International Hazard Symbol , may be used to alert the installer/user to special instructions concerning a particular service or operation that may be hazardous if performed incorrectly or carelessly. **Observe them carefully.**

These "Safety Alerts" alone cannot eliminate the hazards that they signal. Strict compliance with these special instructions while performing the service, plus "common sense" operation, are major accident prevention measures.

WARNING

WARNING-Hazards or unsafe practices which could result in severe personal injury or death.

CAUTION

CAUTION-Hazards or unsafe practices which could result in minor personal injury or product or property damage.

IMPORTANT: - Indicates information or instructions that are necessary for proper operation and /or maintenance.

WARNING

The operator (driver) is responsible for the correct and safe operation of the boat, the equipment aboard and the safety of all occupants aboard. We strongly recommend that the operator read this Operation and Maintenance Manual and thoroughly understand the operational instructions for the power package and all related accessories before the boat is used.

Lanyard Stop Switch

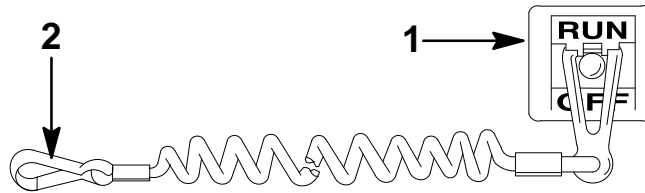

74608

1 Some boats come equipped with a lanyard stop switch. A lanyard stop switch can also be installed as an accessory. The purpose of this switch is to turn off the engine ignition whenever the operator (when attached to the lanyard) moves far enough away from the operator's position to activate the switch.

2 The lanyard is a cord usually between 4 and 5 feet (1220 and 1524 mm) in length when stretched out with an element on one end made to be inserted into the switch and a metal snap on the other end for attaching to the operator. It is coiled to make its at rest condition as short as possible so as to minimize the likelihood of lanyard entanglement with nearby objects. It is made as long as it is in its stretched condition to minimize the likelihood of accidental activation should the operator choose to move around in an area close to the normal operator's position. If for any reason it is desired to have a shorter functional lanyard, this may be accomplished by using up length in the way the lanyard and clip are attached to the operator (such as wrapping the lanyard around the operator's wrist or leg) or by tying a simple knot in the lanyard.

Read the Safety Warning on this page and the following page before electing to install, use, or not to use such a switch.

⚠ WARNING

The following advantages and disadvantages of a lanyard stop switch should be considered before electing to use, or not to use, such a switch.

ADVANTAGES: The purpose of a lanyard stop switch is to stop the engine ignition whenever the operator (when attached to the lanyard) moves far enough away from the operator's position to activate the switch. This would occur if the operator falls or moves within the boat a sufficient distance from the operator's position. This type of accident is most likely in certain types of boats such as low-sided boats, and high-performance boats, It is also likely as a result of poor operating practices such as sitting on the back of the seat at planing speeds, standing at planing speeds, operating at high speeds in shallow or obstacle-infested waters, releasing your grip on a steering wheel that is pulling in one direction, drinking and driving, or daring, high-speed boat maneuvers.

DISADVANTAGES: Inadvertent activation of the switch is also a possibility. This could cause any, or all, of the following potentially hazardous situations:

1. Loss of balance and falling forward of unstable boat passengers - a particular concern in bow rider type boats.
2. Loss of power and directional control in heavy seas, strong current or high winds.
3. Loss of control when docking.

While activation of the lanyard stop switch will result in immediate power shut-down, a boat can continue to coast for some distance depending upon the velocity and degree of any turn at shut-down. However, the boat will not complete a full circle. While the boat is coasting, it can cause injury to anyone in the boat's path as seriously as the boat would when under power.

As we cannot possibly know of and advise the boating public of all conceivable boat/motor types and/or poor operating practices, the final decision of whether to use a lanyard stop switch rests with you, the owner/driver.

We strongly recommend that other occupants be instructed on proper starting and operating procedures should they be required to operate the engine and boat in an emergency.

Safe Boating Suggestions

In order to safely enjoy the waterways, familiarize yourself with local and other governmental boating regulations and restrictions, and consider the following suggestions.

- **Know and obey all nautical rules and laws of the waterways.** Boat operators should complete a boating safety course. Courses are offered in the U.S.A. by (1) The U.S. Coast Guard Auxiliary, (2) The Power Squadron, (3) The Red Cross and (4) your state or provincial boating law enforcement agency. Inquiries may be made to the Boating Hotline, 1-800-368-5647 or the Boat U.S. Foundation information number 1-800-336-BOAT.

We strongly recommend that all powerboat operators attend one of these courses.

You should also review the NMMA Sources of Waterway Information booklet. It lists regional sources of safety, cruising and local navigation and is available at no charge by writing to:

Sources of Waterway Information

National Marine Manufacturers Association

410 N. Michigan Avenue

Chicago, IL 60611 U.S.A.

- **Perform safety checks and required maintenance.** Follow a regular schedule and ensure that all repairs are properly made.
- **Check safety equipment on board.** Here are suggestions of the types of safety equipment to carry when boating:

- (1) Approved fire extinguisher(s); paddle or oar.
- (2) Signal devices: flashlight, rockets or flares, flag and whistle or horn.
- (3) Spare propeller, thrust hubs and an appropriate wrench.
- (4) Tools for necessary minor repairs; first aid kit and book.
- (5) Anchor and extra anchor line; water-proof storage containers.
- (6) Manual bilge pump and extra drain plugs; compass and map or chart of area.
- (7) Spare operating equipment; batteries, bulbs, fuses, etc.
- (8) Transistor radio
- (9) Drinking water

- **Know signs of weather change and avoid foul weather and rough-sea boating.**
- **Tell someone where you are going and when you expect to return.**
- **Passenger boarding.** Stop the engine whenever passengers are boarding, unloading or are near the back (stern) of the boat. Just shifting the drive unit into neutral is not sufficient.
- **Use personal flotation devices.** Federal Law requires that there be a U. S. Coast Guard approved, wearable-type life jacket (personal flotation device), correctly sized and readily accessible for every person on board, plus a throwable cushion or ring. We strongly advise that everyone wear a life jacket at all times while in the boat.
- **Prepare other boat operators.** Instruct at least one person on board in the basics of starting and operating the engine and boat handling in case the driver becomes disabled or falls overboard.
- **Do not overload your boat.** Most boats are rated and certified for maximum load (weight) capacities (refer to your boat capacity plate). When in doubt, contact your dealer or the boats manufacturer. Know your boat's operating and loading limitations.
- **Make sure everyone in the boat is properly seated.** Don't allow anyone to sit or ride on any part of the boat that was not intended for such use. This includes backs of seats, gunwales, transom, bow, decks, raised fishing seats, any rotating fishing seat; anywhere that sudden unexpected acceleration, sudden stopping, unexpected loss of boat control or sudden boat movement could cause a person to be thrown overboard or into the boat.
- **Never be under the influence of alcohol or drugs while boating (it is the law).** They impair your judgment and greatly reduce your ability to react quickly.

- **Know your boating area and avoid hazardous locations.**
- **Be alert.** The operator of the boat is responsible by law to “maintain a proper lookout by sight (and hearing).” The operator must have an unobstructed view particularly to the front. No passengers, load, or fishing seats should block the operators view when operating the boat above idle or planing transition speed. Watch “the other guy,” the water and your wake.
- **Never drive your boat directly behind a water skier in case the skier falls.** As an example, your boat traveling at 25 miles per hour (40 km/hr) in 5 seconds will overtake a fallen skier who was 200 feet in front of you.
- **Watch fallen skiers.** When using your boat for water skiing or similar activities, always keep a fallen or down skier on the operator’s side of the boat while returning to attend the skier. The operator should always have the down skier in sight and never back up to the skier or anyone in the water.
- **Report accidents.** Boat operators are required by law to file a Boating Accident Report with their state boating law enforcement agency when their boat is involved in certain boating accidents. A boating accident must be reported if (1) there is loss of life or probable loss of life, (2) there is personal injury requiring medical treatment beyond first aid, (3) there is damage to boats or other property where the damage value exceeds \$500.00 or (4) there is complete loss of the boat. Seek further assistance from local law enforcement.

CA282

Protecting People In The Water

While You Are Cruising

It is very difficult for a person standing or floating in the water to take quick action to avoid a boat heading in his/her direction even at slow speed.

Always slow down and exercise extreme caution any time you are boating in an area where there might be people in the water.

Whenever a boat is moving (coasting) and the drive unit is in neutral position, there is sufficient force by the water on the propeller to cause the propeller to rotate. This neutral propeller rotation can cause serious injury.

While Boat Is Stationary

Shift the drive unit into neutral and shut off the engine before allowing people to swim or be in the water near your boat.

WARNING

Stop your engine immediately whenever anyone in the water is near your boat. Serious injury to the person in the water is likely if contacted by a rotating propeller, a moving boat, a moving gear case, or any solid device rigidly attached to a moving boat or gear case.

CA283

High-speed And High-Performance Boat Operation

If your boat is considered a high-speed or high-performance boat with which you are unfamiliar, we recommend that you never operate it at its high speed capability without first requesting an initial orientation and familiarization demonstration ride with your dealer or an operator experienced with your boat. For additional information, obtain a copy of our “Hi-Performance Boat Operation” booklet (Part Number 90-86168--3) from your dealer, distributor, or Mercury Marine.

Conditions Affecting Operation

Weight Distribution

Positioning of weight (passengers and gear) inside the boat has the following effects:

Shifting weight to rear (stern) will:

- Generally increases speed and engine RPM.
- At extremes can cause boat to porpoise.
- Causes bow to bounce in choppy water.
- Increases danger of following wave splashing into boat when coming off plane.

Shifting weight to front (bow) will:

- Improve ease of planing.
- Improve rough water ride.
- At extremes, can cause boat to veer back and forth (bow steer).

Bottom Of Boat

To maintain maximum speed, the following conditions of the boat bottom should be observed.

- Clean, free of barnacles and marine growth.
- Free of distortion; nearly flat where it contacts the water.
- Straight and smooth, fore and aft.

Marine vegetation may accumulate when boat is docked. This growth must be removed before operation; it may clog water inlets and cause engine to overheat.

Propeller Selection

IMPORTANT: Installed propeller must allow engine to run at its specified maximum wide-open-throttle revolutions per minute (RPM). Use an accurate service tachometer to verify engine operating RPM.

It is the responsibility of the boat manufacturer and/or the selling dealer to equip the power package with the correct propeller(s). Specified engine wide-open-throttle (WOT) and operating RPM range are listed in "SPECIFICATIONS".

IMPORTANT: The engines covered in this manual are equipped with an RPM rev-limiter that is set to an upper (or limited) RPM amount. This limit is slightly above the normal operating range of the engine and is designed to help prevent damage from excessive engine RPM. Once the RPM drop into the recommended operating RPM range normal engine operation resumes.

Select a propeller that will allow the engine power package to operate at or near the top end of the recommended wide-open-throttle operating RPM range with a normal load. Generally, there is a 100 RPM difference between 1 inch changes in propeller diameter or pitch.

If full throttle operation is below the recommended range, the propeller must be changed to prevent loss of performance and possible engine damage. On the other hand, operating an engine above the recommended operating RPM range will cause higher than normal wear and/or damage.

After initial propeller selection, the following common problems may require that the propeller be changed to a lower pitch:

- Warmer weather and greater humidity cause an RPM loss.
- Operating in a higher elevation causes an RPM loss.
- Operating with a damaged propeller or dirty boat bottom causes an RPM loss.
- Operating with increased load (additional passengers, pulling skiers, etc.)

For better acceleration, such as is needed for water skiing, use the next lower pitch propeller. However, do not operate at full throttle when using the lower pitch propeller but not pulling skiers.

How Elevation and Climate Affect Performance

Elevation has a very noticeable effect on the wide-open-throttle power of an engine. Since air (containing oxygen) gets thinner as elevation increases, the engine begins to starve for air. Humidity, barometric pressure and temperature do have a noticeable effect on the density of air. Heat and humidity thin the air. This condition can become particularly annoying when the propeller testing was done on a cool, dry day. Then later; on a hot, sultry day, the boat doesn't seem to have the same performance.

Although some performance can be regained by dropping to a lower pitch propeller, the basic problem still exists. In some cases, a gear ratio change to more reduction is possible and very beneficial.

Summer conditions of high temperature, low barometric pressure and high humidity all combine to reduce the engine power. This, in turn, is reflected in decreased boat speeds, as much as 2 or 3 miles per hour in some cases. Nothing will regain this speed for the boater, but the coming of cool, dry weather.

In pointing out the practical consequences of weather effects, an engine running on a hot, humid, summer day, may encounter a loss of as much as 14% of the horsepower it would produce on a dry, brisk spring or fall day. With the drop in available horsepower, this propeller will, in effect, become too large. Consequently, the engine operates at less than its recommended RPM. This will result in further loss of horsepower at the propeller with another decrease in boat speed. This secondary loss, however, can be somewhat regained by switching to a lower-pitch propeller that allows the engine to again run at recommended RPM.

For boaters to realize optimum engine performance under changing weather conditions, it is essential that the engine be propped to allow it to operate at or near the top end of the recommended maximum RPM range at wide-open-throttle with a normal boat load.

Not only does this allow the engine to develop full power, but equally important is the fact that the engine also will be operating in an RPM range that discourages damaging detonation. This, of course, enhances overall reliability and durability of the engine.

THIS PAGE IS INTENTIONALLY BLANK

Important Information

Operation And Maintenance

OWNER/OPERATOR RESPONSIBILITIES

It is the operator's responsibility to perform all safety checks; to ensure that all lubrication and maintenance instructions are complied with for safe operation and to return the unit to an Authorized MerCruiser Dealer for a periodic checkup.

Normal maintenance service and replacement parts are the responsibility of the owner/operator and as such, are not considered defects in workmanship or material within the terms of the warranty. Individual operating habits and usage contribute to the need for maintenance service.

Proper maintenance and care of your power package will assure optimum performance and dependability, and will keep your overall operating expenses at a minimum. See your Authorized MerCruiser Dealer for service aids.

DEALER RESPONSIBILITIES

In general, a dealer's responsibilities to the customer include predelivery inspection and preparation such as:

- Make sure that the boat is properly equipped.
- Prior to delivery, make certain that the MerCruiser power package and other equipment are in proper operating condition.
- Make all necessary adjustments for maximum efficiency.
- Familiarize the customer with the on-board equipment.
- Explain and demonstrate the operation of the power package and boat.
- At the time of delivery, the dealer should provide you with a copy of a Predelivery Inspection Checklist.
- Your selling dealer should fill out the Warranty Registration Card completely and mail it to the factory immediately upon sale of the new product.

Launching And Boat Operation Care

CAUTION

During launching from a trailer, if the unloading ramp is steep or the trailer bed must be tilted, the boat may enter the water rapidly and at a steep angle. This may force water through the exhaust system into the cylinders. The more weight on the transom, the more likely this is to occur.

Slowing down rapidly or stopping suddenly may cause a following wave to "swamp" the transom. In this instance, water may enter the cylinders through the exhaust system.

When backing up rapidly, the same situation may occur as stated in the preceding paragraph.

In any of these situations, water entering the engine could cause severe damage to internal parts. Refer to "Attention Required After Submersion".

CA318

Freezing Temperature Operation

IMPORTANT: If boat is operated during periods of freezing temperature, precautions must be taken to prevent freezing damage to power package. Refer to “COLD WEATHER or EXTENDED STORAGE” for draining instructions. Damage caused by freezing **IS NOT** covered by the MerCruiser Limited Warranty.

CA331

Emissions Information

Your engine may be equipped with special design features and special tuning to minimize the emission output from the engine. If so, it is very important that you strictly adhere to the following:

- Recommended maintenance schedules particularly the ignition system.
- Proper engine tuning procedures to ensure these features remain in good operating order.
- Proper steps to maintain the engine within specifications.

Use only MerCruiser replacement parts to ensure compliance with emission regulations.

IMPORTANT: The testing dealer or agency will be equipped with the appropriate test equipment and adapters for this engine. The only item that must be supplied by the boat owner/operator is the exhaust elbow test probes. These test probes should have been provided with your power package. They should be carried aboard your boat at all times. Refer to “Emissions Testing” procedure found later in this manual.

Attention Required After Submersion

- Before recovery, contact a MerCruiser Dealer.
- After recovery, immediate service by an Authorized MerCruiser Dealer is required to prevent serious damage to power package.

CA21

Stolen Power Package

If your power package is stolen, immediately advise the local authorities and Mercury Marine of the model and serial number(s) and to whom the recovery is to be reported. This “Stolen Motor” information is placed into a file at Mercury Marine to aid authorities and dealers in recovery of stolen motors.

Replacement Service Parts

WARNING

Electrical, ignition and fuel system components on MerCruiser gasoline power packages are designed and manufactured to comply with U.S. Coast Guard rules and regulations to minimize risks of fire or explosion.

Use of replacement electrical, ignition or fuel system components, which do not comply to these rules and regulations, could result in a fire or explosion hazard and should be avoided.

When servicing the electrical, ignition and fuel systems, it is extremely important that all components are properly installed and tightened. If not, any electrical or ignition component would permit sparks to ignite fuel vapors from fuel system leaks, if they existed.

Marine engines are expected to operate at or near full-throttle for most of their life. They are also expected to operate in both fresh and saltwater environments. These conditions require numerous special parts. Care should be exercised when replacing marine engine parts as specifications are quite different from those of the standard automotive engine.

For example, one of the most important, and probably the least suspected special replacement part, is the cylinder head gasket. Since saltwater is highly corrosive, the steel-type automotive head gasket cannot be used. A marine engine head gasket uses special materials to resist corrosive action.

Since marine engines must be capable of running at or near maximum RPM much of the time, special valve springs, valve lifters, pistons, bearings, camshafts and other heavy-duty moving parts are required for long life and peak performance.

These are but a few of the many special modifications that are required in MerCruiser marine engines to provide long life and dependable performance.

Do-It-Yourself Maintenance Suggestions

If you are one of those persons who likes to do-it-yourself, here are some suggestions for you.

- Present-day marine equipment, such as your MerCruiser power package, are highly technical pieces of machinery. Electronic ignition and special carburetion provide greater fuel economies, but also are more complex for the untrained mechanic.
- Do not attempt any repairs which are not covered in this manual unless you are aware of the precautions (“Cautions” and “Warnings”) and procedures required. Your safety is of our concern.
- If you attempt to service the product yourself, we suggest you order the service manual for that model. The service manual outlines the correct procedures to follow. It is written for the trained mechanic, so there may be procedures you don’t understand. Do not attempt repairs if you do not understand the procedures.
- There are special tools and equipment that are required to perform some repairs. Do not attempt these repairs unless you have these special tools and/or equipment. You can cause damage to the product in excess of the cost a dealer would charge you.
- Also, if you partially disassemble an engine or drive assembly and are unable to repair it, the dealer’s mechanic must reassemble the components and test to determine the problem. This will cost you more than taking it to the dealer immediately upon having a problem. It may be a very simple adjustment to correct the problem.
- Do not telephone the dealer, service office or the factory to attempt for them to diagnose a problem or request the repair procedure. It is difficult for them to diagnose a problem over the telephone. A doctor can’t and won’t diagnose your illness by telephone; he must examine you personally, just as a mechanic must examine your power package.
- Your Authorized Dealer is there to service your power package. He has qualified factory-trained mechanics.

It is recommended you have the dealer do periodic maintenance checks on your power package. Have him winterize it in the fall and service it before the boating season. This will reduce the possibility of any problems occurring during your boating season when you want trouble-free boating pleasure.

20-Hour Break-In Period

IMPORTANT: The first 20 hours of operation is the engine break-in period. Correct break-in is essential to obtain minimum oil consumption and maximum engine performance. During this break-in period, the following rules must be observed:

- Do not operate below 1500 RPM for extended periods of time for first 10 hours. Shift into gear as soon as possible after starting and advance throttle above 1500 RPM **if conditions permit safe operation.**
- Do not operate at one speed consistently for extended periods.
- Do not exceed 3/4 throttle during first 10 hours. During next 10 hours, occasional operation at full throttle is permissible (5 minutes at a time maximum).
- Avoid full throttle acceleration from IDLE speed.
- Do not operate at full throttle until engine reaches normal operating temperature.
- Frequently check crankcase oil level. Add oil if needed. It is normal for oil consumption to be high during break-in period.
- After 20-hour break-in period, drain crankcase oil and replace oil filter (see MAINTENANCE). Fill crankcase with correct oil (see SPECIFICATIONS).

After Break-in Period

To help extend the life of your MerCruiser power package, the following recommendations should be considered;

- Use a propeller that allows the engine to operate at or near the top of the maximum RPM range (See “Specifications” section) when at full throttle with a normal boat load.
- Operation at 3/4 throttle setting or lower is recommended. Refrain from prolonged operation at maximum (full throttle) RPM.

20-Hour Checkup

After first 20 hours of operation, an Authorized MerCruiser Dealer should be contacted for the following maintenance. The boat owner is responsible for any charges.

- Change crankcase oil and filter.
- Hurth Transmissions, only - change filter.
- Check all fluid levels.
- Cooling System - Inspect all hoses for damage and deterioration; check all hose clamps for adequate tightness.
- Check carburetor adjustment.
- Inspect ignition system and timing.
- Check for loose, missing or damaged parts.
- Check shift and throttle cable adjustments - lubricate and inspect for loose, damaged or missing parts.
- Steering System - Lubricate and inspect for loose, damaged or missing parts.
- Inspect all drive belts.
- Check engine alignment.
- Complete Engine Exhaust System - Inspect for external damage and deterioration; check all hose clamps for adequate tightness.
- Change oil in Seawater/Fuel Pump (if Equipped). Use only Quicksilver High Performance Gear Lube to refill pump.

Operation

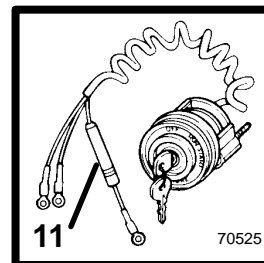
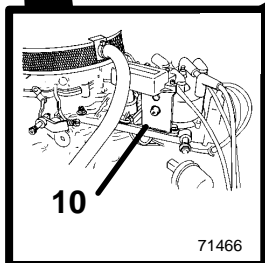
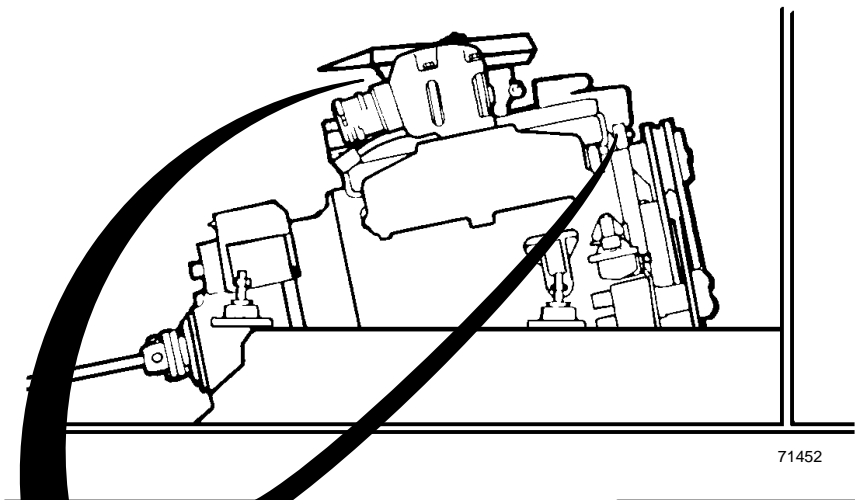
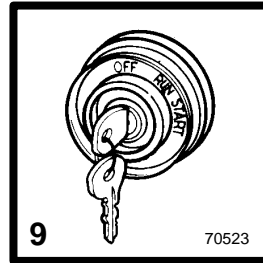
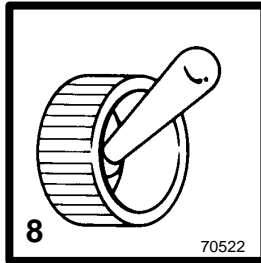
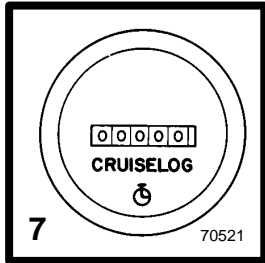
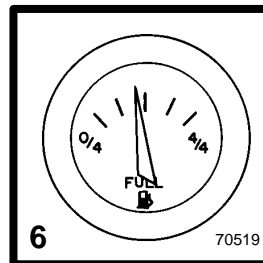
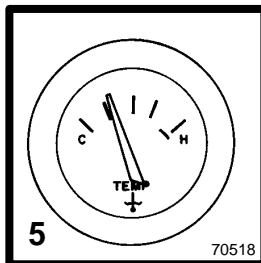
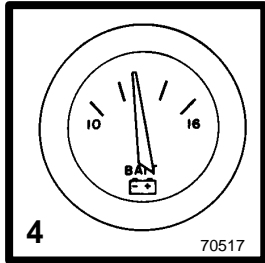
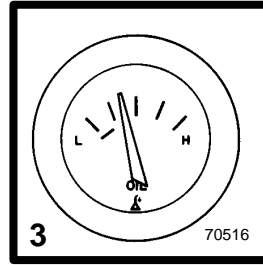
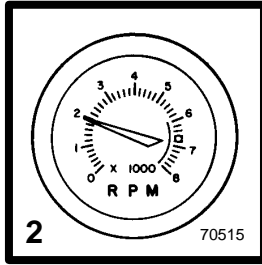
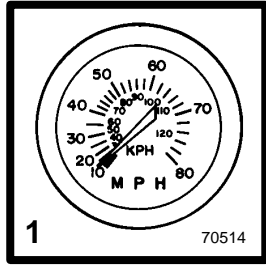

Instrumentation

The following is a brief explanation of instrumentation typically found on some boats. The owner/operator should be familiar with all instruments and their functions on the boat.

- 1 Speedometer - indicates boat speed.
- 2 Tachometer - indicates engine RPM.
- 3 Oil Pressure Gauge - indicates engine oil pressure.
- 4 Battery Meter - indicates battery voltage.
- 5 Water Temperature Gauge - indicates engine operating temperature.
- 6 Fuel Gauge - indicates fuel tank volume.
- 7 Hour Meter - records engine running time.
- 8 Bilge Blower Switch - must be operated for five minutes to ventilate bilge.
- 9 Ignition Switch - allows operator to start and stop engine.

Overload Protection Electrical System

If an electrical overload occurs, a fuse will blow or the circuit breaker will trip open. The cause must be found and corrected before replacing fuse or resetting circuit breaker.

10 A circuit breaker provides protection for engine wiring harness and instrumentation power lead. Reset by pushing RESET button IN.

In an emergency, when engine must be operated and cause for high current draw cannot be located and corrected, turn OFF or disconnect all accessories connected to engine and instrumentation wiring.

Reset circuit breaker. If breaker remains open, electrical overload has not been eliminated. Further checks must be made on electrical system.

11 A 20 amp fuse may be located in ignition switch "I" terminal lead to protect electrical system. Check for blown fuse if key is turned to START and nothing happens (and circuit breaker is not tripped).

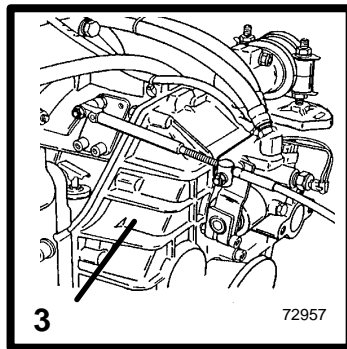
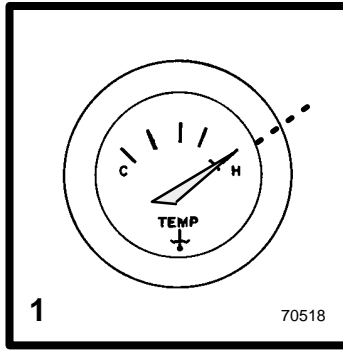
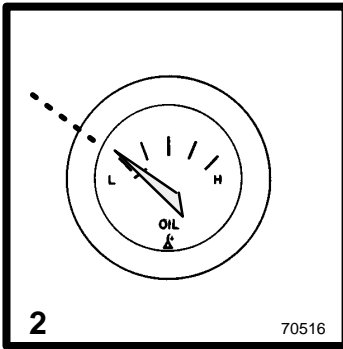

Audio Warning System

Warning buzzer will sound if:

- 1 Cooling system water temperature rises too high.
- 2 Engine oil pressure gets too low.
- 3 Transmission temperature is too high.

NOTE: To provide a test of the system, the audio warning buzzer will sound when the ignition switch is first turned to the run position, prior to cranking the engine. Once the engine starts, the buzzer should stop.

CAUTION

Avoid engine damage. Do not operate engine once the buzzer has sounded EXCEPT TO AVOID A HAZARDOUS SITUATION. The Audio Warning System will not protect the engine from damage. It is designed to warn the operator that a problem has occurred.

When the buzzer sounds with the engine running, stop engine immediately. Investigate cause and correct it, if possible. If cause cannot be determined, consult your Authorized MerCruiser Dealer.

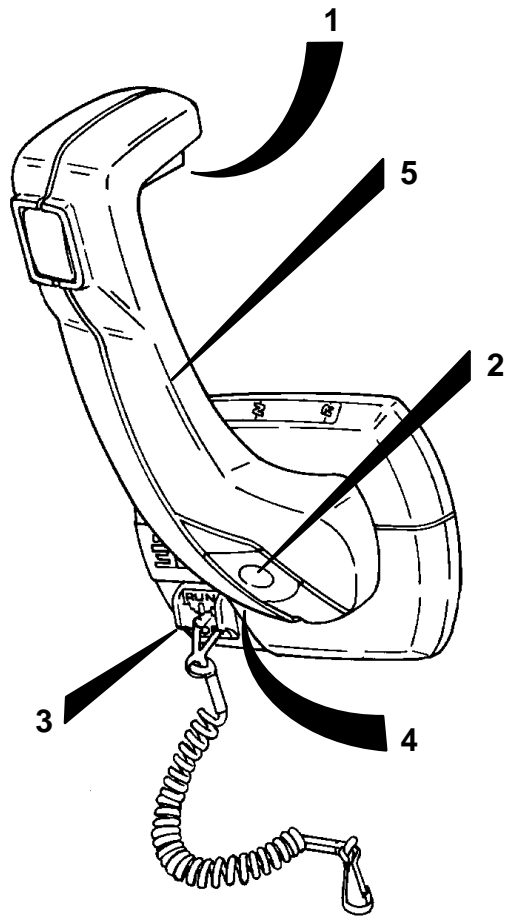

73866

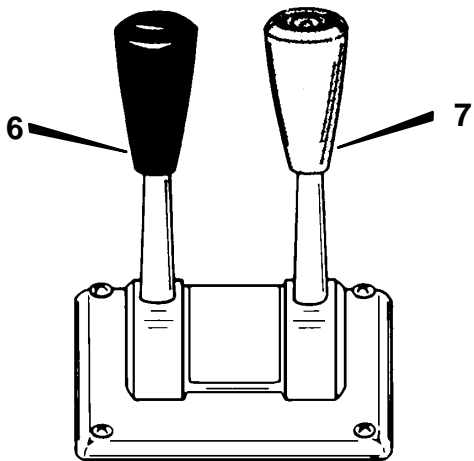

71339

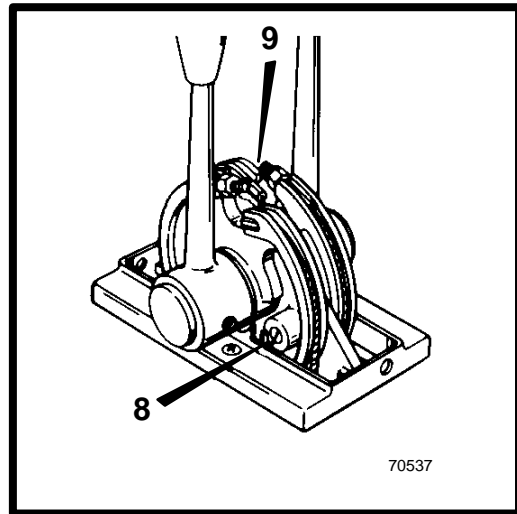

70537

Remote Controls (Panel Mounted)

Your boat may be equipped with one of many Quicksilver® remote controls available. All controls feature an integral safety switch that allows starting engine in NEUTRAL only. Also, all controls may not have all features shown.

NOTE: *If boat is equipped with a remote control other than shown, consult your dealer for a description and/or demonstration of the control.*

- 1 Neutral Lock Bar** - Prevents accidental shift and throttle engagement. Neutral lock bar must be pulled “Up” to move the control handle out of neutral.
- 2 Throttle Only Button** - Allows engine throttle advancement without shifting the engine. This is done by disengaging the shift mechanism from the control handle. The throttle only button can be depressed only when the remote control handle is in the “Neutral” position, and should only be used to assist in starting the engine.
- 3 Lanyard Stop Switch** - Turns ignition “Off” whenever the operator (when attached to the lanyard) moves far enough away from the operator’s position to activate the switch. See “Lanyard Stop Switch” at the front of this manual for safety warning on the use of this switch.
- 4 Control Handle Tension Adjustment Screw** - This screw can be adjusted to “Increase” or “Decrease” the tension on the control handle. This will help prevent “Creep” of the remote control handle. Turn screw “Clockwise” to increase tension and “Counterclockwise” to decrease tension. Adjust to tension desired.
- 5 Control Handle** - Operation of the shift and throttle are controlled by the movement of the control handle. “Push” the control handle forward from “Neutral” with a quick firm motion to the first detent for “Forward” gear. Continue pushing forward to increase speed. Pull the control handle back from “Neutral” with a quick firm motion to the first detent for “Reverse” gear. Continue pushing back to increase speed.

Remote Controls (Two Lever)

Your boat may be equipped with one of many Quicksilver® remote controls available. All controls feature an integral safety switch that allows starting engine in NEUTRAL only. Also, all controls may not have all features shown.

NOTE: *If boat is equipped with a remote control other than shown, consult your dealer for a description and/or demonstration of the control.*

- 6 Shift Lever** - shifts unit into gear with full lever movement. Move lever forward to shift to FORWARD gear. Move lever backward to shift to REVERSE gear. Lever in full vertical position shifts to NEUTRAL.

⚠ CAUTION

Never shift unit into or out of gear unless throttle lever is at idle RPM.

- 7 Throttle Lever** - allows engine RPM to be increased or decreased.
- 8 FRICTION Screw** - adjusts control handle friction so motor speed can be set and driver does not have to hold handle.
Turn screw clockwise to increase friction. Do not thread screw all the way out.
- 9 DETENT Screw** - controls the effort needed to move control handle out of NEUTRAL. To increase tension, turn screw clockwise; to decrease, turn screw counterclockwise. Do not thread screw all the way out.

IMPORTANT: Boats equipped with dual power packages may have both shift levers on one control and both throttle levers on the other control.

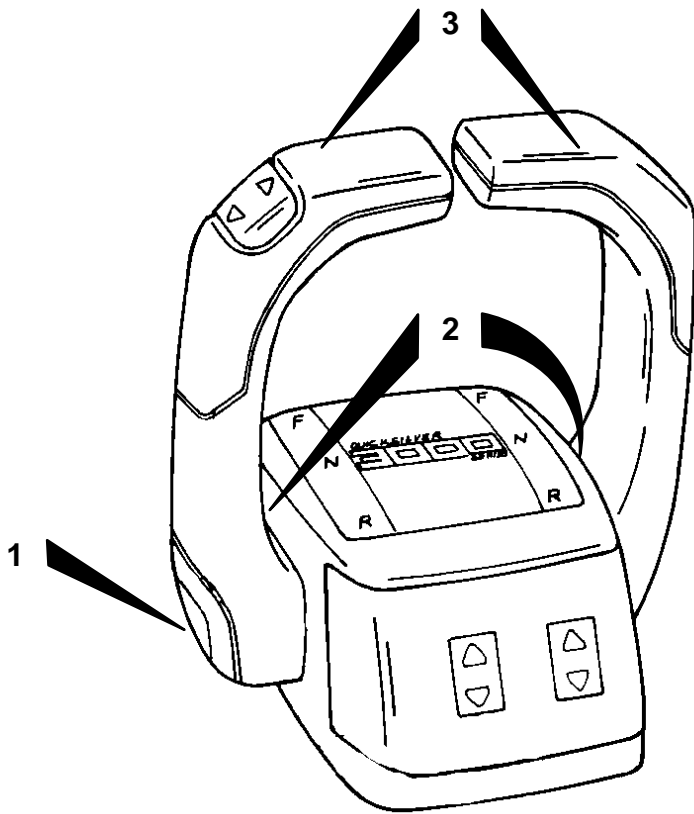
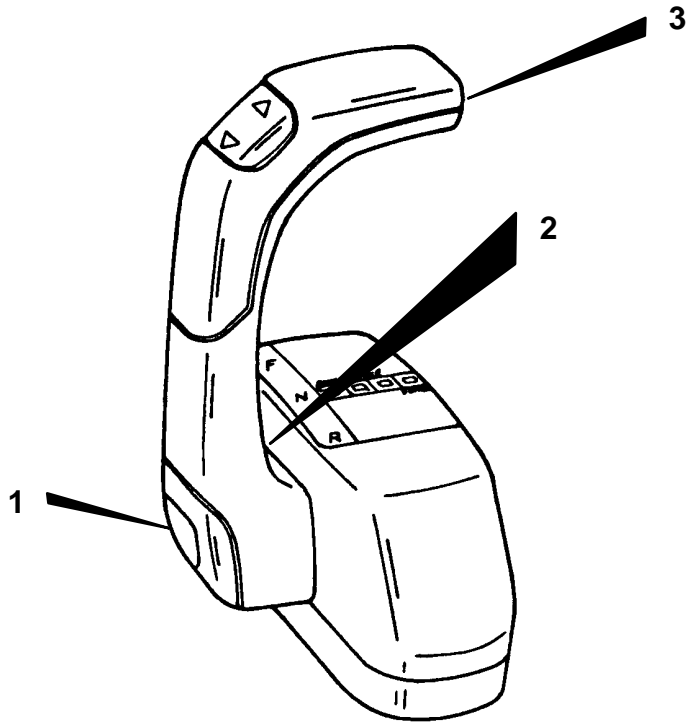

Remote Controls (Console Mounted)

Your boat may be equipped with one of many Quicksilver® remote controls available. All controls feature an integral safety switch that allows starting engine in NEUTRAL only. Also, all controls may not have all features shown.

NOTE: *If boat is equipped with a remote control other than shown, consult your dealer for a description and/or demonstration of the control.*

1 Throttle Only Button - Allows engine throttle advancement without shifting the engine. This is done by disengaging the shift mechanism from the control handle. The throttle only button can be depressed only when the remote control handle is in the "Neutral" position, and should only be used to assist in starting the engine.

2 Control Handle Tension Adjustment Screw - This screw can be adjusted to "Increase" or "Decrease" the tension on the control handle (cover must be removed to adjust). This will help prevent "Creep" of the remote control handle. Turn screw "Clockwise" to increase tension and "Counterclockwise" to decrease tension. Adjust to tension desired.

3 Control Handle(s) - Operation of the the shift and throttle are controlled by the movement of the control handle. "Push" the control handle forward from "Neutral" with a quick firm motion to the first detent for "Forward" gear. Continue pushing forward to increase speed. Pull the control handle back from "Neutral" with a quick firm motion to the first detent for "Reverse" gear. Continue pushing back to increase speed.

Starting, Shifting and Stopping

WARNING

Before starting engine, operate bilge blower for at least five minutes to remove any explosive fumes from engine compartment. If boat is not equipped with a bilge blower, open engine hatch and leave open while starting engine.

IMPORTANT: Observe the following:

- Do not start engine without water being supplied to seawater pickup pump (to prevent pump or engine damage).
- Do not operate starter motor continuously for more than 30 seconds.
- When engine starts, quickly reduce throttle setting to avoid exceeding 1500 RPM.
- Never shift unit unless engine is at idle RPM.

A Check all items listed in OPERATION CHART.

B Perform any other necessary checks, as indicated by your dealer, or specified in your boat owner's manual.

C Place control handle in NEUTRAL.

D Position throttle setting as follows:

COLD ENGINE - Move control/throttle lever to full throttle, then return to about 1/4 throttle. In extreme cold it may be necessary to pump lever more than once.

WARM ENGINE - Move control/throttle lever to 1/4 throttle position.

FLOODED ENGINE - Move control/throttle lever to full throttle. Be prepared to decrease engine speed to 1000-1500 RPM as soon as engine starts.

E Turn ignition key to START. Release key when engine starts and allow switch to return to RUN position. Move control/throttle lever back to decrease engine RPM to 1000-1500 RPM if necessary.

F Check oil pressure gauge immediately after engine starts. If oil pressure is not within specified range (see SPECIFICATIONS), stop engine immediately and determine cause.

G If engine is cold, run engine for 1 or 2 minutes at fast idle (1000-1500 RPM).

H After engine has warmed up, check water temperature gauge to ensure that engine temperature is not abnormally high. If it is, stop engine immediately and determine cause.

I Be sure charging system is functioning correctly.

J Observe power package for fuel, oil, water and exhaust leaks.

K To shift unit, return control/throttle lever to NEUTRAL. Move control/shift lever with a firm, quick motion forward to shift to FORWARD gear, or backward to shift to REVERSE. After shifting drive unit, advance throttle to desired setting.

L Move control/shift lever to NEUTRAL and allow engine to drop to IDLE speed. If engine has been run at high speed for a long period of time, allow engine to cool by running at IDLE speed for 3 to 5 minutes.

M Turn ignition key to OFF.

Operation Chart

BEFORE STARTING	AFTER STARTING	WHILE UNDERWAY	AFTER STOPPING
Open engine hatch.	Observe all gauges to check condition of engine. If not normal, stop engine.	Observe all gauges to monitor engine condition. If not normal, stop engine.	Turn ignition key OFF.
Check engine oil level (8.2L only)	Check for fuel, oil, water, fluid and exhaust leaks, etc.		Turn battery switch OFF, if so equipped.
Turn battery switch ON, if so equipped.	Check shift and throttle control operation.		Close fuel valve, if so equipped
Operate bilge blowers, if so equipped.	Check steering operation		Close seacock, if so equipped.
Open fuel shut-off valve.			Flush cooling system, if in a saltwater area.
Open seacock, if so equipped.			
Perform all other checks specified by your dealer and/or boat builder.			

Specifications

Fuel Recommendations

IMPORTANT: Use of improper gasoline can damage your engine seriously. Engine damage resulting from use of improper gasoline is considered misuse of engine, and damage caused thereby will not be covered under the limited warranty.

FUEL RATINGS

MerCruiser engines will operate satisfactorily when using a major brand of unleaded gasoline as follows:

USA and Canada - having a posted pump Octane Rating of 87 (R+M)/2 minimum. Premium gasoline [92 (R+M)/2 Octane] is also acceptable. DO NOT use leaded gasoline.

Outside USA and Canada - having a posted pump Octane Rating of 90 RON minimum. Premium gasoline (98 RON) is also acceptable. If unleaded gasoline is not available, use a major brand of leaded gasoline.

CA291

Using Reformulated (Oxygenated) Gasolines (USA Only)

This type of gasoline is required in certain areas of the USA. The two types of “oxygenates” used in these fuels is Alcohol (Ethanol) or Ether (MTBE or ETBE). If Ethanol is the “oxygenate” that is used in the gasoline in your area, refer to “Gasolines Containing Alcohol” also.

These “Reformulated Gasolines” are acceptable for use in your MerCruiser engine.

CA277

Gasolines Containing Alcohol

If the gasoline in your area contains either “methanol” (methyl alcohol) or “ethanol” (ethyl alcohol), you should be aware of certain adverse effects that can occur. These adverse effects are more severe with “methanol”. Increasing the percentage of alcohol in the fuel can also worsen these adverse effects.

Some of these adverse effects are caused because the alcohol in the gasoline can absorb moisture from the air, resulting in a separation of the water/alcohol from the gasoline in the fuel tank.

The fuel system components on your MerCruiser engine will withstand up to 10% alcohol content in the gasoline. We do not know what percentage your boat’s fuel system will withstand. Contact your boat manufacturer for specific recommendations on the boat’s fuel system components (fuel tanks, fuel lines, and fittings). Be aware that gasolines containing alcohol may cause increased:

- Corrosion of metal parts.
- Deterioration of rubber or plastic parts.
- Fuel permeation through rubber fuel lines.
- Starting and operating difficulties.

WARNING

FIRE AND EXPLOSION HAZARD: Fuel leakage from any part of fuel system can be a fire and explosion hazard which can cause serious bodily injury or death. Careful periodic inspection of entire fuel system is mandatory, particularly after storage. All fuel components including fuel tanks, whether plastic metal or fiberglass, fuel lines, fittings, fuel filters and carburetors/fuel injection components should be inspected for leakage, softening, hardening, swelling or corrosion. Any sign of leakage or deterioration requires replacement before further engine operation.

Because of possible adverse effects of alcohol in gasoline, it is recommended that only alcohol-free gasoline be used where possible. If only fuel containing alcohol is available, or if the presence of alcohol is unknown, increased inspection frequency for leaks and abnormalities is required.

IMPORTANT: When operating a MerCruiser engine on gasoline containing alcohol, storage of gasoline in the fuel tank for long periods should be avoided. Long periods of storage, common to boats, create unique problems. In cars alcohol-blend fuels normally are consumed before they can absorb enough moisture to cause trouble, but boats often sit idle long enough for phase separation to take place. In addition, internal corrosion may take place during storage if alcohol has washed protective oil films from internal components.

Quicksilver Gasoline Stabilizer for Marine Engines (92-817529A12) is highly recommended for addition during storage periods. See “Cold Weather or Extended Storage” later in this manual.

CC218
SEACOCK SIZE RECOMMENDATION

Seacock used, must have an internal cross-sectional area equal to or greater than hose to prevent restricting waterflow. Install valve in an area where it will be easily accessible and supported adequately to prevent hose fatigue. A 1-1/4 in. (32mm) brass ball or gate valve is suggested.

CC16
SEA STRAINER RECOMMENDATION

Strainer used must be of sufficient size to ensure that an adequate supply of water will be maintained for cooling engine. A minimum of 30 gallons per minute (114 litres per minute) flow rate, is required.

CC18
CRANKCASE OIL

To help obtain optimum engine performance and to provide maximum protection, we strongly recommend the use of Quicksilver 4-Cycle Marine Engine Oil. If not available, a good grade, straight weight, detergent automotive oil of correct viscosity, with an API classification of SG/CD II, may be used.

The chart below is a guide to crankcase oil selection. Oil filter should always be changed with oil.

In those areas where recommended straight weight oil is not available, a multi-viscosity 20W-40 (SG/CD 11) or, as a second but less preferable choice, 20W-50 (SG/CD II) may be used.

IMPORTANT: The use of non-detergent oils, multiviscosity oils (other than 20W-40 or 20W-50), low quality oils or oils which contain solid additives specifically are not recommended.

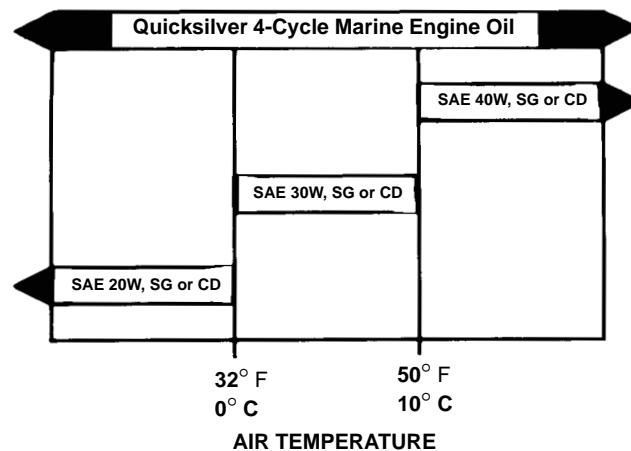

70534

Engine

DESCRIPTION	SPECIFICATION - MIE (Inboard)		
	5.7L	7.4L	8.2L
Propshaft Horsepower (BSO/SAV Rating)	260 ¹ (220 ²)	310 ¹	400 ¹
Propshaft Kilowatts (BSO/SAV Rating)	193 ¹ (164 ²)	231 ¹	298 ¹
Displacement	350 cu. in. (5.7 L)	454 cu. in. (7.4 L)	502 cu. in. (8.2 L)
Engine Type	V-8		
Bore	4.00 in. (101.6mm)	4.25 in. (108mm)	4.47 in. (113.5mm)
Stroke	3.48 in. (88.39mm)	4.00 in. (101.6mm)	
Compression Ratio	9.1:1	8.5:1	8.75:1
Compression Pressure	150 PSI (1035 kPa)		
Maximum RPM @ WOT	4000-4400		4400-4800
Idle RPM in Neutral Gear ³	650 RPM ⁴		
Oil Pressure:	@ 2000 RPM	30-60 PSI (207-414 kPa)	30-70 PSI (207-483 kPa)
	Min. @ Idle	3.7 PSI (28 kPa)	
Thermostat	160° F (71° C)		

¹ Power Rated in Accordance with NMMA (National Marine Manufacturers' Association) rating procedures.

² Power Rated in Accordance with BSO/SAV rating procedures. This rating procedure is used to certify that the engine complies with "Stage 1" Bodensee and Swiss Regulations. Horsepower differences shown result from differences in test RPM and allowable test tolerances.

³ Measured using an accurate service tachometer.

⁴ A special procedure must be followed for adjusting idle RPM in Forward Gear. Consult your Authorized MerCruiser Dealer before adjusting idle speed.

Tune-Up

DESCRIPTION	SPECIFICATION - MIE (Inboard)		
	5.7L	7.4L	8.2L
Spark Plug Type	AC-MR43T, Champion RV15YC4, or BR6FS		
Spark Plug Gap	.035 in. (.9mm)		
Timing @ Idle RPM ¹	10° BTDC ²		
Idle Mixture Screw Preliminary Setting	1-1/4 Turns		
Firing Order (LH Rotation)	1-8-4-3-6-5-7-2		
Electrical System	12-volt Negative (-) Ground		
Alternator Rating	55 Amps		
Recommended Battery Rating	375 cca, 475 mca or 90 Ah	450 cca, 575 mca, or 90 Ah	

¹ In addition to timing marks on front of engine, some models have timing window location in top of flywheel housing.

² A special procedure must be followed to check or adjust Timing. Consult your Authorized MerCruiser Dealer before attempting this procedure.

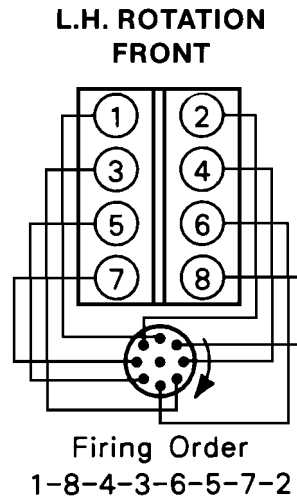

71412

Capacities

NOTE: All capacities are given in approximate U. S. Quarts (Liters).

DESCRIPTION			SPECIFICATION - MIE (Inboard)		
			5.7L	7.4L	8.2L
Crankcase Oil Capacity with New Filter ¹			5 (4-3/4)	7 (6-2/3)	
Seawater Cooling System ²			15 (14)	20 (19)	
Closed Cooling System ²			20 (19)	28 (26-1/2)	
Transmission ¹	Velvet Drive	71C, Direct Drive In-Line -1:1	2 (2)		
		72C, Direct Drive In-Line -1:1		2 (2)	
		5000A - 8° Down Angle	2-1/2 (2-1/3)		
		5000V - V-Drive	5 (4-3/4)		
	Hurth	630A - 8° Down Angle	4-1/4 (4)		
		800A - 8° Down Angle		4-1/2 (4.25)	
		630V - V-Drive	5 (4-3/4)		

¹ Always use dipstick to determine exact quantity of oil required.

² Seawater Cooling System capacity information is for winterization use only.

Maintenance

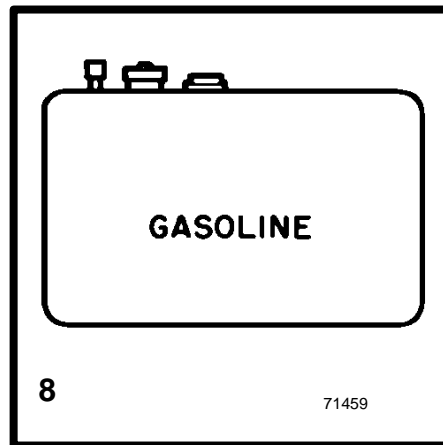
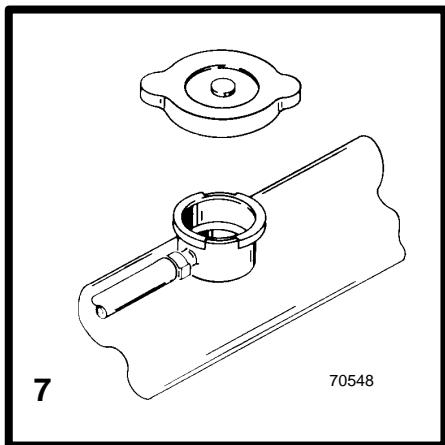
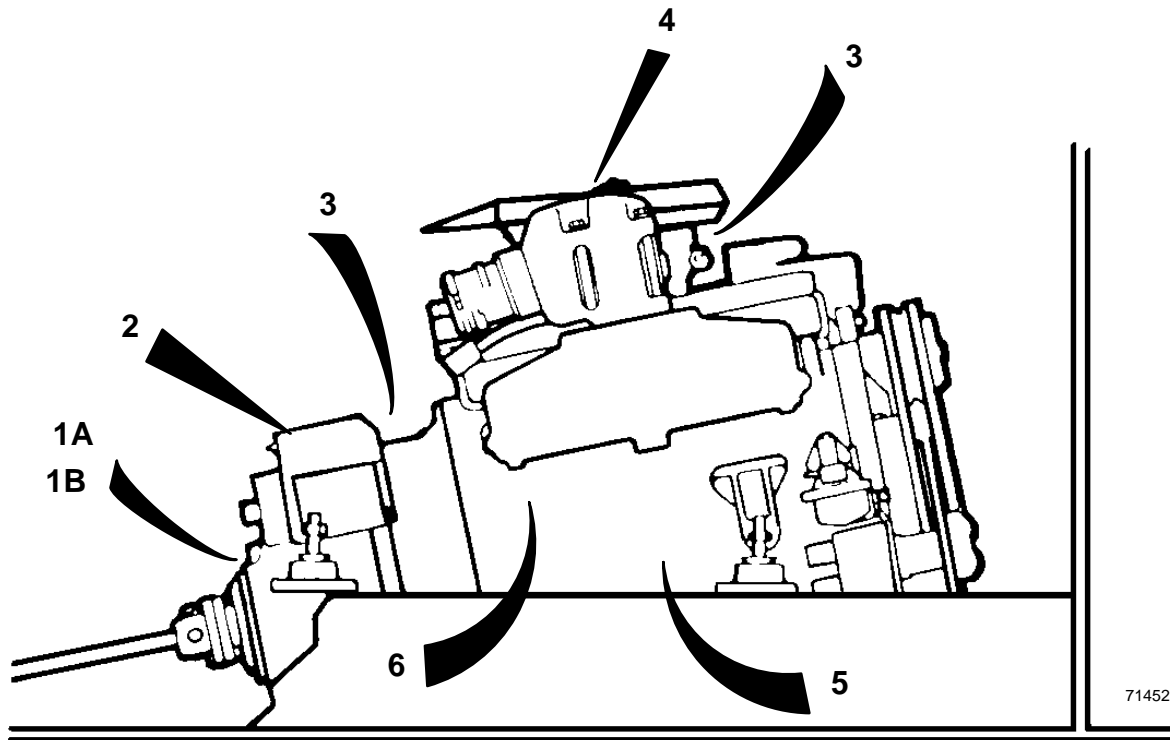

Maintenance Products

WARNING

Always disconnect battery cables from battery before working around electrical system components to prevent injury to yourself or damage to electrical system.

IMPORTANT: Refer to MAINTENANCE CHART for complete listing of all scheduled maintenance to be performed. Some listings can be done by owner/operator, while others should be performed by an Authorized MerCruiser Dealer. Before attempting maintenance or repair procedures not covered in this manual, it is recommended that a MerCruiser Service Manual(s) be purchased and read thoroughly.

1 Transmission Fluid:

CAUTION

Avoid damage to transmission. The transmission on your MerCruiser product is filled with Dexron III transmission fluid at the factory. Do not mix other transmission fluids with Dexron III transmission fluid.

- A** Velvet Drive In-Line - Dexron III Automatic Transmission Fluid or 10 wt. tractor hydraulic fluid meeting the C-3/TO-2 specification. (Preferably Mobil 424, Chevron, or Citgo.)
- B** Hurth Transmissions, Velvet Drive 5000 Series (Down-Angle and V-Drive) Transmissions - ATF Dexron III.
- 2** Starter Motor - SAE 30W motor oil.
- 3** All Pivot Points - SAE 30W motor oil.
- 4** Fogging (Winterizing) Engine - Quicksilver Storage Seal or SAE 20W motor oil.
- 5** Crankcase Oil - Quicksilver 4-Cycle Marine Engine Oil. (Refer to SPECIFICATIONS for alternatives and oil recommendations for varying ambient temperatures.)
- 6** All Exterior Surfaces - Quicksilver Primer and Spray Paint and Quicksilver Corrosion Guard.
- 7** Closed Cooling System Coolant - MerCruiser recommends the use of Quicksilver Premixed Marine Engine Coolant (a special low silicate, ethylene glycol antifreeze with special additives, and purified water), if this is not available use a 50/50 mixture of ethylene glycol antifreeze (must meet GM specification 1825 M) and tap water. Areas where temperatures generally do not go below 32° F (0° C), rust inhibitor and tap water is acceptable.
- 8** Gasoline Stabilizer - Quicksilver Gasoline Stabilizer for Marine Engines.

Maintenance Chart

⚠ WARNING

Always disconnect battery cables from battery BEFORE working around electrical system components to prevent injury to yourself or damage to electrical system should a wire be accidentally shorted.

Only perform maintenance which applies to your particular power package.

SCHEDULED MAINTENANCE TO BE PERFORMED BY OWNER / OPERATOR

TASK	INTERVAL
Seawater Strainer - Check and clean	Before Use and Whenever Insufficient Seawater Flow is Suspected (If Operating Temperature Exceeds Normal Range)
Water Pickups - Check for marine growth or debris.	
Engine Crankcase Oil - Check level (See NOTE 1.)	Weekly
Transmission Fluid - Check level.	
Closed Cooling System Coolant - Check level	
Battery - Check level and inspect for damage	
Fuel Pump Sight Tube - Check for no fuel present	
Drive Belts - inspect condition and check tensions.	Every 100 Hours of Use or 120 Days - Whichever Occurs First. Once a Year.
Power Package Exterior Surfaces - spray with Quicksilver Corrosion Guard.	Saltwater use: Every 50 hours of operation or 60 days, Whichever Occurs First Freshwater use: Every 100 hours of operation or 120 days, Whichever Occurs First
Power Package Exterior Surfaces - clean and paint.	Once a Year
Cooling System - flush seawater section.	Saltwater Use: After Each Use

NOTE 1. : MIE 8.2L Models - Check every 3 hours of operation.

Maintenance Chart

Only perform maintenance which applies to your particular power package.

SCHEDULED MAINTENANCE TO BE PERFORMED BY DEALER

TASK	INTERVAL
20 - Hour Checkup (See NOTE 1)	At First 20 Hours of Operation
Seawater Pickup Pump - Disassemble and Inspect	Whenever Insufficient Seawater Flow is Suspected. (If Operating Temperature Exceeds Normal Range)
Transmission Fluid - Change	After first 20 hours, then every 100 hours of operation thereafter
Transmission Filter (Hurth Models) - Change	
Crankcase Oil and Oil Filter - change	Every 100 Hours of Operation or Once Yearly, Whichever Occurs First
Ignition System - clean and inspect condition.	
Flame Arrestor and Crankcase Ventilation Hose - clean and inspect.	
Replace Positive Crankcase Valve (PCV)	
Engine Alignment - check.	
Electrical system - Check for loose or damaged wiring.	Saltwater use: Every 50 hours of operation or 60 days, Whichever Occurs First. Freshwater use: Every 100 hours of operation or 120 days, Whichever Occurs First.
Cooling system hoses and clamps - Inspect for damage and deterioration. Check clamps for tightness.	
Engine Exhaust System - Inspect for external damage, deterioration and restrictions. Check clamps for tightness.	
Shift and Throttle Cable and Linkage - Lubricate and inspect for loose, damaged or missing parts.	
Ignition System - check timing; adjust if needed	Once a Year
Fuel Filters - replace.	
Steering Head and Remote Control - inspect and lubricate.	
Closed Cooling Coolant - test for alkalinity	
Heat Exchanger - clean seawater section.	
Carburetor - inspect and adjust.	Every 2 Years
Closed Cooling Coolant - replace.	

NOTE 1 : For a list of 20-Hour Checkup maintenance items to be performed, see "IMPORTANT INFORMATION" section of this manual.

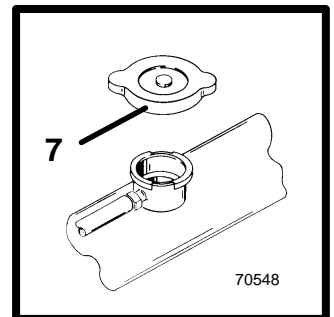
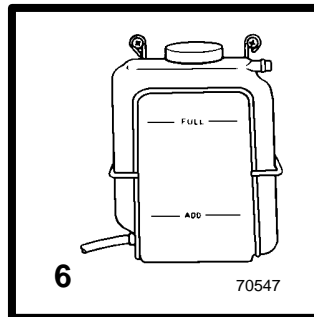
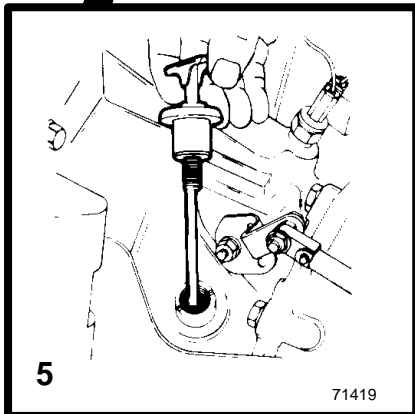
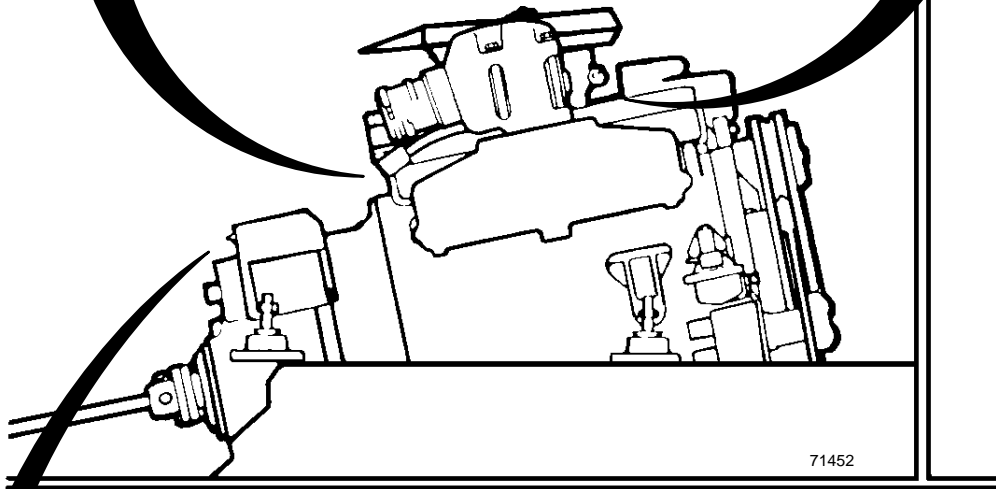
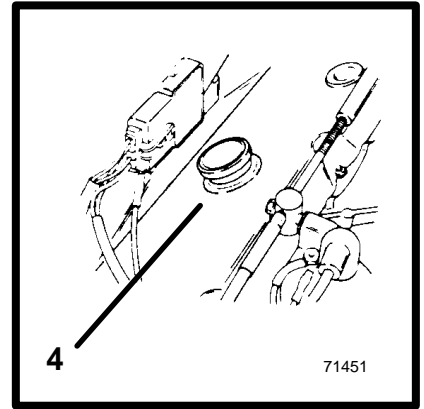
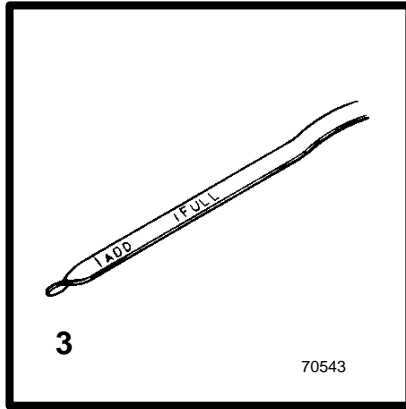
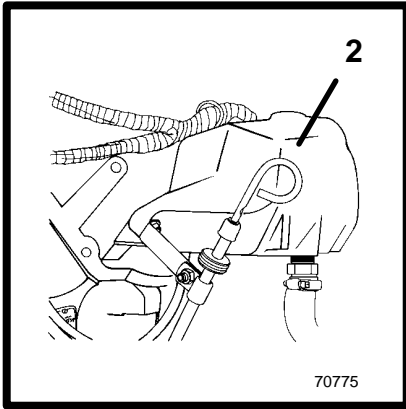

Checking Fluid Levels

CHECKING CRANKCASE OIL

8.2L Bluewater Inboard: ENGINE CRANKCASE OIL MUST BE CHECKED AT INTERVALS SPECIFIED IN “MAINTENANCE CHART.” It is normal for an engine to use a certain amount of oil in the process of lubricating and cooling the engine. Oil consumption will be higher on the 8.2L Bluewater Inboard. This engine uses forged (rather than cast) aluminum pistons to withstand the higher stresses created by its higher horsepower output. The forged pistons require increased piston-to-cylinder bore clearance to accommodate their higher thermo-expansion rate and thus, it is normal for some oil to get past the piston rings and be burnt-up in the combustion chambers. The amount of oil consumption is greatly dependant upon engine speed, with consumption being highest at wide-open-throttle and decreasing substantially as engine speed is reduced.

It is not uncommon for big block high performance engines to use up to 1 quart of oil in 1-5 hours if the engine is operated continuously at the upper end of the RPM range.

- 1 Stop engine. Allow approximately five minutes for oil to drain into oil pan. Boat must be at rest in water.
- 2 Remove dipstick. Wipe clean and reinstall fully into dipstick tube.
- 3 Remove dipstick and observe oil level. Oil level must be between FULL and ADD. If oil level is below ADD:
- 4 Remove oil filler cap. Add specified oil to bring level up to, but not over, “FULL” mark on dipstick.

IMPORTANT: Do not overfill crankcase oil.

CHECKING TRANSMISSION FLUID

IMPORTANT: Engine must be run at 1500 RPM for 2 minutes immediately prior to checking level.

- 5 Check transmission fluid using the appropriate procedure for the model of transmission on your engine:
 - A Velvet Drive Transmissions – Stop engine and quickly (before fluid drains back into transmission from cooler and lines) check fluid level by turning handle counterclockwise, to remove dipstick. Fluid level should be up to full mark. If low, add specified fluid through dipstick tube on Velvet Drive transmissions.
 - B Hurth Transmissions – Stop engine and check transmission fluid level, using dipstick. If fluid is below top (full) line, add specified fluid, through dipstick hole, to bring level up to top line. Do not overfill. Reinstall dipstick with cap fully seated.

IMPORTANT: DO NOT allow fluid level to drop below the bottom line.

CHECKING ENGINE COOLANT - CLOSED COOLING MODELS ONLY

- 6 Check coolant level in coolant recovery bottle. Add specified coolant as required.

⚠ WARNING

Do not remove coolant cap when engine is hot. Coolant may discharge violently and cause severe burns. Allow engine to “cool down” before attempting to remove cap.

- 7 Periodically remove cap from coolant reservoir to ensure that coolant recovery system is functioning properly. Coolant level must be at top of reservoir fill neck. If coolant is low, inspect gasket in cap for damage and replace if necessary. To have cap tested, contact your Authorized MerCruiser Dealer. Inspect coolant recovery system for leaks.

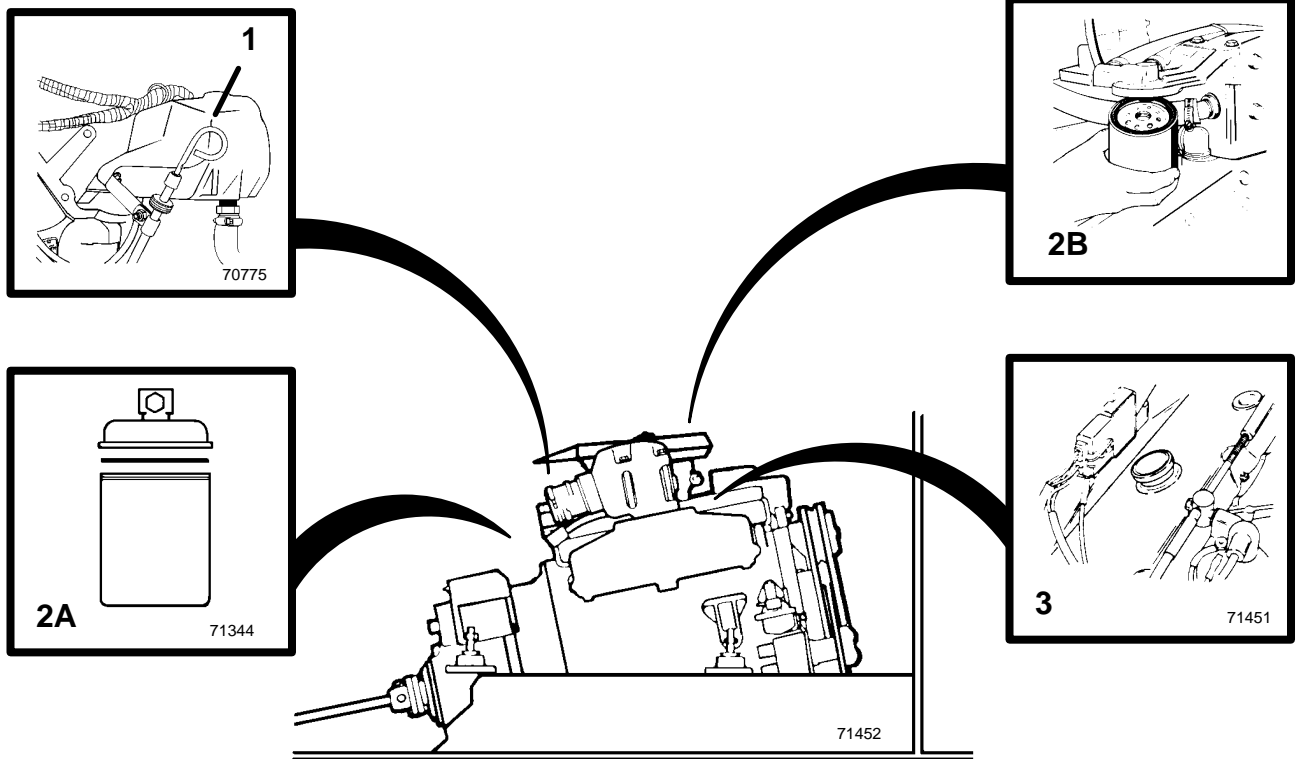

Changing Fluids

See MAINTENANCE CHART for lubricant change frequency. Lubricant should be changed before placing boat in storage.

Transmission fluid and coolant in closed cooling system should be changed at specified intervals by your Authorized MerCruiser Dealer.

CHANGING CRANKCASE OIL AND FILTER

IMPORTANT: Change oil when engine is warm from operation. Warm oil flows more freely, carrying away more impurities. Use only recommended motor oil (see SPECIFICATIONS).

1 With engine at normal operating temperature, remove dipstick. Install Quicksilver Crankcase Oil Pump onto dipstick tube.

Insert hose end of crankcase oil pump into an appropriate container and, using pump handle, pump until crankcase is empty. Remove crankcase oil pump.

2 Turn oil filter counterclockwise (to left); remove and discard old oil filter and old sealing ring. Coat sealing ring on new filter with motor oil. Install new sealing ring and filter by turning clockwise (to right). Tighten filter securely. Do not overtighten.

A Models Without Remote Oil Filter

B Models With Remote Oil Filter

3 Remove oil filler cap. Add correct type oil (see SPECIFICATIONS) to bring level up to, but not over FULL mark on dipstick.

IMPORTANT: Always use dipstick to determine exactly how much oil is required.

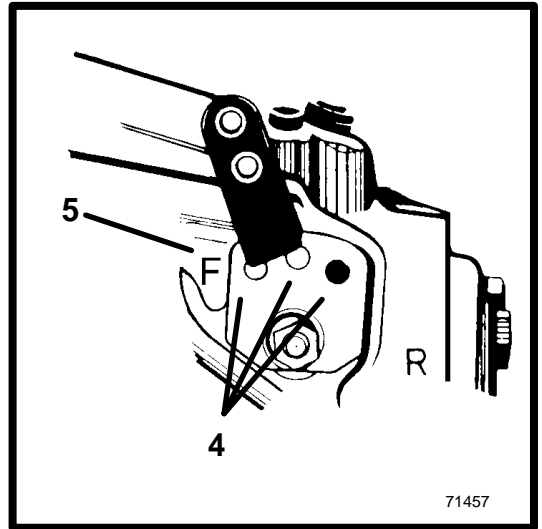
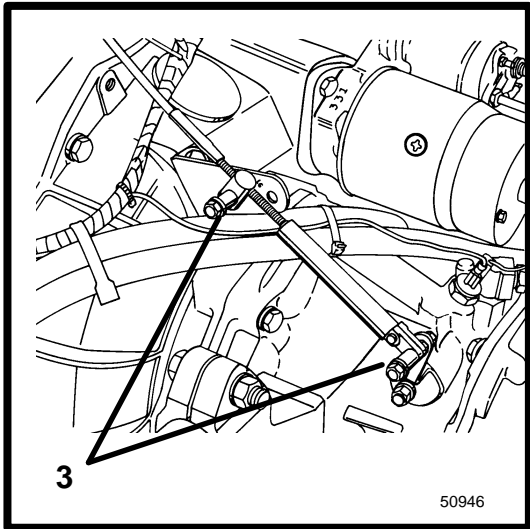
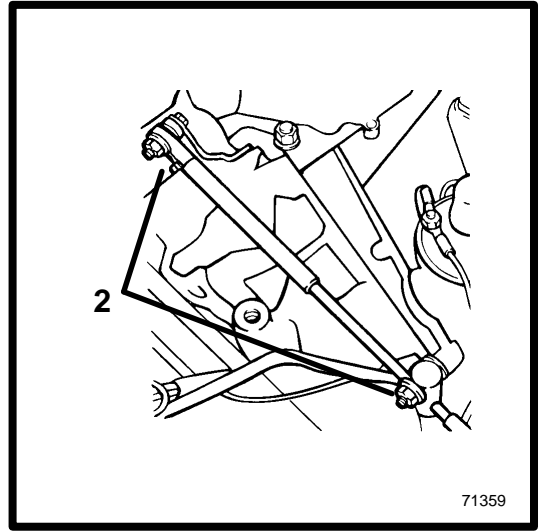
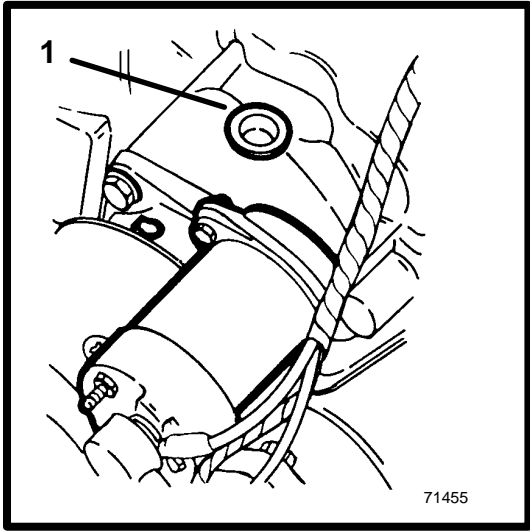

Lubrication

STARTER MOTOR

- 1 Lubricate with specified motor oil.

THROTTLE CABLE

- 2 Lubricate pivot points with specified motor oil.

SHIFT CABLE

- 3 Velvet Drive 5000 Series Transmissions or Hurth Transmissions - lubricate pivot points with specified motor oil.
- 4 Velvet Drive In-Line Transmissions, only - lubricate poppet ball and holes in lever with specified motor oil.

IMPORTANT: Poppet Ball MUST BE centered in detent hole for each F-N-R position on the Velvet Drive In-Line Transmissions, only.

- 5 Velvet Drive In-Line Transmissions, only - shift lever must be over this letter ("F") when propelling boat FORWARD.

IMPORTANT: Remote control, shift cable and linkages, must position transmission shift lever so that it is fully in the forward and reverse gear detent positions with the lever over the letter "F" on transmission case when propelling boat forward (There are no letters "F or R" on Velvet Drive 5000 Series Transmissions). IMPROPER POSITIONING OF SHIFT LEVER MAY CAUSE TRANSMISSION TO FAIL. Damage caused to transmission as a result of improper shift lever positioning will not be covered by Velvet Drive Transmission Warranty.

To obtain service and/or parts literature for your Velvet Drive transmission, contact:

Velvet Drive
 Marine and Industrial Transmissions
 Theodore Rice Boulevard
 Industrial Park
 New Bedford, MA 02745 U.S.A.

To obtain service and/or parts literature for Hurth transmissions, refer to "Owner's Service Assistance and Warranty Information Section."

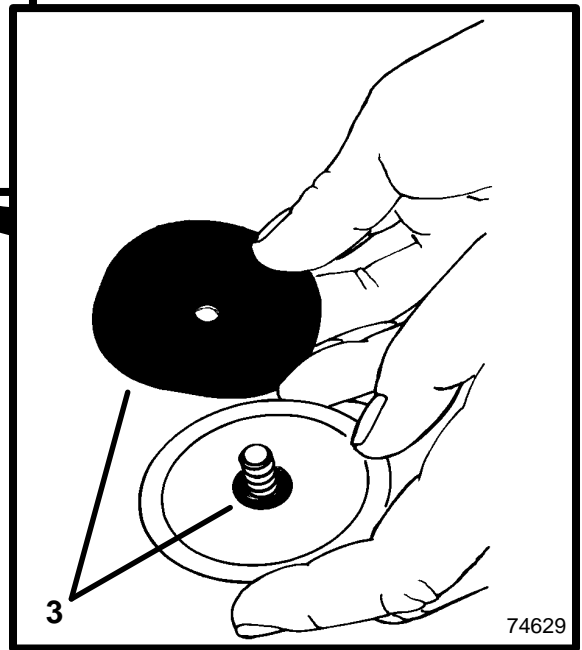
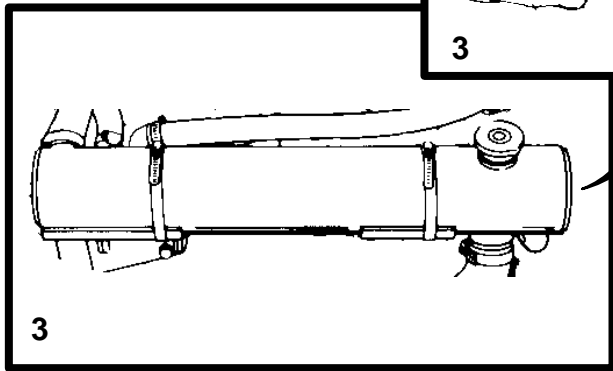
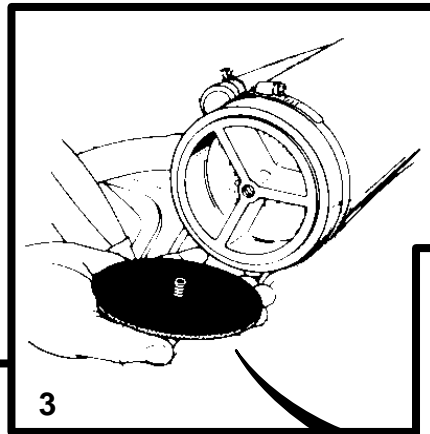
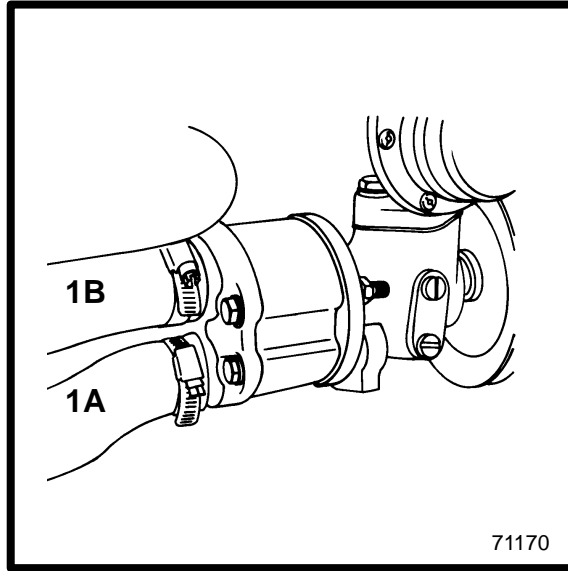

Flushing Cooling System

⚠ WARNING

When flushing, be certain the area around propeller is clear, and no one is standing nearby. To avoid possible injury, remove propeller.

⚠ CAUTION

Do not run engine above 1500 RPM when flushing. Suction created by seawater pickup pump may collapse flushing hose, causing engine to overheat. Watch temperature gauge on dash to ensure that engine does not overheat.

⚠ CAUTION

If cooling system is to be flushed with boat in the water, water inlet valve (if so equipped) must be closed, or water inlet hose must be disconnected and plugged to prevent water from flowing into boat. If boat is in the water, do not open water inlet valve until engine is to be restarted, to prevent contaminated water from flowing back into engine.

To prevent silt and/or salt buildup in cooling system, flush with freshwater at specified intervals.

1 Disconnect water inlet hose from aft end of seawater pickup pump.

A Models with Seawater Pump Only - Remove lower hose.

B Models with Seawater/Fuel Pump (Combination) - Remove upper hose.

2 Using appropriate connector, connect hose between connector and water tap. Partially open water tap (about 1/2 maximum). Place remote control in NEUTRAL, idle speed position and start engine. Operate engine at idle speed, in NEUTRAL, for about 10 minutes, or until discharge water is clear. Stop engine. Shut off water, remove flushing connector from pump inlet and reconnect water inlet hose. Tighten hose clamp securely.

Cleaning Seawater Section Of Heat Exchanger - Closed Cooled Models Only

Seawater section of heat exchanger (and oil cooler on 8.2L model) should be cleaned at least once a year or whenever decreased cooling efficiency is noticed.

3 Remove bolts securing end plates to each end of heat exchanger. Remove end plates, sealing washers and gaskets. Discard sealing washers and gaskets and clean gasket material from end plates and heat exchanger (and oil cooler if so equipped).

Clean water passages by inserting a wire brush into each passage. Use compressed air to blow loose particles out. Apply Quicksilver Perfect Seal to both sides of new end plate gaskets. Assemble new gaskets, new sealing washers and end plates onto heat exchanger (and oil cooler if so equipped). Install bolts and tighten securely. Start engine and inspect cooling system for leaks.

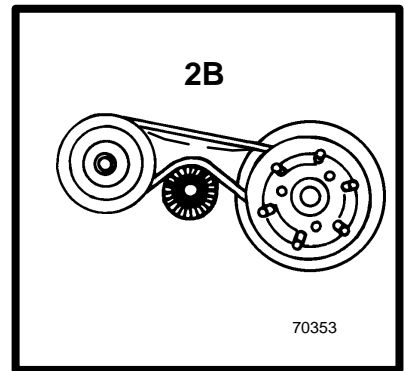
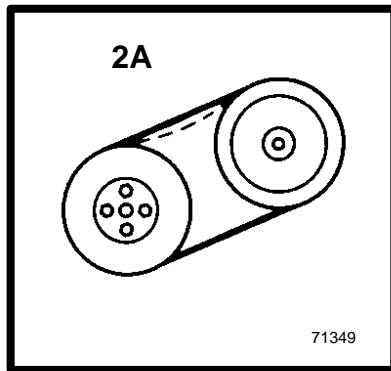
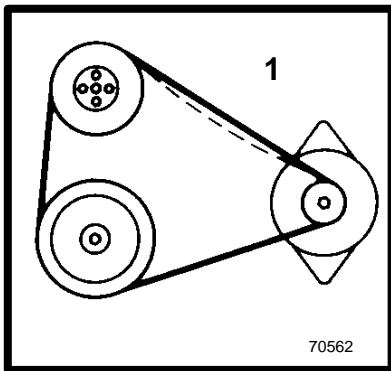
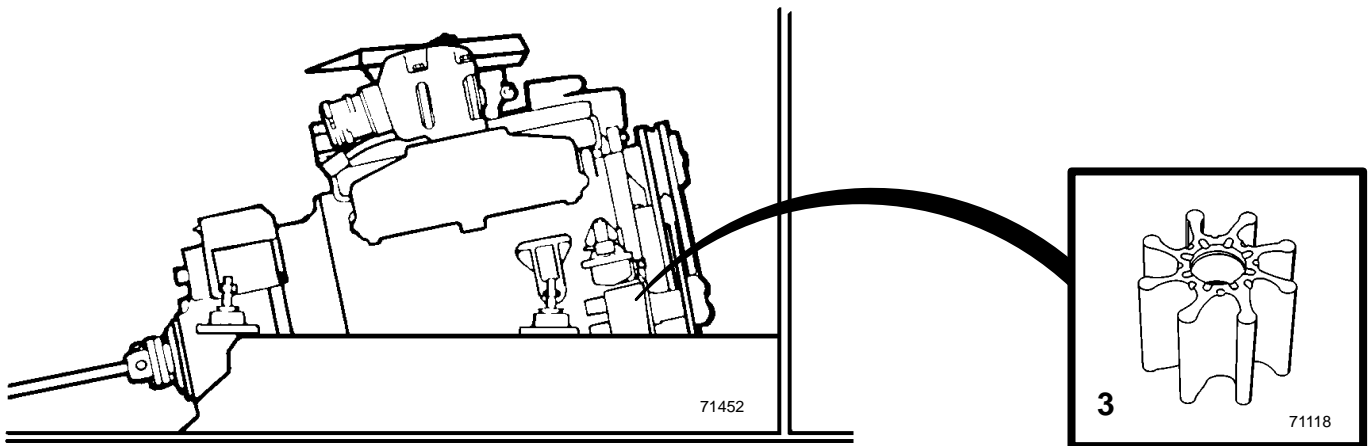

Drive Belts

WARNING

Avoid injury caused by hands or clothing being caught between belts and pulleys. Make sure engine is shut off and ignition key is removed before inspecting belts.

All drive belts must be periodically inspected for condition and tension.

Perform the following inspections of alternator drive belt and seawater pickup pump drive belt.

If any drive belts need replacement or tension needs adjustment see your Authorized MerCruiser Dealer.

1 Alternator Drive Belt - Inspect drive belt for excessive wear or damage.

Check belt tension by depressing upper strand of belt at point shown. Belt should depress 1/2 in. (13mm)

2 Seawater Pump Drive Belt - Inspect drive belt for excessive wear or damage.

A Models with Seawater Pump

B Models with Seawater/Fuel Pump (L.H. Rotation)

Check belt tension by depressing upper strand of belt at point shown. Belt should depress 1/4 in. (6mm).

Seawater Pump Impeller

This maintenance should be performed by an Authorized MerCruiser Dealer.

3 Seawater pump impeller should be inspected whenever insufficient seawater flow is suspected (if operating temperature exceeds normal range).

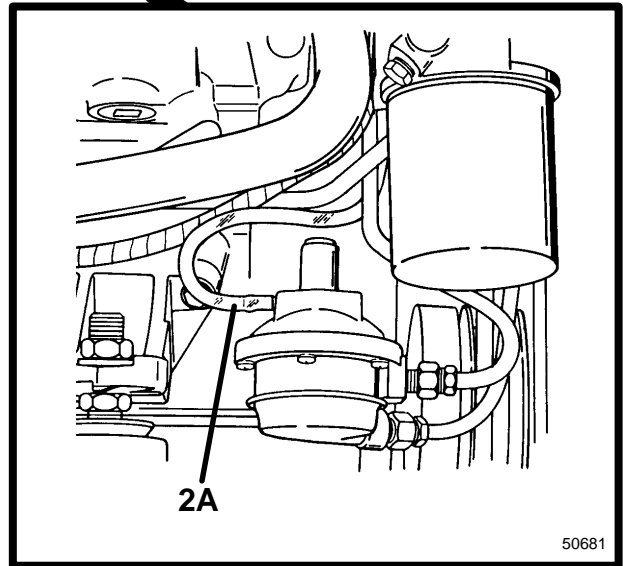
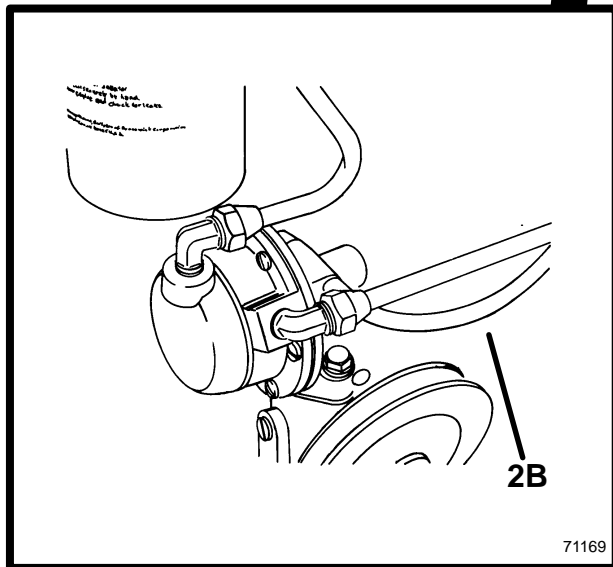
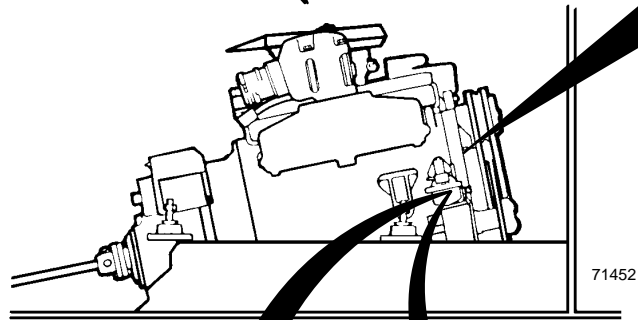
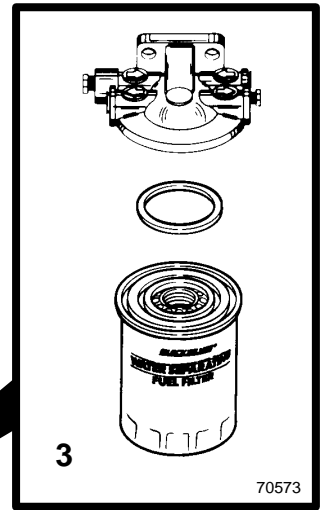
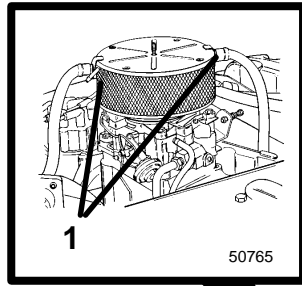
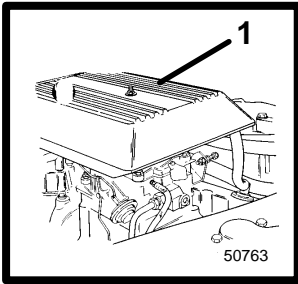

Flame Arrestor And Crankcase Vent Hoses

WARNING

Be careful when servicing flame arrestor and crankcase ventilation hose; gasoline is extremely flammable and highly explosive under certain conditions. Be sure that ignition key is “OFF”. DO NOT smoke or allow sources fo spark or open flame in area when servicing flame arrestor and crankcase ventilation hose.

1 Remove nut, sealing washer and cover. Then remove vent hoses and flame arrestor. Clean flame arrestor and vent hoses in solvent and dry. Install all parts and tighten nut securely.

Fuel Pump Sight Tube Inspection

2 The engine fuel pump is equipped with a sight tube which gives visible evidence of a ruptured fuel pump diaphragm. If fuel is visible in tube, fuel pump should be replaced by your Authorized MerCruiser Dealer immediately.

A Models with Seawater Pump Only

B Models with Seawater/Fuel Pump (Combination)

Water Separating Fuel Filter (If So Equipped)

WARNING

Be careful when changing water separating fuel filter. Gasoline is extremely flammable and highly explosive under certain conditions. Be sure ignition key is OFF. Do not smoke or allow spark or open flame in area when changing fuel filter. Wipe up any spilled fuel immediately. Make sure no fuel leaks exist before closing engine hatch.

3 Remove water separating fuel filter (by turning counterclockwise) and sealing ring from mounting bracket and discard.

Coat sealing rings on new filter with motor oil. Thread filter (clockwise) onto bracket and tighten securely by hand. Do not use a filter wrench.

Start and run engine. Check filter connection for gasoline leaks. If leaks exist, recheck filter installation. If leaks continue, stop engine immediately and contact your Authorized MerCruiser Dealer.

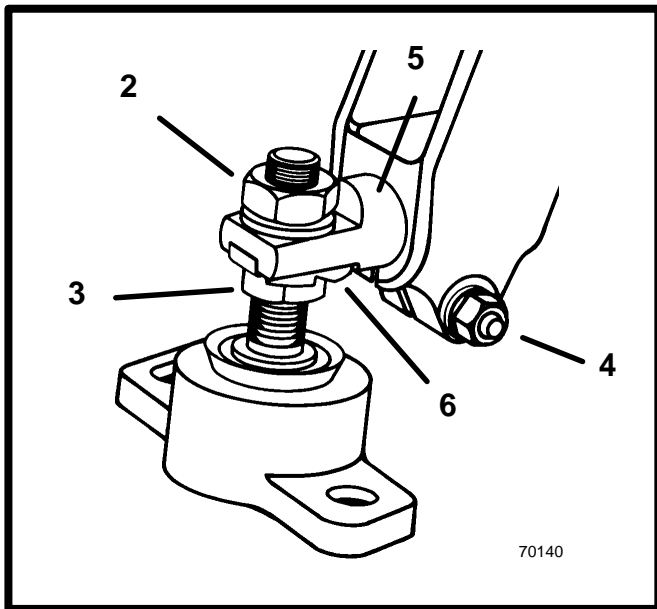
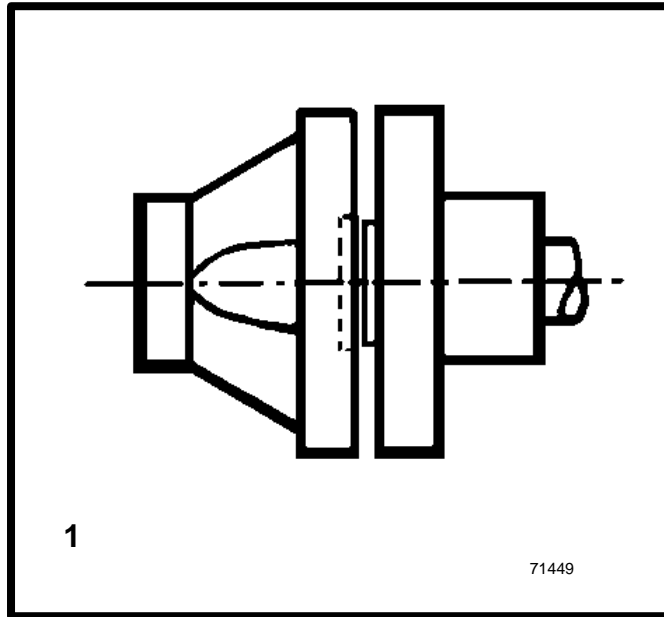

TYPICAL FRONT MOUNT

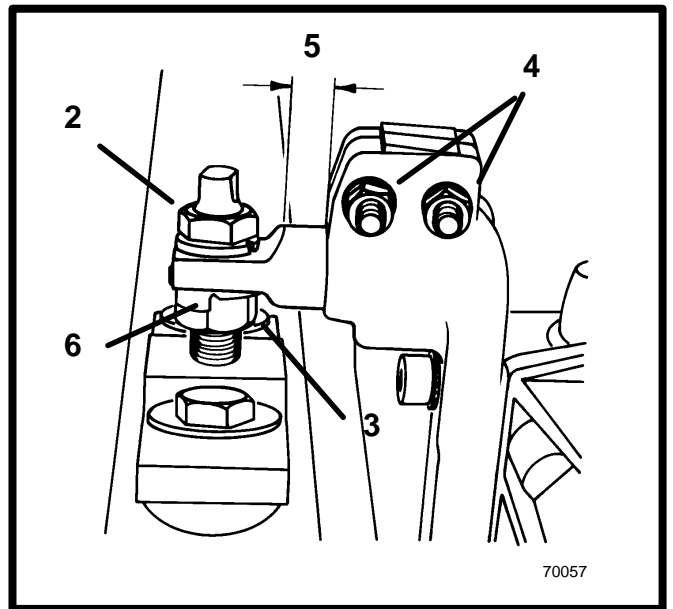

TYPICAL REAR MOUNT

Engine Alignment

Engine alignment should be checked by your Authorized MerCruiser Dealer at specified intervals.

IMPORTANT: Engine alignment must be checked with boat in the water, fuel tanks filled and with a normal load on board.

1 Engine must be aligned so that transmission and propeller shaft coupling centerlines are aligned and coupling faces are parallel within .003 in. (.07mm).

After alignment is correct, coupler attaching screws and nuts must be torqued to 50 lb. ft. (68 N.m).

2 Locking Nut - After alignment is correct, tighten securely.

3 Adjusting Nut - Turning nut clockwise lowers engine.

IMPORTANT: Both front mounts (or rear mounts) adjusting nuts must be turned equally to keep engine level from side to side.

4 Clamping Screw(s) and Nut(s) - Loosen to allow sideways movement of engine. After alignment is correct, tighten securely.

NOTE: *Some rear mounts have two clamping screws and nuts, on each side, others have only one clamping screw and nut, on each side.*

5 Maximum mount trunnion extension is 3/4 in. (20mm).

6 Tab Washer - After alignment is correct, bend tab against flat on adjust nut.

IMPORTANT: Be sure to recheck engine mount fasteners for adequate tightness after completing engine alignment.

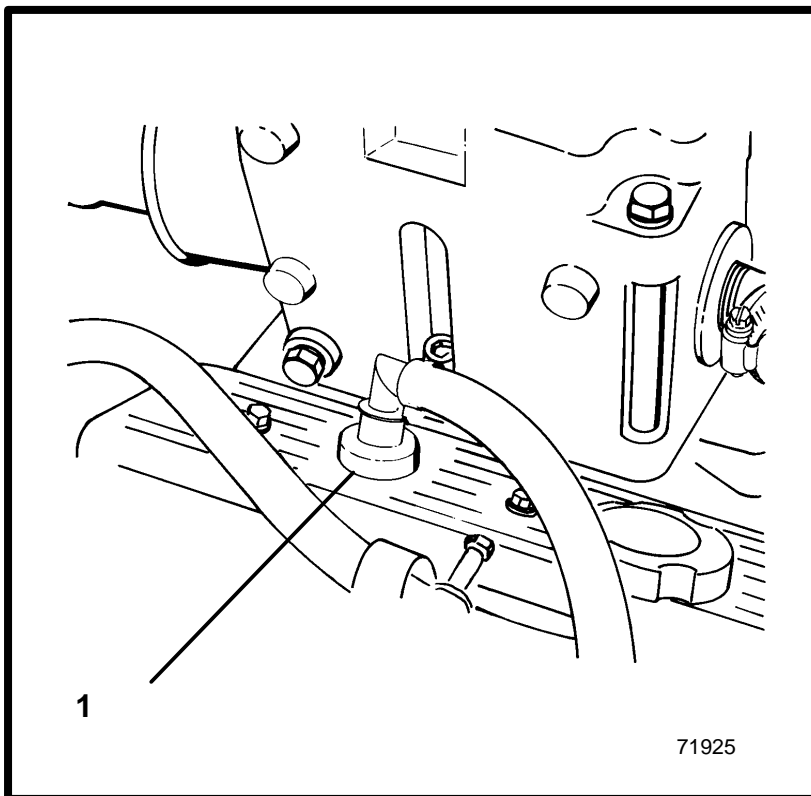
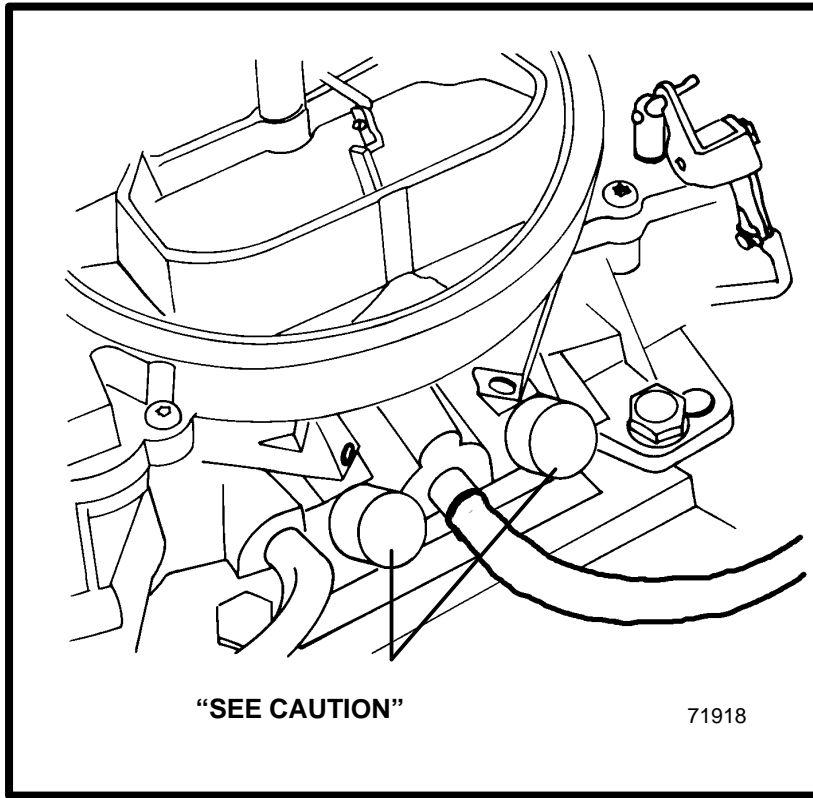

Emissions

CA399

The following information applies only to engines with a special emissions kit installed. If the kit has been installed, your engine complies with "Stage 1" Bodensee and Swiss Regulations.

CA398

Sealed Carburetor Mixture Screws

The carburetor on this engine has seals on the carburetor mixture screws. These seals prevent adjustment of the fuel mixture settings.

CAUTION

Do not remove mixture screw seals and/or attempt to adjust fuel mixture setting. Tampering with the mixture setting on this engine could affect the exhaust emissions level, thus voiding the emissions certification. These seals should only be removed by an authorized dealer or emissions testing agency.

CA99

Changing Positive Crankcase Ventilation Valve (PCV)

This engine is equipped with a positive crankcase ventilation valve (PCV). This valve should be changed every 100 hours of operation or at least once a year, whichever occurs first.

- 1 Remove PCV valve from port valve cover. Disconnect it from the hose and discard valve. Install new PCV valve in valve cover and reconnect hose. Ensure valve is tightly seated in valve cover.

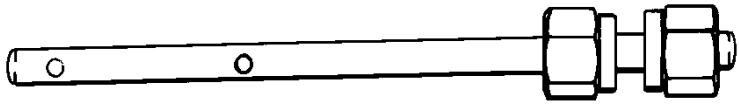

71926

2

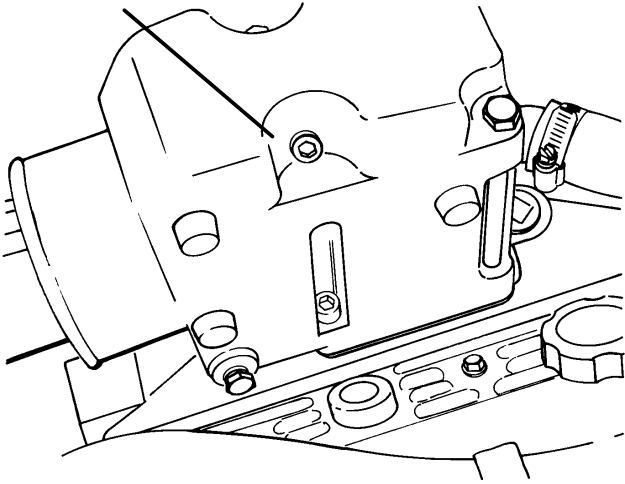

71921

3

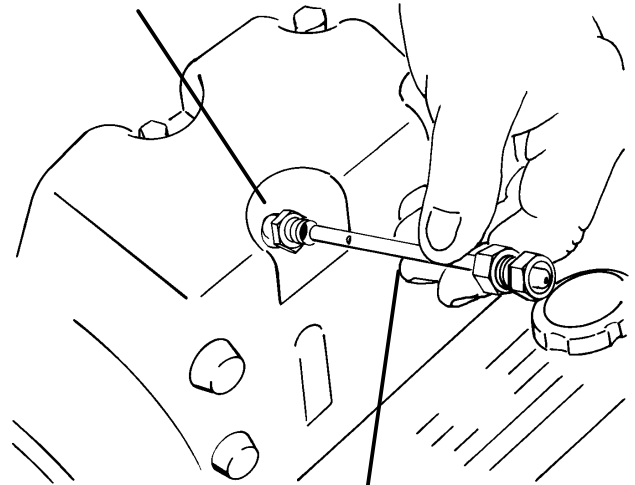

71923

4

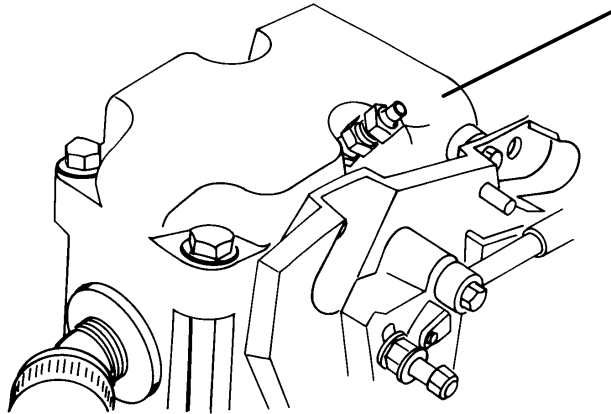

71919

Emissions Testing

Your engine is equipped with special design features and special tuning to minimize the emission output from the engine. You should follow:

- Recommended maintenance schedules particularly as to the ignition system.
- Proper engine tuning procedures to ensure these features remain in good operating order.
- Proper steps to maintain the engine within specifications.

Use only MerCruiser replacement parts to ensure compliance with emission regulations.

Installing Test Probes

IMPORTANT: The testing dealer or agency will be equipped with the appropriate test equipment and adapters for this engine. The only item that must be supplied by the boat owner/operator is the exhaust elbow test probes. These test probes should have been provided with your power package. They should be carried aboard you boat at all times.

- 2** Remove plugs from both exhaust elbows.
- 3** Install exhaust elbow adapter fittings into elbows. Apply Loctite Pipe Sealant with Teflon to threads that go into elbow. Tighten it securely.
- 4** Insert exhaust probes into fittings and tighten securely.

The testing agency will connect their adapters and test equipment to the probes to conduct the test. Once the test is complete, remove the test probes and fittings. Apply Quicksilver Perfect Seal to the threads of both plugs and reinstall them into elbows. Be sure to save the test probes and fittings, and keep them onboard for future use.

Miscellaneous Maintenance

Battery

All lead acid batteries discharge when not in use. Recharge every 30 to 45 days, or when specific gravity drops below battery manufacturer's specifications.

Refer to specific instructions and warnings accompanying your battery. If this information is not available, observe the following precautions when handling a battery.

⚠ WARNING

Do not use jumper cables and a booster battery to start engine. Do not recharge a weak battery in the boat. Remove battery and recharge in a ventilated area away from fuel vapors, sparks or flames.

⚠ WARNING

Batteries contain acid which can cause severe burns-Avoid contact with skin, eyes and clothing. Batteries also produce hydrogen and oxygen gases when being charged. This explosive gas escapes fill/vent cell caps and may form an explosive atmosphere around the battery for several hours after it has been charged. Sparks or flames can ignite the gas and cause an explosion which may shatter the battery and could cause blindness or other serious injury.

Safety glasses and rubber gloves are recommended when handling batteries or filling with electrolyte. Hydrogen gases that escape from the battery during charging are explosive. When charging batteries, be sure battery compartment or area where batteries are located, is well-vented. Battery electrolyte is a corrosive acid and should be handled with care. If electrolyte is spilled or splashed on any part of the body, immediately flush the exposed area with liberal amounts of water and obtain medical aid as soon as possible.

CC71

Bottom Of Boat

To maintain maximum speed, the following conditions of the boat bottom should be observed:

- Clean, free of barnacles and marine growth.
- Free of distortion, nearly flat where it contacts water.
- Straight and smooth, fore and aft.

CC72

Antifouling Paints

In some areas, it may be advisable to paint bottom to help prevent marine growth. See your dealer for recommendations for your boat.

CA105

Inspection And Maintenance

Inspect power package often, and at regular intervals, to help maintain its top operating performance, and correct potential problems before they occur. The entire power package should be checked carefully, including all accessible engine parts.

Check for loose, damaged or missing parts, hoses and clamps; tighten or replace as required.

Check plug leads and electrical leads for damage.

Remove and inspect propeller. If badly nicked, bent or cracked, see your dealer.

Repair nicks and corrosion damage on power package exterior finish. Use Quicksilver spray paints - see your Authorized MerCruiser Dealer.

Cold Weather or Extended Storage

Power Package Layup

IMPORTANT: MerCruiser strongly recommends that this service should be performed by an Authorized MerCruiser Dealer. Damage caused by freezing IS NOT covered by the MerCruiser Limited Warranty.

CAUTION

DO NOT operate engine without water flowing thru seawater pickup pump, as pump impeller may be damaged and subsequent overheating damage to engine or stern drive unit may result.

IMPORTANT: Before starting engine a water source must be attached to the seawater pump. Follow all warnings, and flushing attachment procedures stated in “FLUSHING COOLING SYSTEM.”

- 1 Run engine sufficiently to bring it up to normal operating temperature. Shut off engine and change oil and oil filter.
- 2 Flush cooling system. Refer to “Flushing Cooling System” procedure shown earlier in this manual.

WARNING

Be sure engine compartment is well ventilated and no gasoline vapors are present during the following operation - to prevent a potential fire hazard.

- 3 Remove flame arrestor and restart engine. While operating engine at fast idle (1000-1500 RPM), fog internal surfaces of engine by squirting approximately 8 ounces (227 g) of Quicksilver Storage Seal (or if not available, SAE 20W motor oil) into carburetor bores. Stall engine by squirting last 2 ounces (57 g) of Storage Seal (or oil) rapidly into carburetor. Turn ignition key to OFF position.
- 4 If boat is to be placed in storage and has been using fuel containing alcohol (if fuel without alcohol was not available), carburetors must be run dry at idle RPM. Fuel tanks should be drained completely and Quicksilver Gasoline Stabilizer for Marine Engines added to any fuel remaining in the tank. Refer to “FUEL REQUIREMENTS” for additional information.
- 5 If fuel WITHOUT alcohol is available: Fill fuel tank(s) with fresh gasoline and a sufficient amount of Quicksilver Gasoline Stabilizer for Marine Engines to treat gasoline. Follow instructions on container.
- 6 Close fuel shutoff valve, if so equipped.

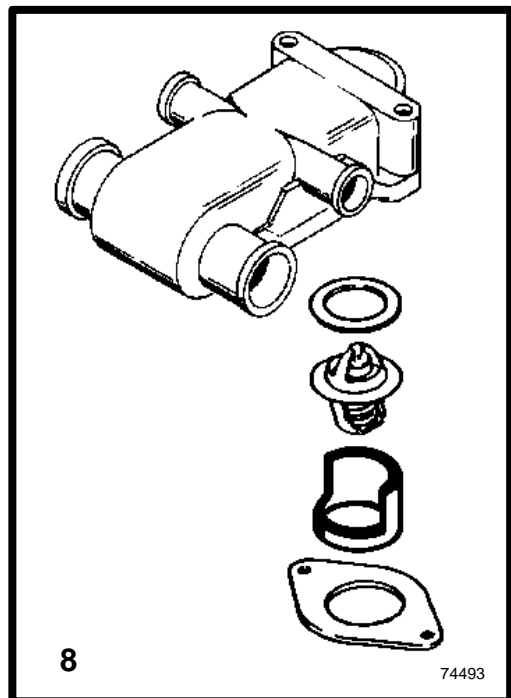
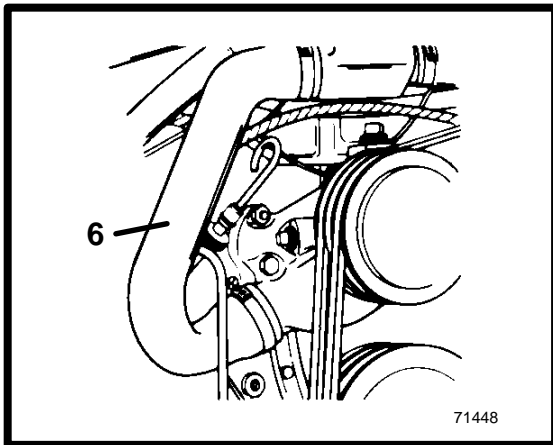
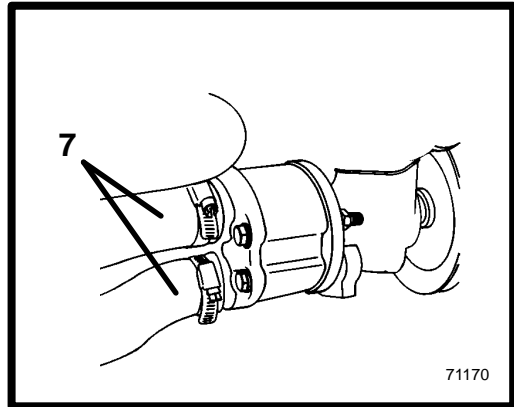
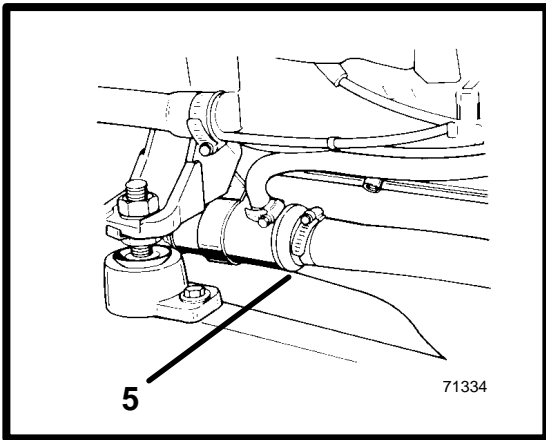
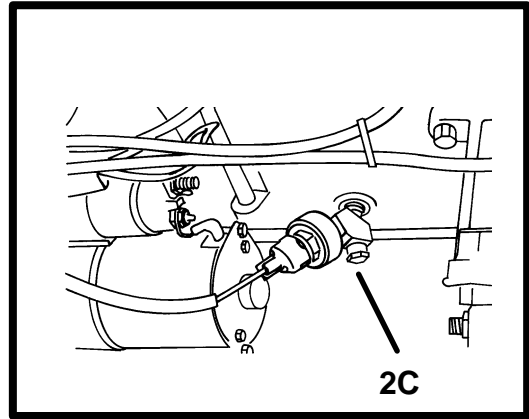
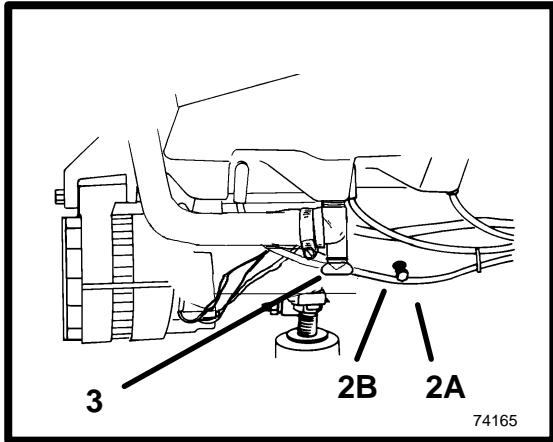

Draining Instructions

DRAINING SEAWATER (RAW-WATER) COOLED MODELS

⚠ CAUTION

If boat is to remain in water after draining, seawater inlet hose must be removed and plugged to prevent a siphoning action that may occur, allowing seawater to flow from the drain holes or removed hoses.

IMPORTANT: Boat must be as level as possible to ensure complete draining of cooling system.

⚠ CAUTION

Seawater section of cooling system **MUST BE COMPLETELY** drained for winter storage, or immediately after cold weather use, if the possibility of freezing temperatures exist. Failure to comply may result in trapped water causing freeze and/or corrosion damage to engine.

- 1 Ensure engine is as level as possible to ensure complete draining of cooling system.
- 2 **Remove** drain plugs from cylinder block as follows:
 - A 7.4L and 8.2L (Port and Starboard)** - from cylinder block
 - B 5.7L (Port Side)** - from cylinder block.
 - C 5.7L (Starboard Side)** - from Y-fitting. Do not disturb the Y-fitting when removing the drain plug. There is an ignition control "Knock Sensor" in the upper hole of the fitting. This sensor must not be loosened or removed. It is tightened to a critical specification at the factory.
- 3 **Remove** drain plugs (port and stbd) from bottom of exhaust manifolds.
- 4 **Repeatedly** clean out drain holes using a stiff piece of wire. Do this until entire system is drained.

NOTE: It may be necessary to lift or bend hoses to allow water to drain completely. Crank engine over slightly to purge any water trapped in seawater pickup pump. Do not allow engine to start.

Loosen hose clamps and remove the following hoses:

- 5 From transmission cooler, or transmission and engine oil cooler as applicable.
- 6 From engine circulating pump.
- 7 From seawater pickup pump (both hoses).

After cooling system has been drained completely, install drain plugs, reconnect hoses and tighten all hose clamps securely.

IMPORTANT: MerCruiser recommends that propylene glycol (a nontoxic and environmentally safe) anti-freeze be used in the seawater section of the cooling system for cold weather or extended storage. Make sure that the propylene glycol antifreeze contains a rust inhibitor and is recommended for use in marine engines. Be certain to follow the propylene glycol manufacturer's recommendations.

8 For additional assurance against freezing and rust, remove the thermostat cover and thermostat. Fill the engine seawater cooling system with a mixture of antifreeze and tap water mixed to manufacturer's recommendation to protect engine to the lowest temperature to which it will be exposed during cold weather or extended storage. Using a new gasket, reinstall thermostat and cover. Tighten cover bolts securely.

Perform all checks, inspections, lubrication, and fluid changes outlined in MAINTENANCE CHART under AT LEAST ONCE A YEAR.

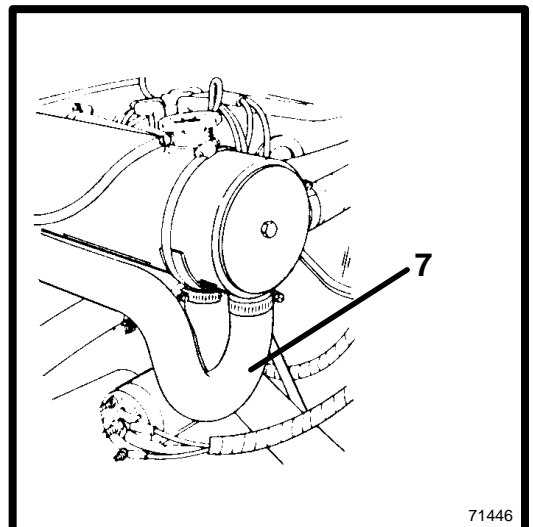
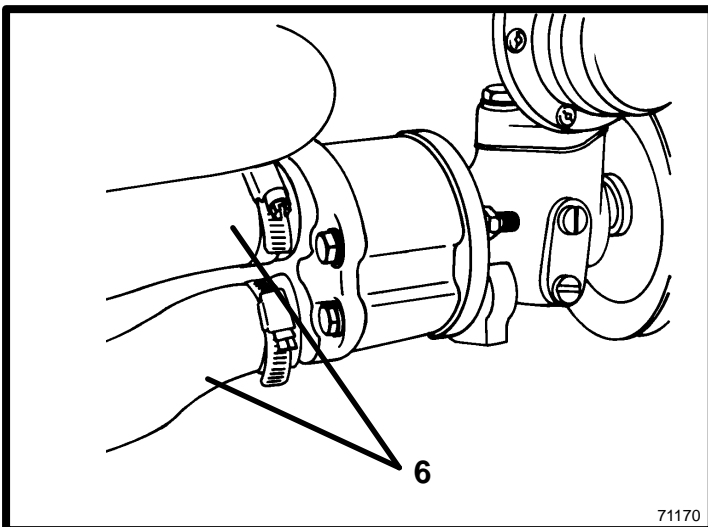
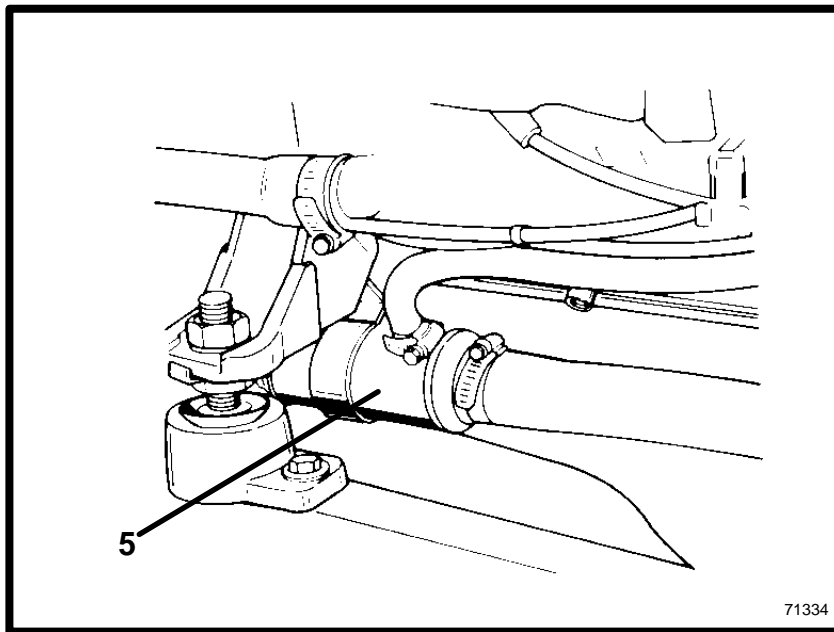
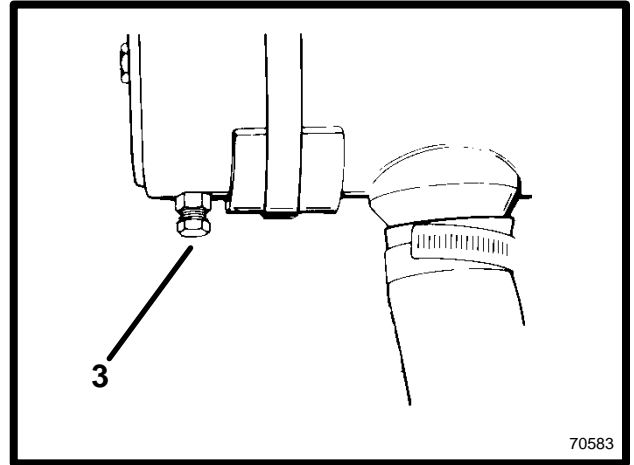
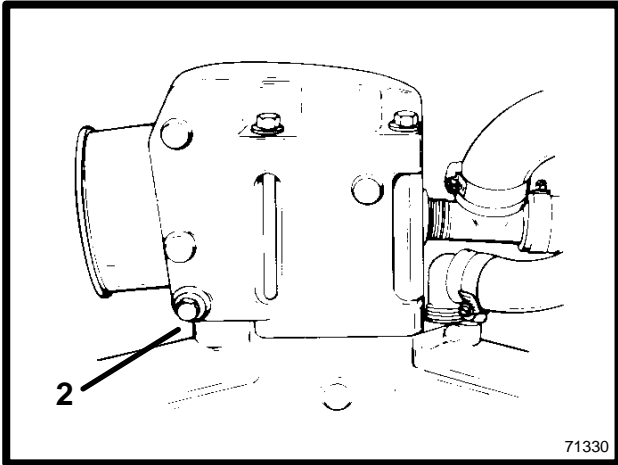

DRAINING CLOSED COOLING (COOLANT) MODELS

IMPORTANT: Drain seawater section of closed cooling system only.

⚠ CAUTION

If boat is to remain in water after draining seawater inlet hose must be removed and plugged to prevent a siphoning action that may occur allowing seawater to flow from the drain holes or removed hoses.

IMPORTANT: Boat must be as level as possible to ensure complete draining of cooling system.

⚠ CAUTION

Seawater section of cooling system **MUST BE COMPLETELY** drained for winter storage or immediately after cold weather use if the possibility of freezing temperatures exist. Failure to comply may result in trapped water causing freeze and/or corrosion damage to engine.

IMPORTANT: Closed cooling section must be kept filled year-round with recommended coolant. If engine will be exposed to freezing temperatures, make sure closed cooling section is filled with an ethylene glycol antifreeze and water solution properly mixed to protect engine to lowest temperature to which it will be exposed.

IMPORTANT: Do not use Propylene Glycol Antifreeze in the closed cooling section of the engine.

IMPORTANT: Models equipped with stainless steel exhaust elbows do not have a drain plug in exhaust elbows.

- 1 Ensure engine is as level as possible to ensure complete draining of cooling system.
- 2 Remove drain plug from both exhaust elbows (if so equipped).

NOTE: Models with exhaust elbow risers, remove drain plugs from risers.

- 3 Remove drain plug from heat exchanger.
- 4 Repeatedly clean out drain holes using a stiff piece of wire. Do this until entire system is drained.
- 5 Remove drain plug from transmission cooler and/or oil cooler, as applicable.

Loosen hose clamps and disconnect the following hoses:

NOTE: It may be necessary to lift or bend hoses to allow water to drain completely. Crank engine over slightly to purge any water trapped in seawater pickup pump. Do not allow engine to start.

- 6 From seawater pickup pump (Both Hoses).
- 7 From heat exchanger.

After seawater section of cooling system has drained completely, coat threads of drain plugs with Quicksilver Perfect Seal and reinstall. Reconnect hoses and tighten all hose clamps securely.

Perform all checks, inspections, lubrication, and fluid changes outlined in MAINTENANCE CHART under AT LEAST ONCE A YEAR.

CA115

BATTERY WINTER STORAGE

Follow battery manufacturer's instructions for storage.

CC81

Power Package Recommissioning

WARNING

To prevent possible injury or damage to equipment, do not install battery until all maintenance has been performed on engine.

- Check that all cooling system hoses are connected properly and hose clamps are tight.

CAUTION

When installing battery, be sure to connect **POSITIVE (+)** battery cable to **POSITIVE (+)** battery terminal **FIRST**, and **NEGATIVE (-)** battery cable to **NEGATIVE (-)** battery terminal **LAST**. If battery cables are reversed, or connection order is reversed, electrical system damage will result.

- Install fully charged battery. Clean battery cable clamps and terminals and reconnect cables (see CAUTION listed above). Secure each cable clamp when connecting.
- Coat terminal connections with a battery terminal anti-corrosion agent.
- Perform all checks in OPERATION CHART in the BEFORE STARTING column.

CAUTION

Refer to precautions listed under “**FLUSHING COOLING SYSTEM**” before starting engine.

- Start engine and closely observe instrumentation to make sure that all systems are functioning correctly.
- Carefully inspect engine for fuel, oil, fluid, water and exhaust leaks.
- Check steering system, shift and throttle control for proper operation.
- Check fuel pump sight tube for evidence of fuel (indicating a ruptured fuel pump diaphragm).

Troubleshooting

Trouble	Possible Cause	Remedy
Starter motor won't crank engine or cranks it very slowly	<ul style="list-style-type: none"> • Battery switch turned off (if so equipped) • Remote control not in neutral position • Open circuit breaker or blown fuse. • Loose or dirty electrical connections or damaged wiring • Bad battery 	<ul style="list-style-type: none"> • Turn switch on. • Position control lever properly. Lever MUST BE EXACTLY in neutral. • Check and reset circuit breaker or replace fuse. • Check all associated electrical connections and wires (especially battery cables). Refer to wiring diagram, following. Clean and tighten faulty connection. Repair or replace wiring. • Test and replace if bad.
Engine won't start or is hard to start	<ul style="list-style-type: none"> • Improper starting procedure • Empty fuel tank or fuel shut-off valve closed (if so equipped) • Faulty fuel pump • Choke not operating properly • Engine flooded • Faulty ignition system component • Clogged fuel filters • Contaminated fuel • Fuel line or tank vent line kinked or clogged 	<ul style="list-style-type: none"> • Review starting procedure under "Operation Instructions." • Fill tank or open valve. • Check sight-tube for fuel. Have your dealer replace pump, if fuel is present. • Check that choke is closed when engine is cold. Check that it opens when engine warms up. • Do not attempt to start engine for at least 5 minutes; then, fully advance throttle (making sure remote control is in neutral position) and crank engine. • Service ignition system. • Replace filters. • Inspect fuel for water or other contaminants. If contaminated, drain tank and flush with fresh fuel. • Replace kinked lines or blow out lines with compressed air to remove obstruction.

Trouble	Possible Cause	Remedy
Engine runs rough, misses and/or backfires	<ul style="list-style-type: none"> • Choke not operating properly • Faulty fuel pump • Idle speed too low (if engine is rough at idle) • Faulty ignition system component • Clogged fuel filters • Contaminated fuel • Kinked or clogged fuel line or fuel tank vent line • Flame arrestor plugged with foreign material. 	<ul style="list-style-type: none"> • Check that choke is closed when engine is cold. Check that it opens when engine warms up. • Check sight tube. Have your dealer replace pump, if fuel is present. • Check idle speed and adjust, if necessary. • Service ignition system • Replace filters. • Inspect fuel for water or other contaminants. If contaminated, drain tank and flush with fresh fuel. • Replace line if kinked. Blow out line with compressed air to remove obstruction. • Clean flame arrestor.
Poor performance	<ul style="list-style-type: none"> • Throttle not fully open • Damaged or improper propeller • Excessive bilge water • Boat overloaded or load improperly distributed • Boat bottom fouled or damaged • Flame arrestor dirty • Engine overheating • Ignition or carburetion problem 	<ul style="list-style-type: none"> • Inspect cable and linkages for binding, obstruction or loose fasteners. • Replace. • Drain and check for cause of entry. • Reduce load or redistribute load more evenly. • Clean or repair as necessary. • Clean flame arrestor. • See "Excessive engine temperature". • Refer to "Engine runs rough, misses and/or backfires".
Excessive engine temperature Cause applicable to engines with optional Closed Cooling System only	<ul style="list-style-type: none"> • Water inlet valve closed (if so equipped) • Alternator drive belt loose, broken or in poor condition • Seawater pickup pump drive belt loose, broken or in poor condition. • Water pickup obstructed • Kinked, collapsed or broken hose • Faulty thermostat • Transmission fluid cooler and/or engine oil cooler plugged with foreign material 	<ul style="list-style-type: none"> • Open valve COMPLETELY. • Replace and/or adjust belt. • Replace and/or adjust belt. • Remove obstruction. • Straighten or replace hose. • Replace. • Disconnect hoses from coolers and flush out with a water hose in direction opposite normal water flow. <p>(continued next page)</p>

Trouble	Possible Cause	Remedy
Excessive engine temperature (continued)	<ul style="list-style-type: none"> • Coolant level low in fresh water section • Heat exchanger cores plugged with foreign material • Loss of pressure in fresh water section 	<ul style="list-style-type: none"> • Check for cause of low coolant level and repair. Fill system with proper coolant solution. • Clean. • Check for leaks. Clean, test and inspect pressure cap.
Insufficient engine temperature	<ul style="list-style-type: none"> • Faulty thermostat 	<ul style="list-style-type: none"> • Replace.
Low engine oil pressure	<ul style="list-style-type: none"> • Insufficient oil in crankcase • Excessive oil in crankcase (causing it to become aerated) • Diluted or improper viscosity oil • Engine oil cooler hose kinked (causing excessive oil temperature and thinning of the oil) 	<ul style="list-style-type: none"> • Check and add correct grade and viscosity oil. Check entire engine for leaks. • Check and remove required amount of oil. Check for cause of excessive oil (improper filling, bad fuel pump, etc.). • Change oil and oil filter, being sure to use correct grade and viscosity oil. Determine cause for dilution (excessive idling, faulty fuel pump, etc.). • Straighten hose or replace if damaged.
Excessive transmission fluid temperature or slipping transmission	<ul style="list-style-type: none"> • Low fluid level • Transmission shift lever not positioned properly (causing clutches to slip and overheat fluid) • Fluid cooler hoses kinked 	<ul style="list-style-type: none"> • Maintain fluid level. • Inspect shift linkages and shift lever positioning • Straighten hoses or replace, if damaged.
Battery will not come up on charge	<ul style="list-style-type: none"> • Excessive current draw from battery • Loose or dirty electrical connections or damaged wiring • Alternator drive belt loose or in poor condition • Unacceptable battery condition 	<ul style="list-style-type: none"> • Turn off non-essential accessories. • Check all associated electrical connections and wires (especially battery cables). Clean and tighten faulty connections. Repair or replace damaged wiring. • Replace and/or adjust. • Test battery.
Remote control operates hard, binds, has excessive free-play or makes unusual sounds	<ul style="list-style-type: none"> • Insufficient lubrication on shift and throttle linkages • Loose or missing shift and throttle linkage fasteners • Obstruction in shift or throttle linkages • Shift or throttle cable kinked 	<ul style="list-style-type: none"> • Lubricate. • Check all linkages. If any are loose or missing, SEE YOUR DEALER IMMEDIATELY. • Remove obstruction. • Straighten cable or have your dealer replace cable if damaged beyond repair.

Wiring Diagrams

Quicksilver Instrumentation

Refer to gauge manufacturer's instructions for specific connections.

NOTE 1 Connect Wires Together with Screw and Hex Nut; Apply Liquid Neoprene to Connection and Slide Rubber Sleeve over Connection.

NOTE 2 Power for a Fused Accessory Panel May Be Taken from This Connection. Load Must Not Exceed 40 Amps. Panel Ground Wire Must Be Connected to Instrument Terminal That Has an 8-Gauge Black (Ground) Harness Wire Connected to it.

NOTE 3 Taped back brown-white wire may be used for an accessory. LOAD MUST NOT EXCEED 5 AMPS.

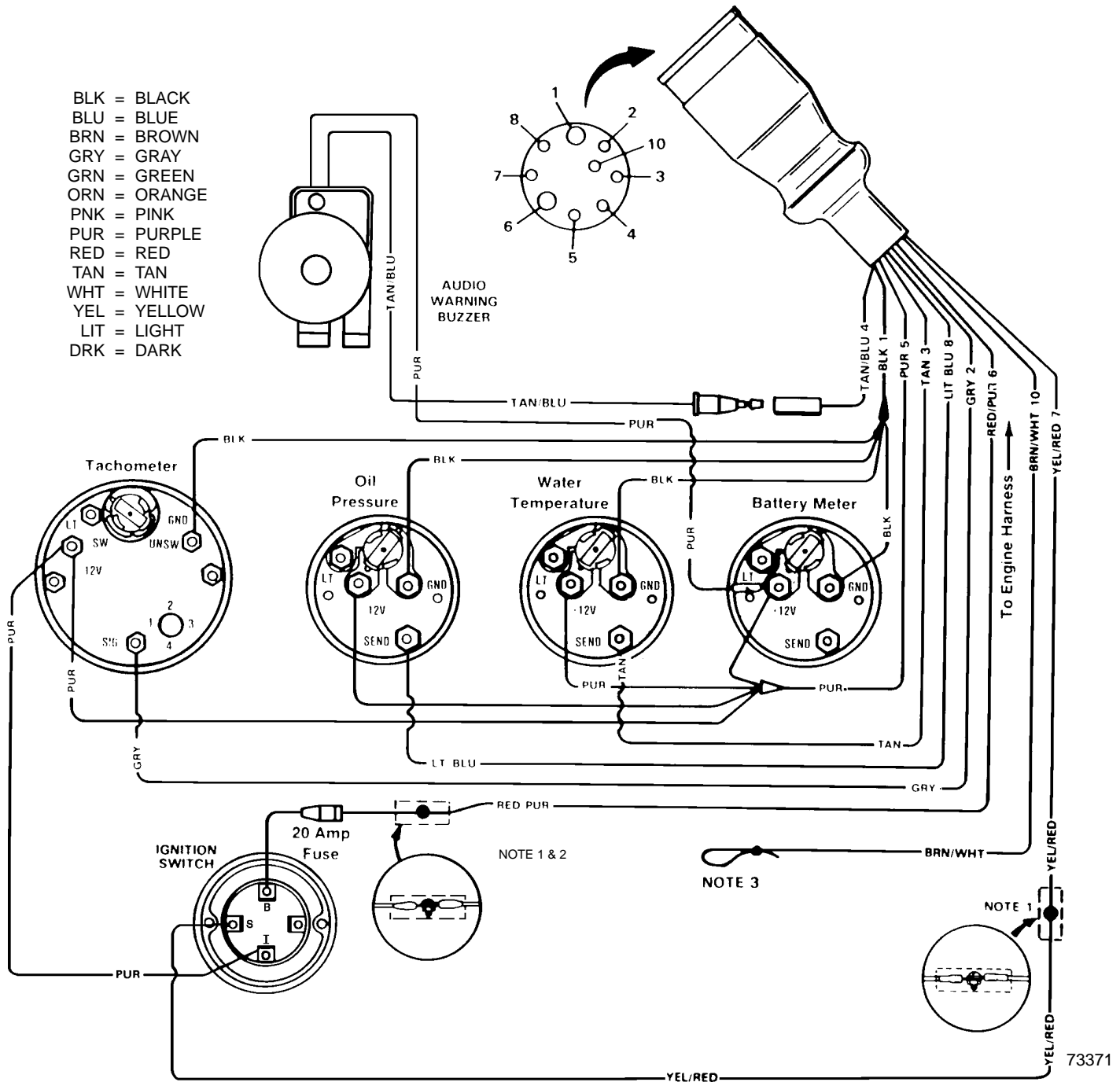

Engine (5.7L, 7.4L and 8.2L)

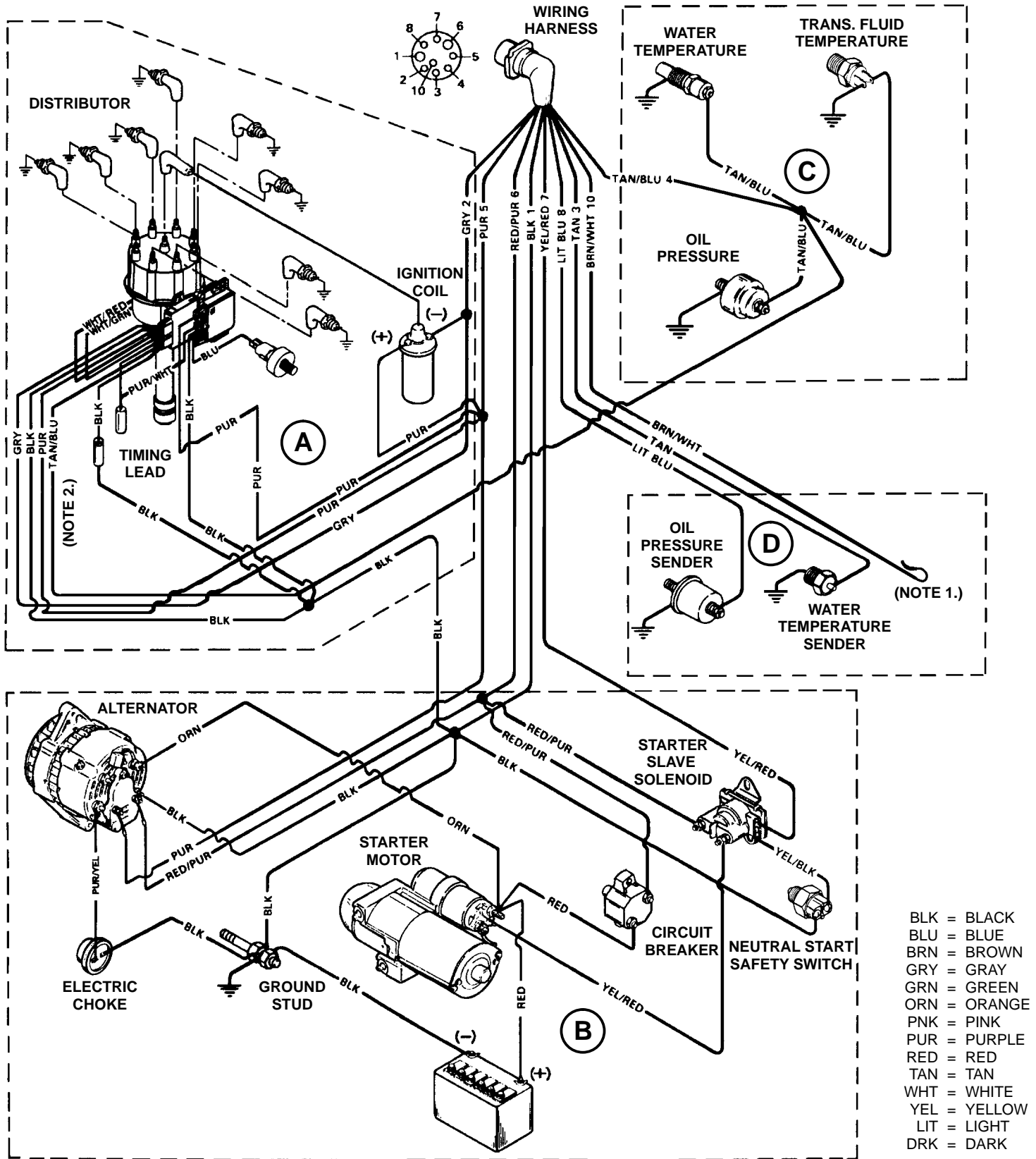

A: Ignition Components C: Audio Warning Components
B: Starting and Charging Components D: Instrumentation Components

NOTE 1: Taped back BROWN-WHITE wire may be used for an Accessory. LOAD MUST NOT EXCEED 5 AMPS.
NOTE 2: TAN/BLUE wire not used.

Water Flow Diagrams

5.7L Seawater Cooled Model

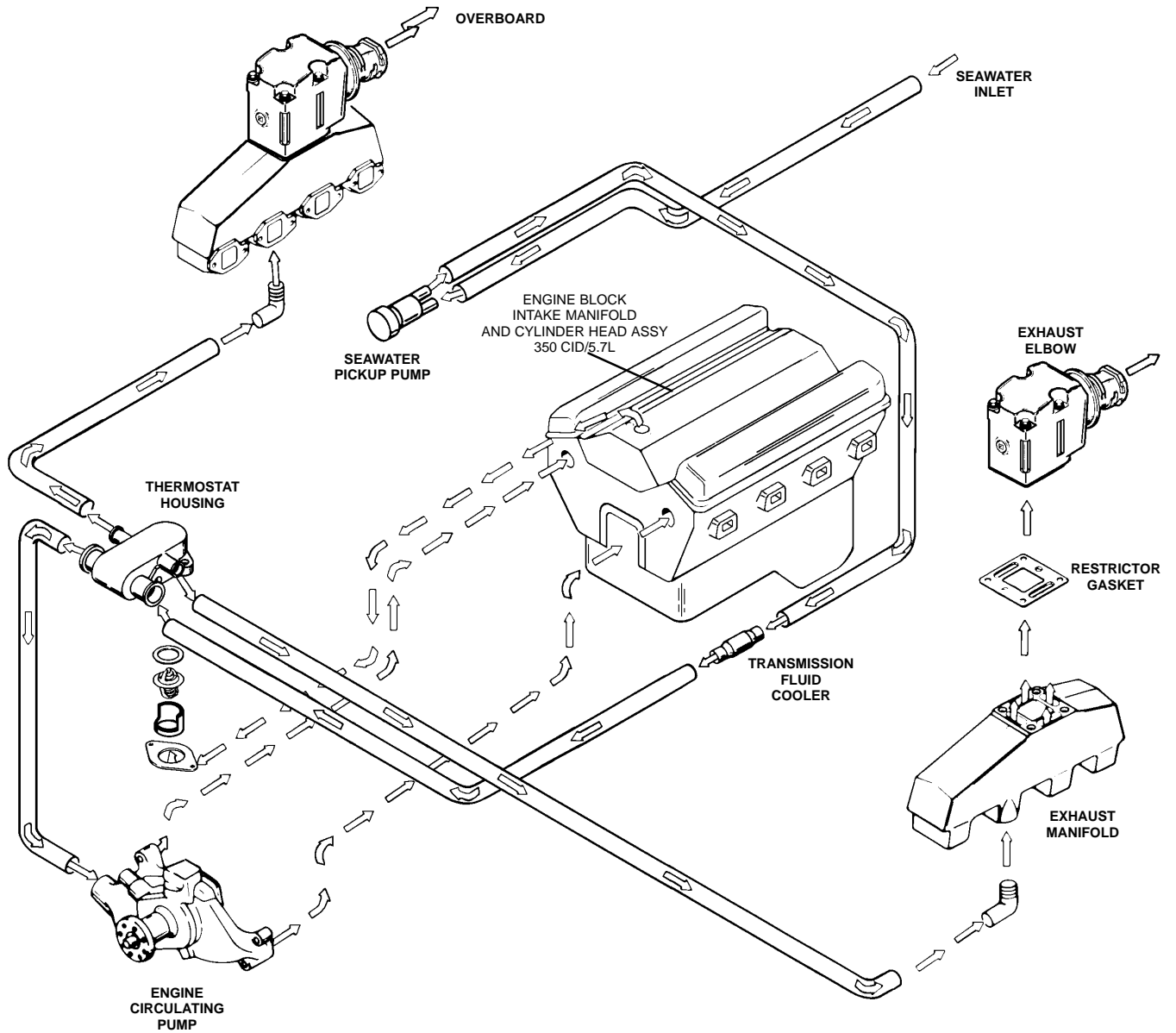

7.4L and 8.2L Seawater Cooled Models

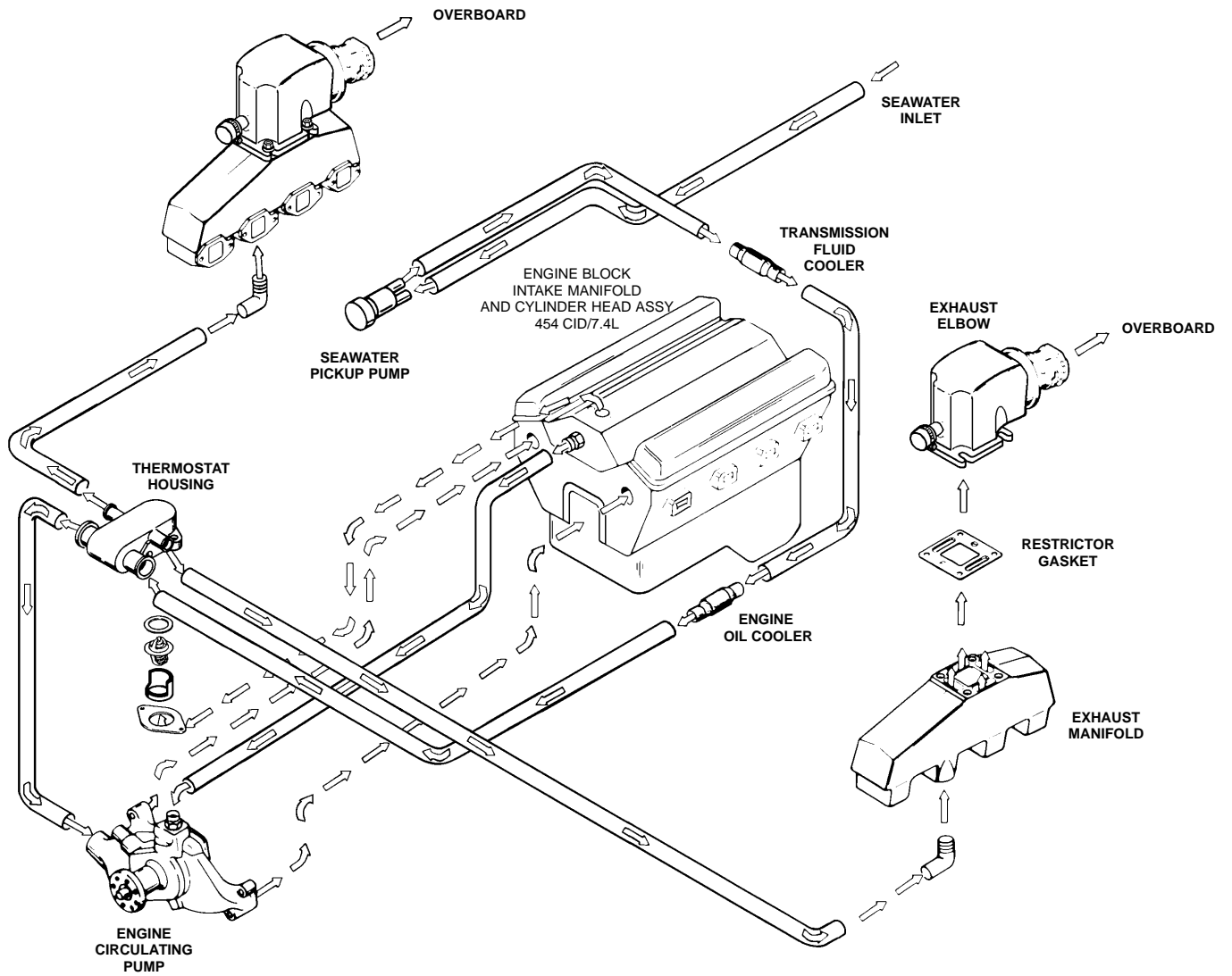

74155

5.7L Closed Cooling Model

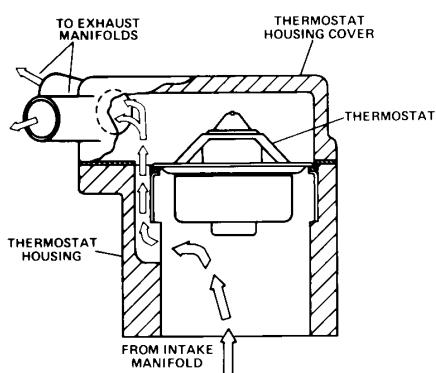
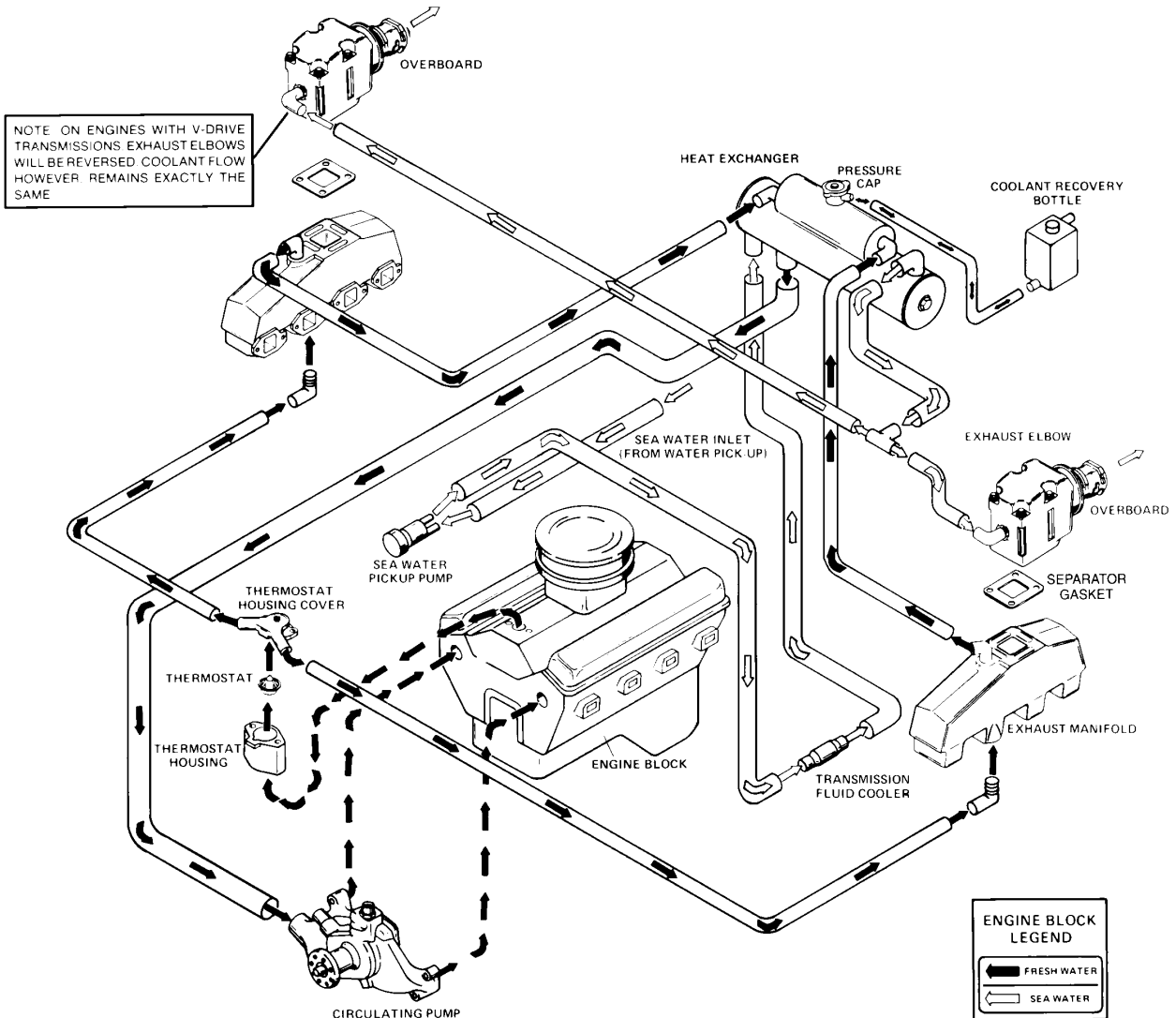

COOLANT FLOW THROUGH THERMOSTAT HOUSING WITH THERMOSTAT CLOSED (ENGINE COLD)

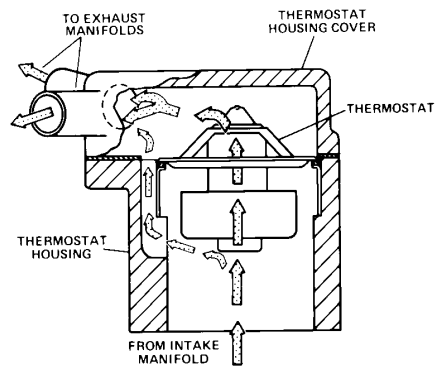
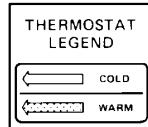

COOLANT FLOW THROUGH THERMOSTAT HOUSING WITH THERMOSTAT OPEN (ENGINE WARM)

7.4L Closed Cooling Model

NOTE: ON ENGINES WITH V-DRIVE TRANSMISSIONS, EXHAUST ELBOWS WILL BE REVERSED. COOLANT FLOW HOWEVER, REMAINS THE SAME.

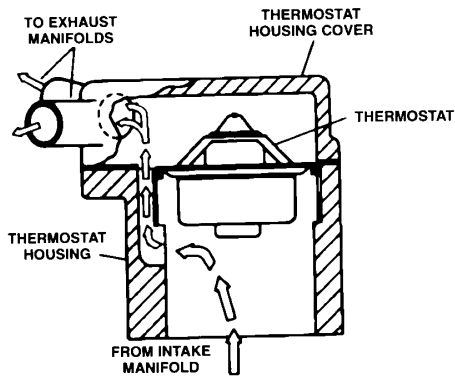
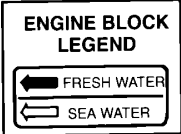
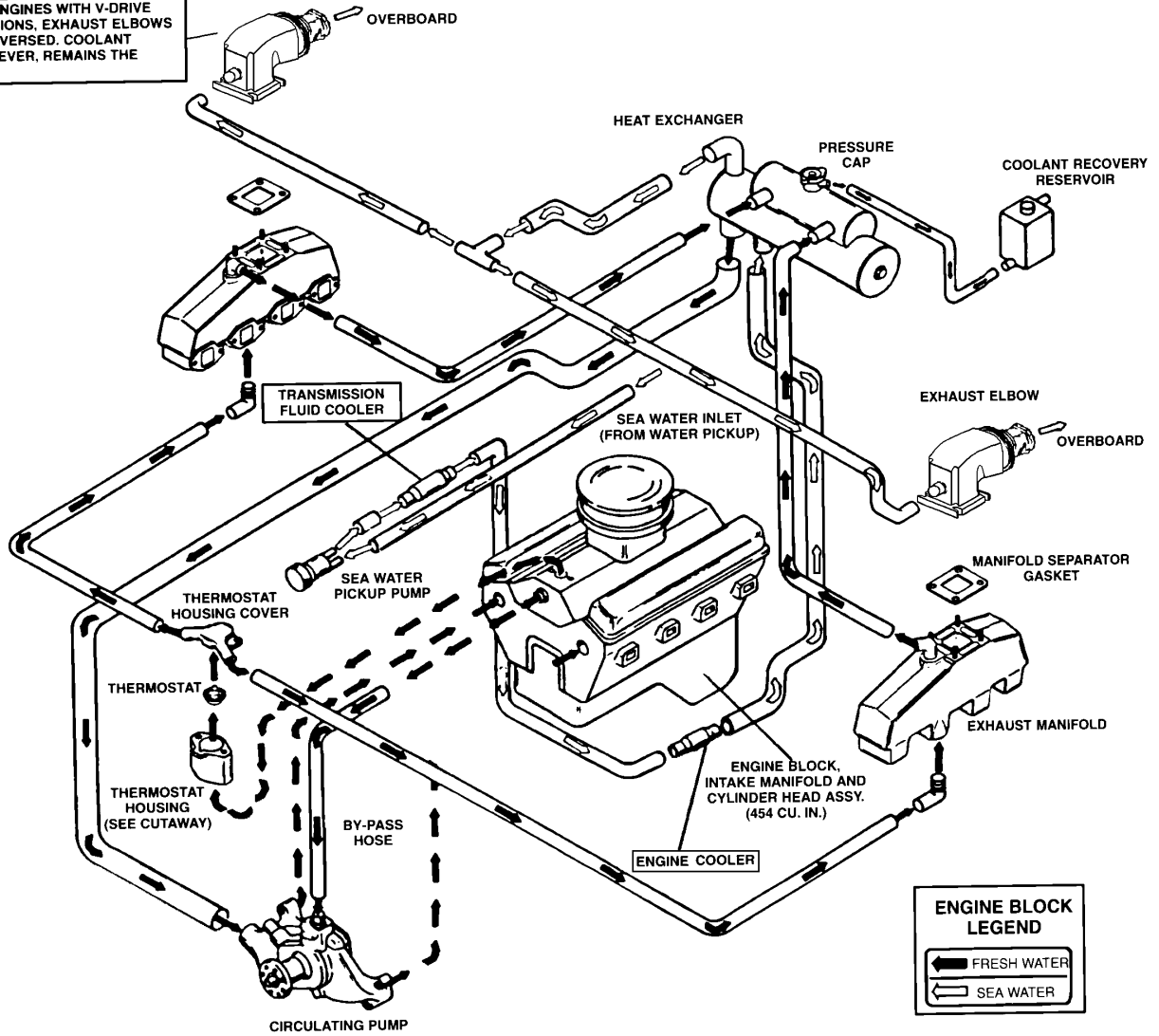

COOLANT FLOW THROUGH THERMOSTAT HOUSING WITH THERMOSTAT CLOSED (ENGINE COLD)

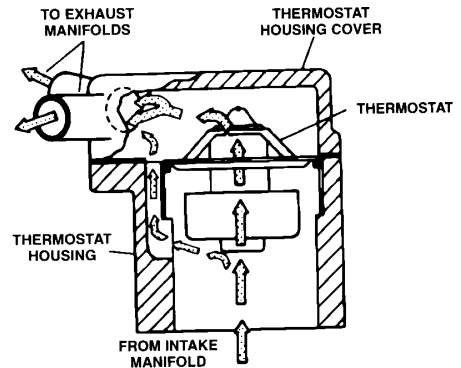
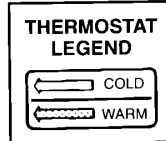

COOLANT FLOW THROUGH THERMOSTAT HOUSING WITH THERMOSTAT OPEN (ENGINE WARM)

8.2L Closed Cooling Model

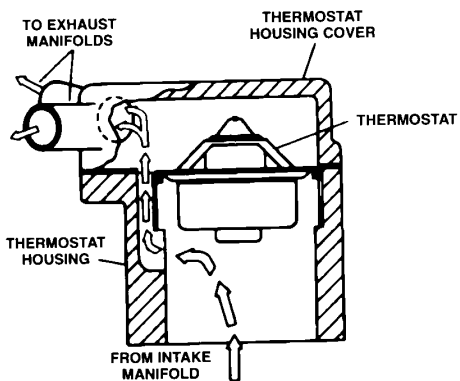
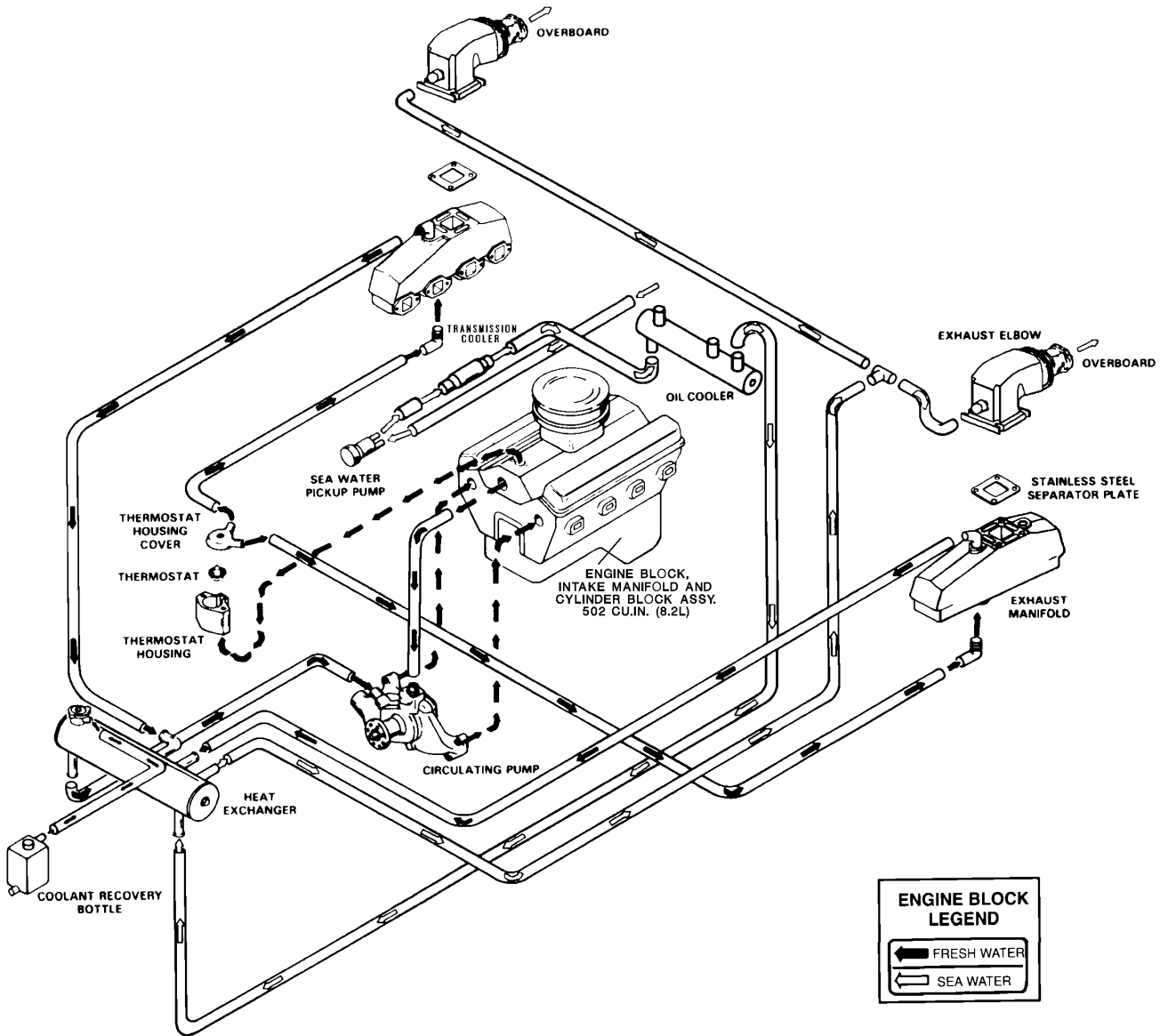

COOLANT FLOW THROUGH THERMOSTAT HOUSING WITH THERMOSTAT CLOSED (ENGINE COLD)

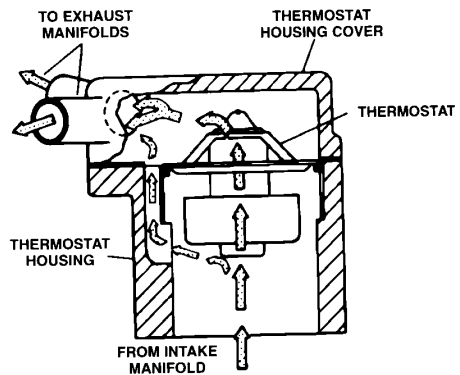
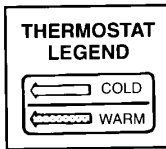

COOLANT FLOW THROUGH THERMOSTAT HOUSING WITH THERMOSTAT OPEN (ENGINE WARM)

Warranty Information

Owner Warranty Registration

UNITED STATES AND CANADA ONLY

- It is important that your selling dealer fills out the Warranty Registration Card completely and mails it to the factory immediately upon sale of the new product.
- It identifies name and address of the original purchaser, product model and serial number(s), date of sale, type of use and selling dealer's code, name and address. The dealer also certifies that you are the original purchaser and user of the product.
- Upon receipt of the Warranty Registration Card at the factory, you will be issued a plastic Owner Warranty Registration Card which is your only valid registration identification. It must be presented to the servicing dealer should warranty service be required. Warranty claims will not be accepted without presentation of this card.
- A temporary Owner Warranty Registration Card will be presented to you when you purchase the product. It is valid only for 30 days from date of sale while your plastic Owner Warranty Registration Card is being processed. Should your product need service during this period, present the temporary registration card to the dealer. He will attach it to your warranty claim form.
- Because of your selling dealer's continuing personal interest in your satisfaction, the product should be returned to him for warranty service.
- If your plastic card is not received within 30 days from date of new product sale, please contact your selling dealer.
- The product warranty is not effective until the product is registered at the factory.
- NOTICE: Registration lists must be maintained by factory and dealer on marine products sold in the United States, should notification under the Federal Boat Safety Act be required.

International Owner Registration

OUTSIDE THE UNITED STATES AND CANADA

- It is important that your selling dealer fills out the Warranty Registration Card completely and mails it to the distributor or Marine Power Service Center responsible for administering the warranty registration/claim program for your area.
- The Warranty Registration Card identifies your name and address, product model and serial number(s), date of sale, type of use and the selling distributor's/dealer's code number, name and address. The distributor/dealer also certifies that you are the original purchaser and user of the product.
- A copy of the Warranty Registration Card, designated as the "Purchaser's Copy", MUST be given to you immediately after the card has been completely filled out by the selling distributor/dealer. This card represents your factory registration identification, and should be retained by you for future use when required. Should you ever require warranty service on this product, your dealer may ask you for the Warranty Registration Card to verify date of purchase and to use the information on the card to prepare the warranty claim form (s).
- In some countries, the Marine Power Service Center will issue you a permanent (plastic) Warranty Registration Card within 30 days after receiving the "Factory Copy" of the Warranty Registration Card from your distributor/dealer. If you receive a plastic Warranty Registration Card, you may discard the "Purchaser's Copy" that you received from the distributor/dealer when you purchased the product. Ask your distributor/dealer if this plastic card program applies to you.
- For further information concerning the Warranty Registration Card and its relationship to Warranty Claim processing, refer to the "International Warranty". Refer to "Table of Contents".

IMPORTANT: Registration lists must be maintained by the factory and dealer in some countries by law. It is our desire to have ALL products registered at the factory should it ever be necessary to contact you. Make sure your dealer/distributor fills out the warranty registration card immediately and sends the factory copy to the Marine Power International Service Center for your area.

Warranty Policies

MerCruiser Limited Warranty - Gasoline Engines

UNITED STATES AND CANADA ONLY

- I. We warrant each new production (not those made for high performance purposes) MerCruiser Stern Drive Power Package, Inboard Engine and accessories attached thereto, (hereafter referred to as "Product") to be free from defects in material and workmanship, but only when the consumer sale is made in the country to which distribution is authorized by us.
- II. This warranty shall become effective only upon our receipt of a completed Warranty Registration Card, which shall identify the Product so registered by serial number. This warranty shall remain in effect for a period of one (1) year from date of purchase.
- III. Since this warranty applies to defects in material and workmanship, it does not apply to normal worn parts, adjustments, tune-ups or to damage caused by: 1) Neglect, lack of maintenance, accident, abnormal operation or improper installation or service; 2) Use of an accessory or part not manufactured or sold by us; 3) Operation with fuels, oils or lubricants which are not suitable for use with the Product; 4) Participating in or preparing for racing or other competitive activity or operating with a racing type lower unit; 5) Alteration or removal of parts; or 6) Water entering engine cylinder/s through the exhaust system or carburetor/s.
- IV. Reasonable access must be provided to the product for warranty service. This warranty will not apply to: 1) Haul-out, launch, towing and storage charges; telephone or rental charges of any type, inconvenience, or loss of time or income; or other consequential damages; or 2) Removal and/or replacement of boat partitions or material because of boat design for necessary access to the Product.
- V. Claim shall be made under this warranty by delivering the Product for inspection to a MerCruiser dealer authorized to service the Purchaser's product. If purchaser cannot deliver Product to such authorized dealer, he may give notice in writing to the Company. We shall then arrange for the inspection and repair, provided such service is covered under this warranty. Purchaser shall pay for all related transportation charges and/or travel time. If the service is not covered by this warranty purchaser shall pay for all related labor and material and any other expenses associated with that service. Any Product or parts shipped by purchaser for inspection or repair must be shipped with transportation charges prepaid. The Warranty Registration Card is the only valid registration identification and must be presented at the time warranty service is required. Warranty claims will not be accepted without presentation of the Warranty Registration Card.
- VI. Our obligation under this Warranty shall be limited to repairing a defective part, or at our option, refunding the purchase price or replacing such part or parts as shall be necessary to remedy any malfunction resulting from defects in material or workmanship as covered by this Warranty. We reserve the right to improve the design of any Product without assuming any obligation to modify any Product previously manufactured.
- VII. All Incidental And/Or Consequential Damages Are Excluded From This Warranty. Warranties Of Merchantability And Fitness Are Excluded From This Warranty. Implied Warranties Are Limited To The Life Of This Warranty. Some States Do Not Allow Limitations On How Long An Implied Warranty Lasts Or The Exclusion Or Limitation Of Incidental Or Consequential Damages, So The Above Limitation Or Exclusions May Not Apply To You.
- VIII. This warranty gives you specific legal rights, and you may also have other legal rights which vary from state to state.

MerCruiser International Warranty - Gasoline Engines

OUTSIDE THE UNITED STATES AND CANADA

- I.** We warrant each new production (not those made for high performance purposes) MerCruiser Stern Drive Power Package, Inboard Engine and accessories attached thereto, (hereafter referred to as "Product") to be free from defects in material and workmanship, but only when the consumer sale is made in the country to which distribution is authorized by us. This warranty shall remain in effect for a period of one (1) year from date of purchase.
- II.** Since this warranty applies to defects in material and workmanship, it does not apply to normal worn parts, adjustments, tune-ups or to damage caused by: 1) Neglect, lack of maintenance, accident, abnormal operation or improper installation or service; 2) Use of an accessory or part not manufactured or sold by us: 3) Operation with fuels, oils or lubricants which are not suitable for use with the Product: 4) Participating in or preparing for racing or other competitive activity or operating with a racing type lower unit: or 5) Alteration or removal of parts or 6) Water entering engine cylinder/s through exhaust system or carburetor/s.
- III.** Reasonable access must be provided to the Product for warranty service. This warranty will not apply to: 1) Haul-out, launch, towing and storage charges telephone or rental charges of any type, inconvenience, or loss of time or income or other consequential damages or 2) Removal and/or replacement of boat partitions or material because of boat design for necessary access to the Product.
- IV.** Claim shall be made under this warranty by delivering the Product for inspection to a MerCruiser dealer authorized to service the Product. If purchaser cannot deliver Product to such authorized dealer, he may give notice in writing to the Marine Power Service Center or distributor. The Marine Power Service Center or distributor shall then arrange for the inspection and repair, provided such service is covered under this warranty. Purchaser shall pay for all related transportation charges and/or travel time. If the service is not covered by this warranty purchaser shall pay for all related labor and material, and any other expenses associated with that service. Any Product or parts shipped by purchaser for inspection or repair must be shipped with transportation charges prepaid.
- V.** Purchaser must provide "proof of purchase" and substantiate "date of purchase" by presenting the "Purchaser's Copy" of the "Warranty Registration Card" or the plastic "Warranty Registration Card" to the dealer authorized to service the Product. If either of these items is not available purchaser must provide a copy of the original "Bill of Sale" (Sales Contract) for the Product to be serviced. Warranty claims will not be accepted until adequate "proof of purchase" is presented by purchaser and "date of purchase" has been substantiated.
- VI.** Our obligation under this Warranty shall be limited to repairing a defective part or AT OUR OPTION, refunding the purchase price or replacing such part or parts as shall be necessary to remedy any malfunction resulting from defects in material or workmanship as covered by this Warranty. We reserve the right to improve the design of any Product without assuming any obligation to modify any Product previously manufactured.
- VII.** All Incidental And/Or Consequential Damages Are Excluded From This Warranty Warranties Of Merchantability And Fitness Are Excluded From This Warranty Implied Warranties Are Limited To The Life Of This Warranty Some Countries Do Not Allow Limitations On How Long An Implied Warranty Lasts Or The Exclusion Or Limitation Of Incidental Or Consequential Damages, So The Above Limitation Or Exclusions May Not Apply To You.
- VIII.** This warranty gives you specific legal rights, and you may also have other legal rights which vary from country to country.

MARINE POWER INTERNATIONAL
Division of Brunswick Corporation
Fond du Lac, Wisconsin 54935 U.S.A.

3 Year Limited Warranty Against Corrosion Failure

(Applicable in the United States, Canada and Australia)

- I. We warrant parts and assemblies of each 1988 and newer production MerCruiser (Product) sold with a one year limited Product warranty or the Bravo and TRS Drive Units on performance Products that have a 90 day limited warranty rendered inoperative as a direct result of corrosion, provided the following simple precautionary steps which are specified in Owner's Manuals have been taken:
 1. Specified maintenance procedures (such as replacement of sacrificial anodes, specified lubrication and touch-up of nicks and scratches) have been implemented on a timely basis.
 2. Recommended corrosion prevention devices have been employed (details below).
- II. This warranty shall become effective upon receipt of a completed standard Product warranty registration card and shall remain effective for a period of three years from the date of purchase.
- III. This warranty does not cover: (1) electrical system corrosion; (2) corrosion resulting from damage, abuse or improper service; (3) corrosion to accessories, instruments, steering systems; (4) damage due to marine growth; (5) Product sold with less than a one year limited Product warranty except for Bravo and TRS Drive Units; nor (6) Product used in commercial application.
- IV. All Incidental And/Or Consequential Damages Are Excluded From This Warranty. Warranties Of Merchantability And Fitness Are Excluded From This Warranty. Implied Warranties Are Limited To The Life Of This Warranty. Some States (Or Countries) Do Not Allow Limitations On How Long An Implied Warranty Lasts Or The Exclusion Or Limitation Of Incidental Or Consequential Damages, So The Above Limitation Or Exclusion May Not Apply To You.
- V. This warranty gives you specific legal rights, and you may also have other legal rights which vary from state to state (or country to country).
- VI. Other details of this warranty are contained in paragraphs IV, V and VI of the (United States and Canada) Product Warranty, and paragraphs III, IV, V and VI of the (International) Product Warranty, contained in this manual, which paragraphs are incorporated herein by reference.

Mercury Marine products are built using the most advanced corrosion protection process available. This manufacturing system, complemented by dealer and customer participation in an anti-corrosion preventive maintenance program, provides protection against repair costs incurred by the effects of marine corrosion.

OWNER'S RESPONSIBILITY

Protection against certain types of corrosion damage must be provided by using such systems as the Quicksilver MerCathode System and/or Galvanic Isolator. These certain types of corrosion damage are: damage due to stray electrical currents (on-shore power connections, nearby boats, submerged metal), or improper application of copper base anti-fouling paint.

If anti-fouling protection is required, Tri-Butyl-Tin-Adipate (TBTA) base antifouling paints are recommended on MerCruiser boating applications. In areas where Tri-Butyl-Tin-Adipate base paints are prohibited by law, copper base paints can be used on the boat hull and transom. Do not apply paint to the MerCruiser drive unit or transom assembly. In addition, care must be taken to avoid an electrical interconnection between the MerCruiser Product and the paint. Corrosion damage that results from the improper application of copper base paint will not be covered by this limited warranty.

TRANSFER OF WARRANTY

This Limited Warranty is transferable to subsequent purchasers for the remainder of the unused portion of the 3-year limited warranty.

Warranty Coverage

The purpose of this section is to help eliminate some of the more common misunderstandings regarding warranty coverage. The table explains some of the types of services that are not covered by warranty.

Keep in mind that warranty covers repairs that are needed within the warranty period because of defects in material and workmanship. Installation errors, accidents, normal wear, and a variety of other causes that affect the product are not covered.

Warranty is limited to defects in material or workmanship, but only when the consumer sale is made in the country to which distribution is authorized by us.

Should you have any questions concerning warranty coverage, contact your authorized dealer. They will be pleased to answer any questions that you may have.

Warranty Does Not Apply To The Following:

- Minor adjustments and tune-ups, including checking, cleaning or adjusting spark plugs, ignition components, carburetor settings, filters, belts, controls, and checking lubrication made in connection with normal services.
- Damage caused by neglect, lack of maintenance, accident, abnormal operation or improper installation or service, or freezing temperatures.
- Haul-out, launch, towing charges; removal and/or replacement of boat partitions or material because of boat design for necessary access to the product; all related transportation charges and/or travel time, etc. Reasonable access must be provided to the product for warranty service. Customer must deliver product to an Authorized Dealer.
- Additional service work requested by customer other than that necessary to satisfy the warranty obligation.
- Labor performed by other than an Authorized Dealer may be covered only under following circumstances: When performed on emergency basis (providing there are no Authorized Dealers in area who can perform the work required or have no facilities to haul out, etc., and prior factory approval has been given to have the work performed at this facility).
- All incidental and/or consequential damages (storage charges, telephone or rental charges of any type, inconvenience or loss of time or income) are the owner's responsibility.
- Use of other than Quicksilver replacement parts when making warranty repairs.
- Oils, lubricants or fluids changed as a matter of normal maintenance is customer's responsibility unless loss or contamination of same is caused by product failure that would be eligible for warranty consideration.
- Participating in or preparing for racing or other competitive activity.
- Engine noise does not necessarily indicate a serious engine problem. If diagnosis indicates a serious internal engine condition which could result in a failure, condition responsible for noise should be corrected under the warranty.
- Lower unit and/or propeller damage caused by striking a submerged object is considered a marine hazard.
- Water entering the engine via the carburetor or exhaust system or submersion. Also water in the starter motor.
- Starter motors and/or armatures or field coil assembly, which are burned, or where lead is thrown out of commutator because of excess cranking.
- Valve or valve seat grinding required because of wear.
- Failure of any parts caused by lack of cooling water, which results from starting power package out of water, foreign material blocking inlets or power package being mounted too high.
- Use of fuels and lubricants which are not suitable for use with or on the product.
- Our limited warranty does not apply to any damage to our products caused by the installation or use of parts and accessories which are not manufactured or sold by us. Failures which are not related to the use of those parts or accessories, are covered under warranty, if they otherwise meet the terms of the limited warranty for that product.

Transferable Warranty

The product warranty is transferable to a subsequent purchaser, but only for the remainder of the unused portion of the limited warranty. This will not apply to products used for commercial applications.

Direct Sale By Owner

- The second owner can be registered as the new owner and retain the unused portion of the limited warranty by sending the former owner's plastic Owner Warranty Registration Card and a copy of the bill of sale to show proof of ownership. In the United States and Canada, mail to:

Mercury Marine
Attn: Warranty Registration Department
W6250 West Pioneer Road
P.O. Box 1939
Fond du Lac, WI 54936-1939

- A new Owner Warranty Registration Card will be issued with the new owner's name and address. Registration records will be changed on the factory computer registration file.
- There is no charge for this service.

Outside the United States and Canada, please contact the distributor in your country, or the Marine Power International Service Center closest to you, for the transferable warranty procedure that would apply to you.

Q-Guard Product Protection Plan

United States and Canada Only

(Certain performance products, triple engine installations, and commercial applications are excluded)

The Mercury Marine Q-Guard Product Protection Plan provides coverage against unexpected mechanical and electrical breakdowns that may occur beyond the standard limited warranty.

The optional Q-Guard Product Protection Plan is the only Factory Plan available for your engine.

Two, three or four - year term plans can be purchased up to 180 days after the original engine purchase date.

See your participating MerCruiser dealer for complete program details.

Owner Service Assistance

Local Repair Service

Always return your MerCruiser powered boat to your local Authorized Dealer, should the need for service arise. Only he has the factory trained mechanics, knowledge, special tools and equipment and the genuine Quicksilver parts and accessories* to properly service your engine should the need occur. He knows your engine best.

* Quicksilver parts and accessories are engineered and built by Mercury Marine, specifically for MerCruiser® stern drives and inboards.

Service Away From Home

If you are away from your local dealer and the need arises for service, contact the nearest Authorized Dealer. Refer to the Yellow Pages of the telephone directory. If, for any reason, you cannot obtain service, contact the nearest Regional Service Center. Outside the United States and Canada, contact the nearest Marine Power International Service Center.

Parts and Accessories Inquiries

All inquiries concerning Quicksilver replacement parts and accessories should be directed to your local Authorized Dealer. The dealer has the necessary information to order parts and accessories for you should he not have them in stock. Only Authorized Dealers can purchase genuine Quicksilver parts and accessories from the factory. Mercury Marine does not sell to unauthorized dealers or retail customers. When inquiring on parts and accessories, the dealer requires the **motor model** and **serial number(s)** to order the correct parts.

Resolving a Problem

Your satisfaction and goodwill are of primary importance to your dealer and to MerCruiser. Any problems with service, sales, warranty or operation of your MerCruiser power package will be resolved by your dealer. He also is your primary source of information on your boat, power package and trailer. Should there be a misunderstanding, or if your problem has not been resolved to your satisfaction, please follow these steps:

STEP ONE - DISCUSS YOUR PROBLEM WITH ONE OF THE DEALERSHIP MANAGEMENT PERSONNEL.

Misunderstandings or complaints can be quickly resolved by the dealer. If you are unable to obtain satisfaction, contact the dealership's owner.

STEP TWO - IF YOU REQUIRE ADDITIONAL ASSISTANCE TO RESOLVE YOUR CONCERN, CONTACT YOUR NEAREST MERCUISER SERVICE CENTER.

Provide the following important information:

- Your name, address and telephone number.
- The model and serial number(s).
- Your dealer's name and location.
- Date of purchase.
- Present hours of operation.
- Details of problem or complaint.
- Boat make and size.
- Propeller pitch and/or part number.
- Normal use and approximate gross load.

Please bear in mind that Service Centers **resolve all problems through the dealership using the dealer's facilities, equipment and personnel.** This is the reason we request you use the preceding steps in sequence when you have a problem or complaint. Our experience has shown that this is the most expedient and successful procedure to follow to ensure satisfaction to our customers.

FOLLOW STEP THREE ONLY AFTER COMPLETING STEPS ONE AND TWO AND YOUR COMPLAINT HAS NOT BEEN RESOLVED.

STEP THREE -CONTACT CONSUMER AFFAIRS DEPARTMENT

United States:

**MERCUISER
3003 N. Perkins Road
Stillwater, OK 74075-2299
Telephone (405) 743-6515**

Canada:

Contact Nearest Regional Service Center

Other Countries:

**Contact the Nearest
Marine Power International Service Center**

The customer service representatives will review all the facts involved. If they feel some further action can be taken, they will advise the Service Center. They will contact your dealer to bring the problem to a satisfactory conclusion.

ALL SERVICE WORK IS DONE BY THE AUTHORIZED DEALER USING THE DEALER'S FACILITIES. OUR SERVICE CENTERS AND FACTORY DO NOT HAVE FACILITIES TO SERVICE OR REPAIR YOUR PRODUCT.

Service Centers

UNITED STATES

MerCruiser
3003 N. Perkins Road
Stillwater, OK 74075-2299
Telephone (405) 743-6566
Fax (405) 743-6570

CANADA

Mercury Marine
1156 Dundas Highway East
Mississauga, Ontario
L4Y 2C2 Canada
Telephone (905) 270-4481
Fax (905) 270-4510

MEXICO, CENTRAL AMERICA, SOUTH AMERICA, CARIBBEAN

Marine Power International
9350 SW 72nd St. (Sunset Dr.)
Suite 100
Miami, FL 33173
U.S.A.
Telephone (305) 596-9606
Fax (305) 596-3869

EUROPE, MIDDLE EAST, AFRICA

Marine Power Europe, Inc.
Parc Industriel de Petit-Rechain
B-4822 Verviers
Belgium
Telephone (0) (87) 32 • 32 • 11
Fax (32) (87) 31 • 19 • 65

AUSTRALIA, PACIFIC

Marine Power International Pty. Ltd.

P. B. 1420

132-140 Frankston Road

Dandenong, Victoria 3164

Australia

Telephone (61) (3) 791-5822

Fax (61) (3) 791-5880

ASIA

Marine Power International Ltd.

Block 1002 Jalan Bukit Merah #07-08

Redhill Industrial Estate

JTC Flatted Factories

Singapore 0315

Telephone (65) 270-7680

Fax (65) 270-7898

JAPAN

Marine Power International - Japan

No.27-2 Muramatsu Chisaki-Shinden

Shimizu City

Shizuoka Prefecture

Japan 424

Telephone (81) 543/34-2500

Fax (81) 543/34-2022

Customer Service Literature

English language publications are available from:

**Mercury Marine
Attn: Publications Department
W6250 West Pioneer Road
P.O. Box 1939
Fond du Lac, WI 54936-1939**

Outside the United States and Canada, contact the nearest Marine Power International Service Center for further information.

When ordering be sure to:

1. List your product, model, year and serial number(s).
2. Check the literature and quantities you want.
3. Enclose full remittance in check or money order (NO C.O.D.'s).

General Maintenance Parts

Engine Parts

Part	5.7L Bluewater	7.4L Bluewater	8.2L Bluewater
Oil Filter	14957	14957	14957
Spark Plug	33-59571	33-59571	33-59571
Distributor Cap	805759A2	805759A2	805759A2
Ignition Coil	392-805570A2	392-805570A2	392-7803A4
Spark Plug Wire Set	84-816608A61	84-816608A61	84-816608A61
Thermostat	807252--2	807252--2	807252--2
Thermostat Gaskets	27-47510	27-33179--2	27-33179--2
Alternator Belt	57-48120A1	57-48122	57-48122
Power Steering Belt	N/A	N/A	N/A
Sea Water Pump Belt	57-13457T	57-69143T	57-69143T
Water Separating Filter	35-805269--1	35-805269--1	35-805269--1
Quicksilver Motor Oil	92-816096A12	92-816096A12	92-816096A12
Storage Seal	92-86145A12	92-86145A12	92-86145A12
Valvtane Plus	92-17955A12	92-17955A12	92-17955A12
Gasoline Stabilizer for Marine Engines	92-817529A12	92-817529A12	92-817529A12
Fuel System Cleaner	92-17885A12	92-17885A12	92-17885A12
Corrosion Guard Spray	92-815869A12	92-815869A12	92-815869A12

Literature Order Form

Model _____ **Horsepower** _____ **Serial Number** _____ **Year** _____

Service Manual - shows the complete assembly and disassembly of the engine or stern drive.

Parts Manual - shows the exploded view of the engine or stern drive with corresponding part number.

Operation and maintenance manual (Owner's Guide) - explains basic operation and maintenance.

Manual	Part Number <small>(Official Use Only)</small>	Qty.	Price Each	Total Price
Service Manual: Engine <input type="checkbox"/>	90-		\$30.00	
Service Manual: Drive <input type="checkbox"/>	90-		\$30.00	
Service Manual: Remote Control <input type="checkbox"/>	90-		\$30.00	
Parts Manual: Engine Only <input type="checkbox"/>	90-		\$4.95	
Parts Manual: Drive Only <input type="checkbox"/>	90-		\$4.95	
Operation and Maintenance Manual <input type="checkbox"/>	90-		\$5.00	
			Sub-Total	
			Sales Tax *	
			Ship/Hand**	
			Grand Total	

* must be collected from customers in all states except:
AK, AZ, DE, HI, ID, IA, ME, MI, MT, NV, NH, NY, OR, VT,
WV, WY

** Orders Totaling: up to \$20.00, add \$3.00
20.01 - \$50.00, add \$4.00
50.01 - up, Free

Please Return with Payment to:

Mercury Marine
Attn: Publications Dept.
P.O. Box 1939
Fond du Lac, WI 54936-1939

Ship To: (Please Print or Type - This is your Shipping Label)

Name _____

Address _____

City _____ State _____ Zip _____

METHOD OF PAYMENT: (NO CASH OR C.O.D.)

Personal Check Cashiers Check Money Order

--	--	--	--	--	--	--	--	--	--	--	--	--	--	--	--

Card Number

Month/Year

/	/
---	---

Expiration Date

Visa Master Card

Signature

_____/_____
Date

()

Telephone Number