

THE INFORMATION CONTAINED HEREIN IS CONFIDENTIAL AND PROPRIETARY TO ALAMARIN-JET OY AND IS NOT TO BE REPRODUCED, MODIFIED OR USED WITHOUT PRIOR PERMISSION OF ALAMARIN-JET OY OR ITS DULY AUTHORIZED REPRESENTATIVE. ALL RIGHTS RESERVED.

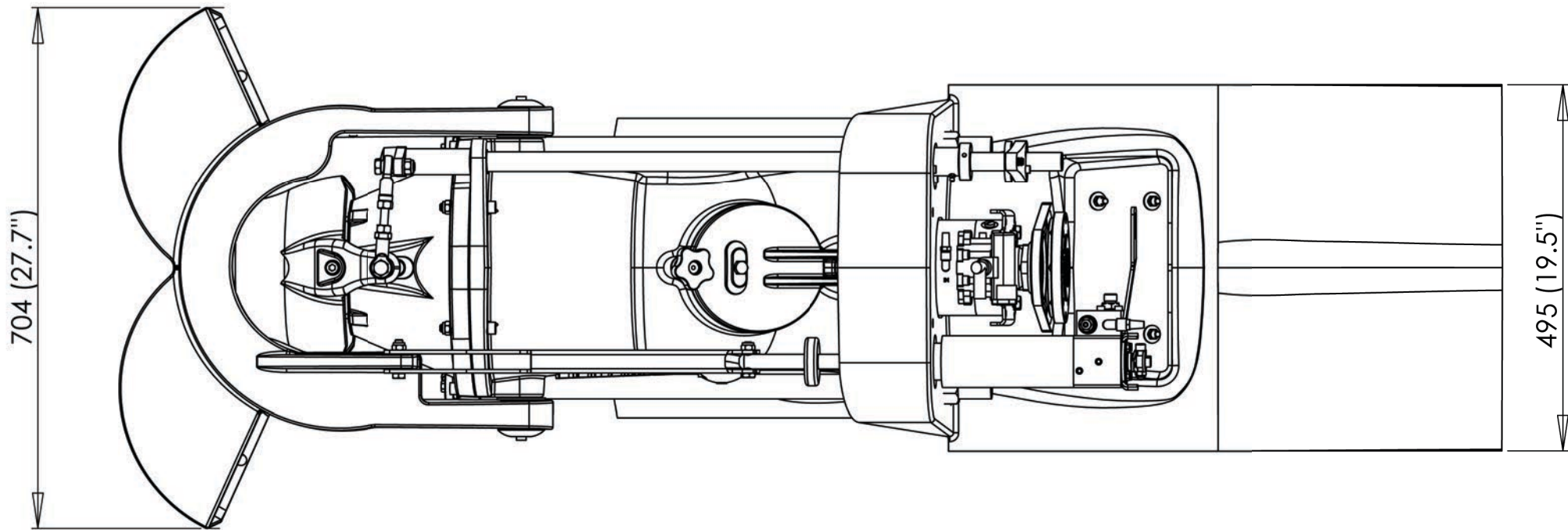
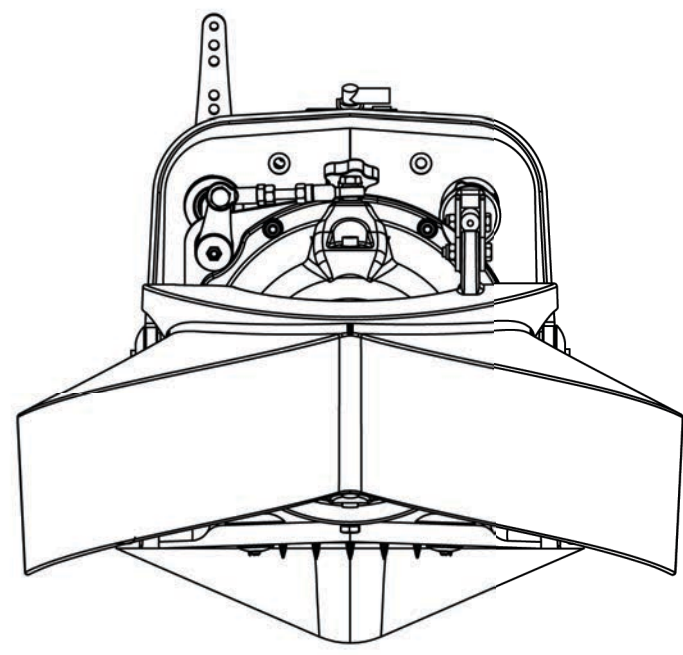
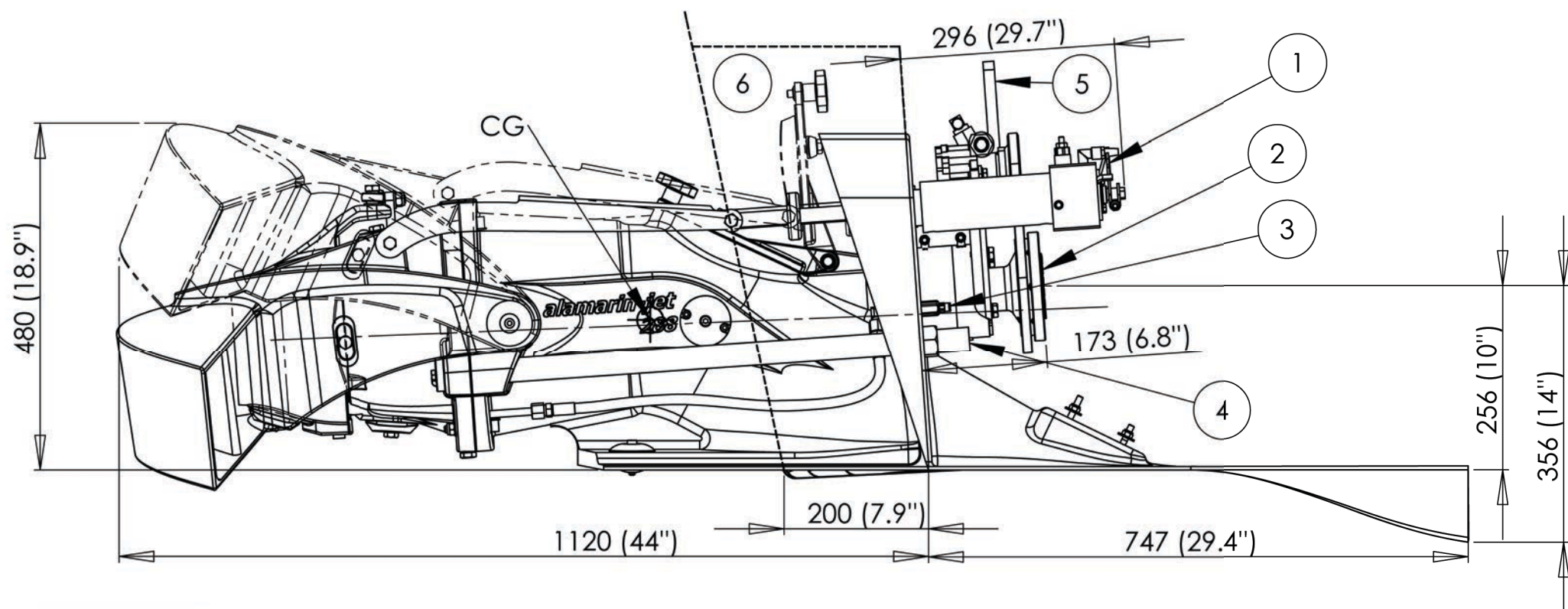

Technical data

Max. power	330kW/450 hp
Max . rpm	3700 1/s
Vessel displacement	5 t (single jet, planing)
Impeller diameter	288mm (11.3")
Unit weight	120kg (265lbs)
Entrained water*	15L (4gal)

*Volume inside the unit within the boat hull (loss of buoyancy)

1. Reverse deflector hydraulic cylinder connection. Standard 33C cable fitting.
2. Input flange DIN-150. Adapter plates available for different intermediate shaft configuration.
3. Rear bearing lubrication with automatic grease feeder.
4. Cooling water intake in both sides. G1" (1" BSP) thread.
5. Steering lever to be connected to steering system. See installation manual for more information.
6. Recess in transom for Jet unit (jet can be partly inserted into the boat hull).

Työpöytäkohtaiset toleranssit: lasituva työstö SFS4011 (ISO2768) keskisarja, hitsatut rakenteet SFS3393 pituusmitat ja kulmat luokka B, muoto ja sijaintitoleranssit DIN8570BL3 luokka E, valukappaleet SFS-ISO8062	Pintakäs. menetelmä - Surf. treatm.	Pinta-ala - Surf. area [m²]	Paino - Weight [kg]	Suun. Design.	
	Sävy - Colour			Piirt. Draw.	
	ISO		Hyväk. Appr.		
	Tuotekoodi Jet-288			Ver.- Rev. B	
	Koko Size A3	Mitta kaava Scale 1:8	Sivu Sheet 1/3		