

Operation and maintenance manual

Go with the flow.

alamarinjet



AJ 285

Table of contents

1. Introduction	1
1.1. Safety precautions	1
1.2. Symbols	1
2. The jet propulsion unit	3
2.1. Structure	3
2.2. Serial number	4
3. Operation	5
3.1. Starting	5
3.2. Steering	6
3.3. Controlling	7
3.3.1. The positions of the reversing deflector control lever	7
3.3.2. Using the reversing deflector	9
3.4. Driving under difficult conditions	9
3.5. Dry running	10
4. Maintenance	11
4.1. Washing	11
4.2. Corrosion protection	11
4.2.1. Changing the anodes	11
4.2.2. Touch-up painting and antifouling	13
4.3. Bearing	14
4.3.1. Lubricating the front bearing	15
4.3.2. Lubrication of the rear end bearing	16
4.4. Control system	18
4.5. Seals	19
4.6. Hydraulic reversing deflector control system	21
4.7. Raw water cooling	24
4.8. Impeller	25
4.8.1. Checking the impeller	25
4.8.2. Removing the impeller	26
4.8.3. Installing the impeller	30
4.9. Intermediate shaft	36
5. Problem situations	39
5.1. Cavitation	39
5.2. Ventilation	40
5.3. Clogged jet	41
Appendix 1. Declaration of incorporation for partially completed machinery	45
Appendix 2. Grease recommendations	46
Appendix 3. Oil recommendations	47
Appendix 4. Tightening torques	48
Appendix 5. Test report	49



WARRANTY TERMS

Warranty for the Alamarin-Jet products is 12 months from the first sea trial. However no longer than 18 months from the date of delivery from our factory.

Alamarin-Jet Warranty covers defects in Alamarin-Jet workmanship and materials for the Warranty period. Alamarin-Jet warranty terms will not cover normal part wear nor following cases with external source of issue: incorrect installation, damage caused by outside affect, vessel overloading, misuse, abnormal wear and tear, accident, improper application, improper transportation or storage, natural calamity, unsuitable water conditions, lack of maintenance or neglecting correct procedures described in Alamarin-Jet manuals.

Any Alamarin-Jet product that is serviced, repaired or altered in any way by anyone other than party certified by Alamarin-Jet will not be covered by the warranty terms. Modifying or repairing Alamarin-Jet products with any other than original Alamarin-Jet parts will lead immediate invalidation of Alamarin-Jet product warranty.

Alamarin-Jet Warranty terms excludes indirect costs: Crane rent, docking, warping, towing, assistance of yard crew and services, loss of profit, travel, hotel charges, daily allowances and waiting time, expenses of unauthorized repair work of Alamarin-Jet products, expenses caused by failure of the jet to other components inside or outside the vessel, damages to any third parties, injuries, or any other inconveniences.

In order for warranty decision, Alamarin-Jet must receive defected parts with comprehensive failure description attached and transportation charges covered by the purchaser to Alamarin-Jet for inspection. Based on given details and inspected product, Alamarin-Jet reserves rights to define whether the case is under warranty. After inspection Alamarin-Jet will provide documented description for the customer regarding the case.

In case replacement parts are needed before Alamarin-Jet has analyzed the returned parts, purchaser buys new replacement parts. After confirming potential warranty decision, Alamarin-Jet will provide credit note covering the parts under warranty. All products and parts removed or replaced under the Warranty shall become property of Alamarin-Jet.

Alamarin-Jet reserves exclusive right for Alamarin-Jet warranty terms and no other person or distributor is authorized to modify this Warranty or give any other Warranty on behalf of Alamarin-Jet.

Alamarin-Jet Oy reserves its right to change, amend, add or delete any of the Terms and Conditions without prior notice. Any disputes are to be settled according to Finnish law by arbitration in Helsinki, Finland according to the rules of the International Chamber of Commerce and in accordance with Finnish legislation of Arbitration.

2017/5/10

GO WITH THE FLOW

1. Introduction

Congratulations on purchasing your new Alamarin-Jet AJ 285 water jet propulsion unit!

This manual contains important information on the operation, use and maintenance of the unit. Please read these instructions carefully before using the unit. This way the unit will be safe to operate.

Please retain this manual for the duration of the product's life cycle. If you lose the manual, contact your nearest distributor for a new one. If you sell the unit, make sure to hand over this manual to the new owner.

Please contact your nearest distributor if you have any queries regarding the operation or maintenance of the unit.

© Alamarin-Jet Oy

Tuomisentie 16
FI-62300 Härmä, Finland
Telephone: +358 10 7745 260
Fax: +358 10 7745 269
Internet: www.alamarinjet.com

All rights reserved.

The information in this manual may not be copied, published or reproduced in any way whatsoever, or exploited for commercial purposes, without express written permission from Alamarin-Jet Oy.

The information in this manual is subject to change without notice. Alamarin-Jet Oy reserves the right to modify the contents without notice.

1.1. Safety precautions

Read these instructions carefully before you operate a boat equipped with the water jet propulsion unit or carry out any maintenance procedures. Please also read the boat's manual. Always follow the instructions and the safety precautions below.









- Only a person with adequate training is permitted to carry out the demanding maintenance procedures described in this manual.
- The person carrying out the procedures must always wear the appropriate protective equipment.
- The work premises must be sufficiently large, safe and well-lit.
- The tools that are to be used must be clean and appropriate for the intended purpose.

1.2. Symbols

Please refer to table 1 for a description of the symbols used in this manual.

Table 1. The symbols used in the manual

Icon	Description
	DANGER Negligence in the performance of a procedure can cause a threat to your life.

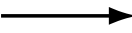
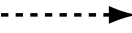
Icon	Description
	WARNING Negligence in the performance of the procedures can lead to personal injury, breakdown of equipment, or serious malfunction of the equipment.
	CAUTION The procedure involves minor danger or a possibility of minor damage to equipment.
	WARRANTY The warranty is voided if the procedure is carried out incorrectly.
	NOTE Important notice or fact.
	TIP Additional information that facilitates the performance of work or a procedure.
	MAINTENANCE ON LAND The boat must be lifted out of the water for maintenance.
	MAINTENANCE IN WATER The maintenance procedure can be carried out in water.
	CARRIED OUT BY ONE PERSON One person can carry out the procedure.
	CARRIED OUT BY TWO PERSONS Two persons must carry out the procedure.
	INDICATOR ARROW
	ARROW DESCRIBING MOTION

Please note that this instruction uses the terms "jet" and "jet propulsion unit". They mainly refer to the same thing.

2. The jet propulsion unit

The Alamarin-Jet water jet propulsion unit (jet) is a single stage mixed flow pump, which produces a high volume flow rate and thrust with high efficiency.

The operation of the unit is based on increasing the water flow rate in the nozzle. The change in the flow rate creates a reactive force in the direction of the flow, which thrusts the boat forward. By changing the direction of the jet flow, the boat can be steered in the desired direction.

The jet gets its propulsion power from a petrol or diesel engine. The most common way to transmit the power is through a gearbox, but a direct drive installation is also possible and functional. The greatest benefits of a gearbox are a real neutral gear and an intake duct backflush. In bobtail installation, it is commendable to use a flywheel adapter provided by the engine manufacturer. This will protect the engine from mechanical damage and corrosion, for example.

2.1. Structure

The jet consists of four main parts (figure 1). These are specified in the table 2.

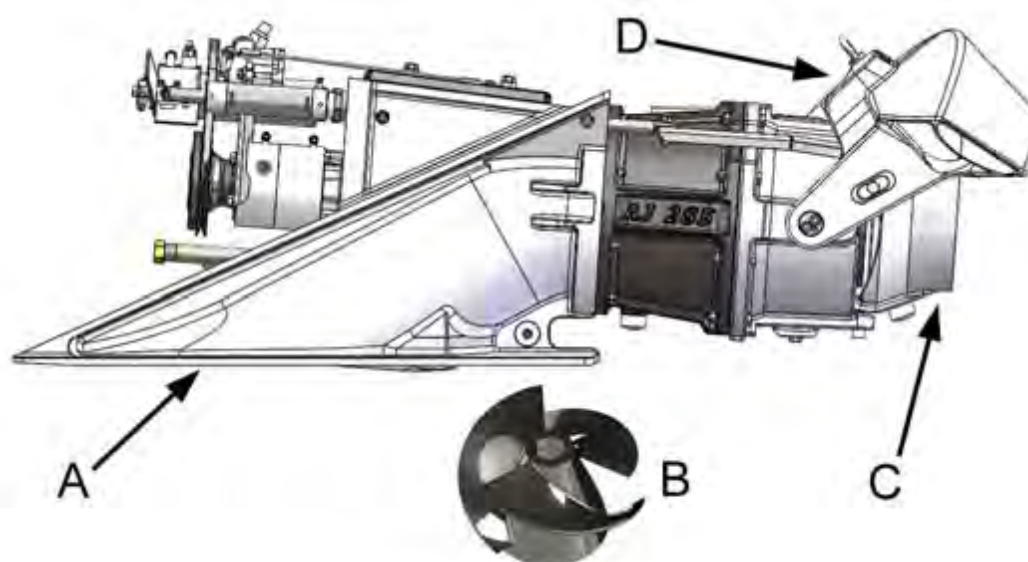

Figure 1. Main parts of the jet

Table 2. Purpose of the main parts of the jet

Part	Purpose
Intake duct (A)	Leads the water from outside the boat to the intake side of the impeller. Keeps the loss of power as small as possible and distributes velocity evenly.
Impeller (B)	Increases the water's flow rate. The impeller is rotated by the driving motor. The nozzle converts the pressure energy produced by the impeller into motion energy.
Steering device (C)	Changes the direction of the jet flow coming out of the nozzle, which creates the force needed for turning.

Part	Purpose
Controlling device (D)	Causes the boat to reverse and stop. Lowering the reversing deflector causes the boat to reverse. The direction of the jet flow changes obliquely forward under the boat, which is when the thrust is directed forward and down.

2.2. Serial number

Every jet has a unique serial number. The serial number has been marked on the type label, which is on the side of the bearing oil reservoir (figure 2). The serial number is also stamped on the frame of the jet under the cooling system (figure 3).



Figure 2. Serial number on the oil reservoir

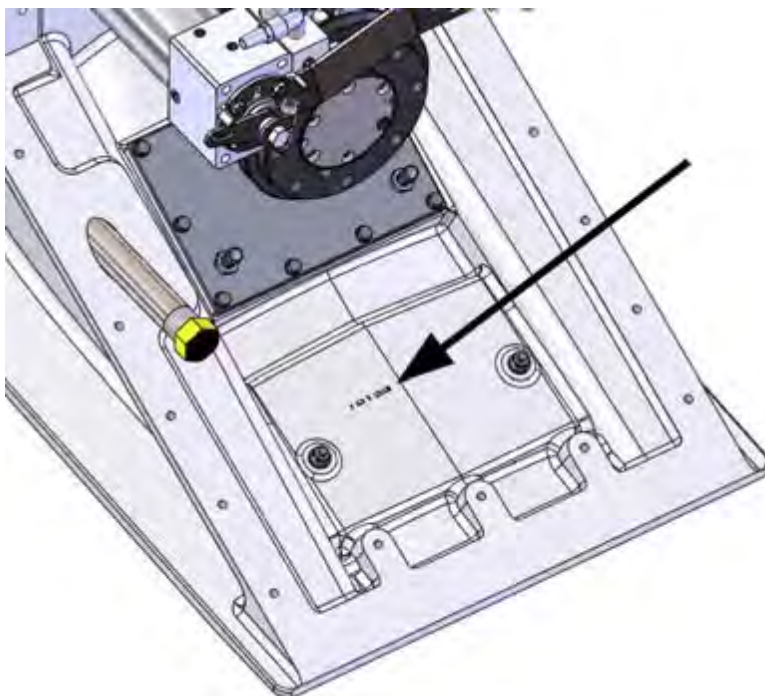

Figure 3. Serial number on the frame

3. Operation

If you have never driven a jet boat before, familiarise yourself with the separate guide "Steering and controlling jet boats" before driving the boat for the first time.

3.1. Starting

Before you start the engine equipped with the jet, make sure that

- the reversing deflector control lever is in centre position
- the gear is disengaged. (If the engine has no gearbox, it must be in the idle position before you start it.)
- Note the direction of the jet's rotation, which usually corresponds to the direction of the engine's rotation (counterclockwise from the rear of the boat). This is why the gear must usually be used in the "reverse" position.

The positions of the reversing deflector control lever are described in section 3.3. *Controlling*, page 7.

Operation for the first time



CAUTION!

Before you set the boat afloat for the first time, make sure that the jet has been installed according to the installation instructions. If you have not personally installed the jet, check with the boat's retailer that the jet has been installed correctly.

Correct installation helps to prevent the emergence of unexpected fault situations which can lead to damages.

The jet does not require separate running in. However, follow the engine manufacturer's instructions about running in during the first few drives. Ensure the functioning of the jet carefully when driving at low speeds.



DANGER!

The jet can be dangerous when running.

Do not go near the rotating parts.

Do not open the jet's inspection hatch when the engine is running.

When running, the jet propulsion unit sprays water backwards at great pressure. Make sure that there is no one in the water behind the boat!

The intake in the bottom of the boat causes suction power at the back of the boat when the jet propulsion unit is running. Make sure that there is no one in the water at risk of being affected by the intake.

When you start the engine for the first time, you may hear a jingling sound for a few minutes. This is normal and the sound will disappear when the impeller

gap sets in place. The noise from the oil pump may be loud at first but it will disappear as the system fills up with oil.

During the first few drives, the reversing deflector's hydraulic control system needs more oil than usual because the hoses and the cooler are empty. Check the oil level and add more oil if necessary in accordance with the instructions in section 4.3.1. *Lubricating the front bearing*, page 15.

**NOTE!**

An oil leak may pollute the environment.

Monitor the oil level and make sure that oil does not leak out.

3.2. Steering

**WARRANTY!**

In this section, controlling the jet boat is described in a way that it is performed using a system that has been installed as intended by the manufacturer.

Alamarin-Jet Oy is not liable for damages which derive from incorrect installation of the system.

Steering denotes exclusively moving the steering nozzle. Steering means changing the boat's bow angle.

The boat is steered by turning the steering wheel. The steering wheel is hydraulically connected to the cylinder, which moves the steering nozzle.

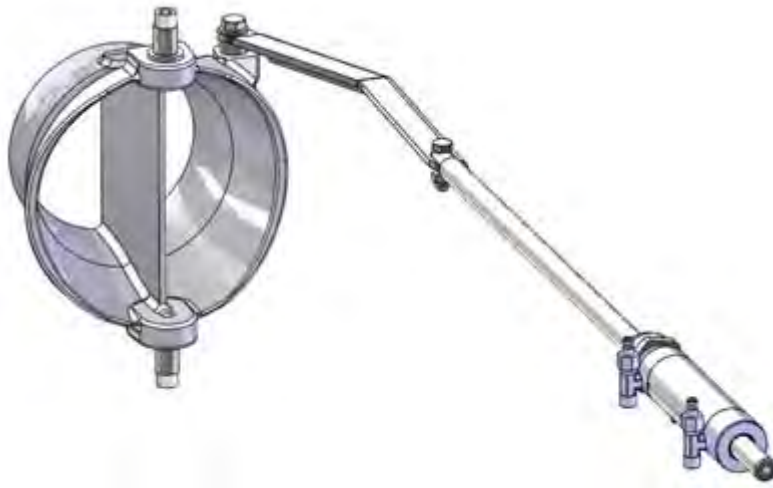

Figure 4. Steering device

Steering is possible only when the power of the jet flow is sufficient. This is why the engine must run on sufficiently high revs when steering. A suitable number of revolutions depends on the engine. Usually it is between 1,000 and 1,500 rpm.

In sharp curves, turning the nozzle causes the boat to slow down. This is normal and increases safety.

Turning the nozzle from one extreme position to the other takes between 1 and 3 revolutions of the steering wheel, depending on the capacity of the steering pump used.



TIP!

When the boat is not in use, it is advisable to turn the wheel all the way to the left. This will protect the cylinder rod and prevent it from collecting dirt, thus increasing the service life of the seals.

3.3. Controlling

Controlling denotes exclusively moving the reversing deflector. Controlling means changing the boat's driving direction (forward–astern). The reversing deflector is moved with the lever, which is usually next to the throttle lever. The lever controls the hydraulic system mechanically (the cable operates the cylinder valve)

The reversing deflector can be lowered in front of the jet flow using hydraulics, causing the boat to reverse (figure 5).

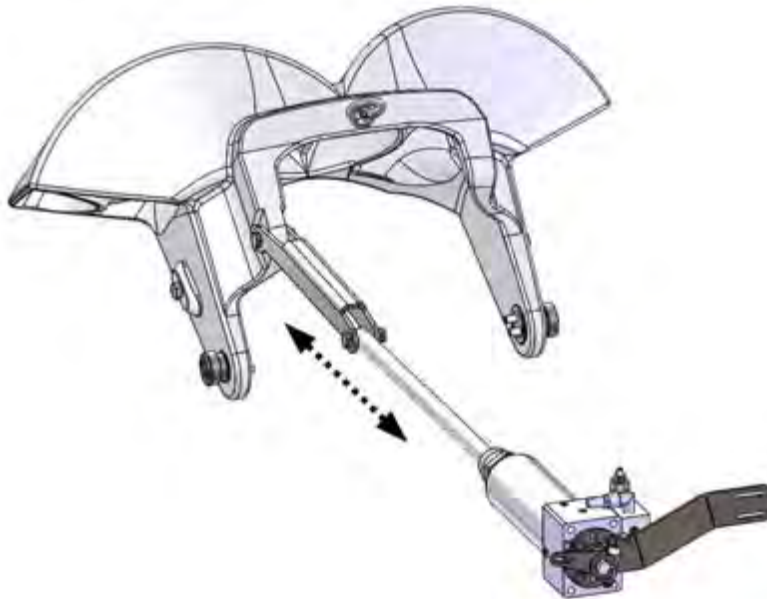

Figure 5. Lowering the reversing deflector

3.3.1. The positions of the reversing deflector control lever

The reversing deflector control lever can be in one of three positions: forward, rear or centre.

Forward position

When the reversing deflector control lever is in the forward position, the deflector is not blocking the jet flow and the boat moves forward (figure 6).

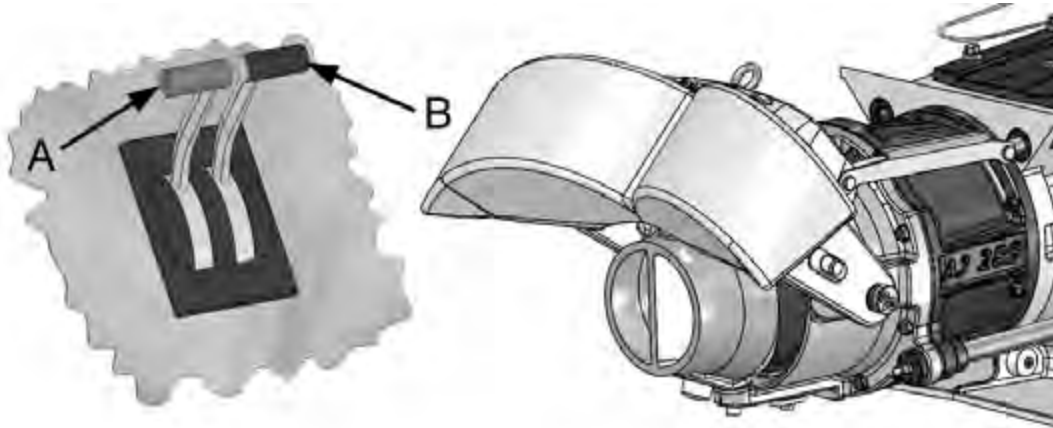
**Figure 6. Ahead**

- A Throttle lever
- B Control lever

Rear position

When the reversing deflector control lever is in the rear position, the deflector is blocking the jet flow and the boat moves astern (figure 7).

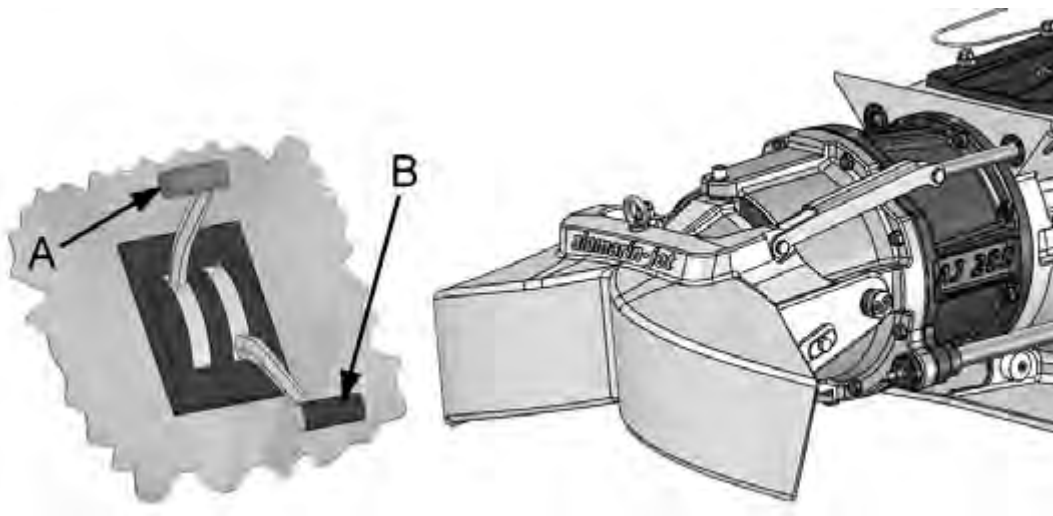
**Figure 7. Astern**

- A Throttle lever
- B Control lever

Centre position

The centre position of the control lever corresponds to the "idle" position of the gearbox: even though the drive is on, the boat does not move. The centre position is not absolute as it depends on the power of the jet flow. You can find the centre position by testing during the first few driving hours.



TIP!

When the boat is not in use, it is advisable to raise the reversing deflector into the upright position. This will protect the cylinder rod and prevent it from collecting dirt, thus increasing the service life of the seals. For long-term storage, you can ensure that the reversing deflector stays in the upright position by tying it from the lifting loop to the stern of the boat.

3.3.2. Using the reversing deflector

When moving at low speeds, the reversing deflector is used to control the boat's speed. Because the engine is being run at 1,000–1,500 rpm to enhance steering, the boat may travel faster than desired. If this is the case, the deflector can be lowered in front of the jet flow to reduce the thrust directed towards the driving direction. This does not affect the steerability, which remains good.

At high speeds, the deflector is not used to reduce speed. Instead, speed is controlled with engine revolutions.

It is possible to turn the boat in place when the deflector is in the centre position. When the nozzle is turned in the desired direction, the boat rotates about its central axis.

When reversing, steering is inversed in comparison to driving forward. If you want to reverse the boat to the left, you must turn the steering wheel to the right. A good rule to remember is that the boat's bow always turns in the same direction as the wheel when reversing. When fast turns are needed, the engine revolutions are not reduced. Instead, the turn is performed through the combined motion of the nozzle and the deflector.

Emergency stop

When the boat is running forwards at great speed, it is possible to stop the boat by only using the reversing deflector. When the reversing deflector is lowered quickly, the boat stops in a very short distance. The emergency stop is to be used in emergencies only.



WARNING!

Alert the passengers and tell them to hold on to something if you are planning an emergency stop. Without being prepared, a passenger may be thrown overboard.

3.4. Driving under difficult conditions

Shallow water

The jet boat can be used in very shallow water. However, note that especially on high revolutions, the suction power of the intake is high (figure 8).



Figure 8. Suction power of the intake

Loose objects may get sucked into the grass rake and small objects may wash through the jet. Stones may cause damage to the jet and its parts. In sandy conditions, the impeller inevitably wears. A worn impeller requires maintenance (section 4.8. *Impeller*, page 25).

Reed fields

At planing speeds, a jet boat usually crosses reed fields without difficulty. In difficult conditions, however, clogging may be possible.

A clogged jet must be cleaned immediately (section 5.3. *Clogged jet*, page 41).

3.5. Dry running

The jet may be run by the engine even out of the water, because the bearings are greased and oiled. This is a significant benefit in comparison to water-lubricated bearings, which do not sustain dry running well.

During dry runs, a temporary water inlet must be arranged for the motor sea water cycle to cool the engine.

4. Maintenance

The jet is designed and manufactured to be as simple as possible. This is why the need for maintenance is low and maintenance can be carried out on shore. However, maintenance must be performed regularly and whenever the need arises.

Alamarin-Jet can provide you with a toolkit, available through separate order, for maintenance purposes. The toolkit includes the tools needed to perform most maintenance and repair procedures on the jet. The tools included in the toolkit are specified in table 3.

Table 3. Toolkit

Tool	Pcs	Size
Wrench	5	10 (0.39"), 13 (0.51"), 17 (0.67"), 19 (0.74") mm
Allen wrench	4	5 (0.20"), 6 (0.24"), 8 (0.31"), 10 (0.39") mm
Knife	1	-
Universal pliers	1	-
Feeler gauge	1	-

4.1. Washing



Washing the jet regularly removes possible salt accruals and impurities, thus reducing the risk of corrosion.

Every time you lift the jet out of the water, it is a good idea to rinse it with fresh water.

4.2. Corrosion protection

The jet has been protected against corrosion in the manufacturing and installation phases. However, the protection requires regular maintenance.

4.2.1. Changing the anodes



The main raw materials used for manufacturing the jet parts are aluminium, acid-proof steel and plastic. Materials that have different electrochemical properties can form a galvanic couple when they are submerged in electrolytic fluid (salt water). A galvanic couple forms an electrical circuit because the materials have different inherent voltages. This in turn leads to electron movement and corrosion of the weaker material.

Cathodic protection is used to prevent the propagation of galvanic corrosion. Cathodic protection means introducing a third material with weaker electrochemical properties into the same circuit.

The jet is protected from galvanic corrosion with passive cathodic protection, i.e. with anodes. Every critical aluminium casting has its own anode. The locations of the anodes are shown in figure 9.

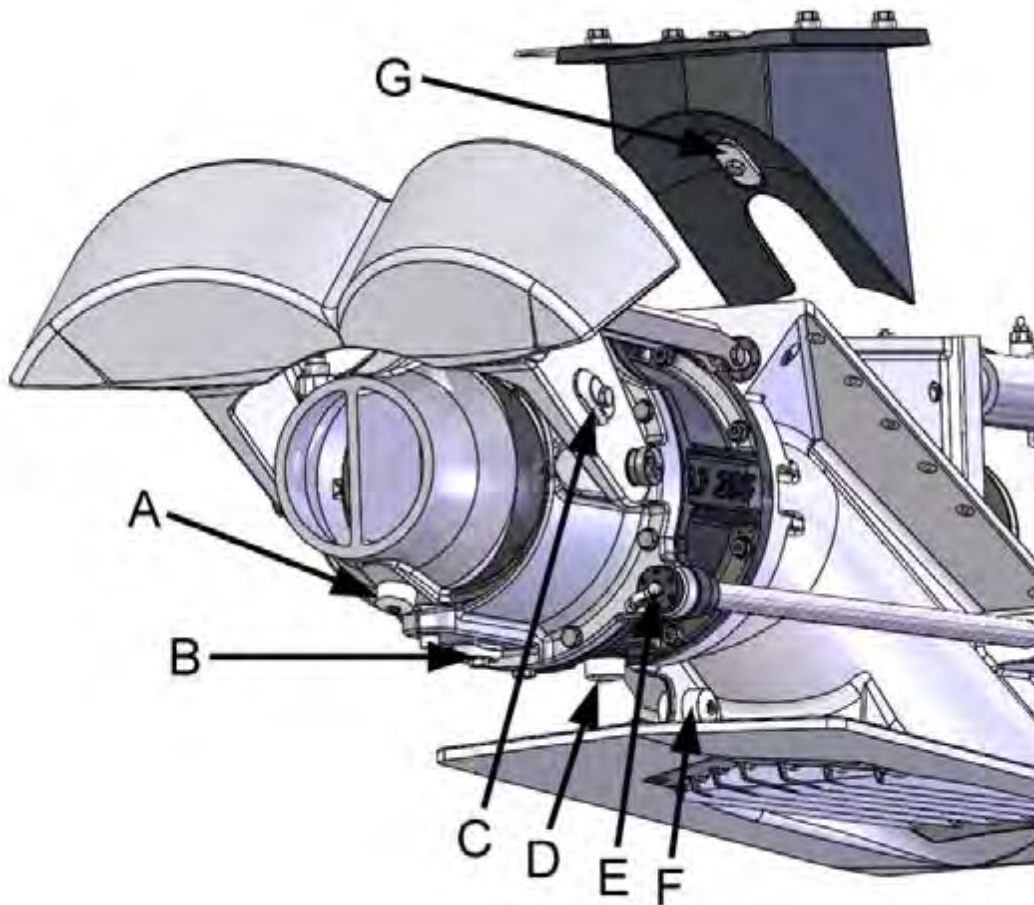

Figure 9. Anodes

- A Steering nozzle (1 pc)
- B Stator (1 pc)
- C Reversing deflector (2 pcs)
- D Impeller tunnel (1 pc)
- E Stator, inside (1 pc)
- F Frame (2 pcs)
- G Inspection hatch (1 pc)

The functioning of the anodes is absolutely crucial to prevent corrosion. The anodes must be replaced when they have worn down to half their original size.

Replacing the anodes:

Most of the anodes are attached with simple screws. Below you will find instructions for changing the anodes that are attached differently.

Replacing the stator anode

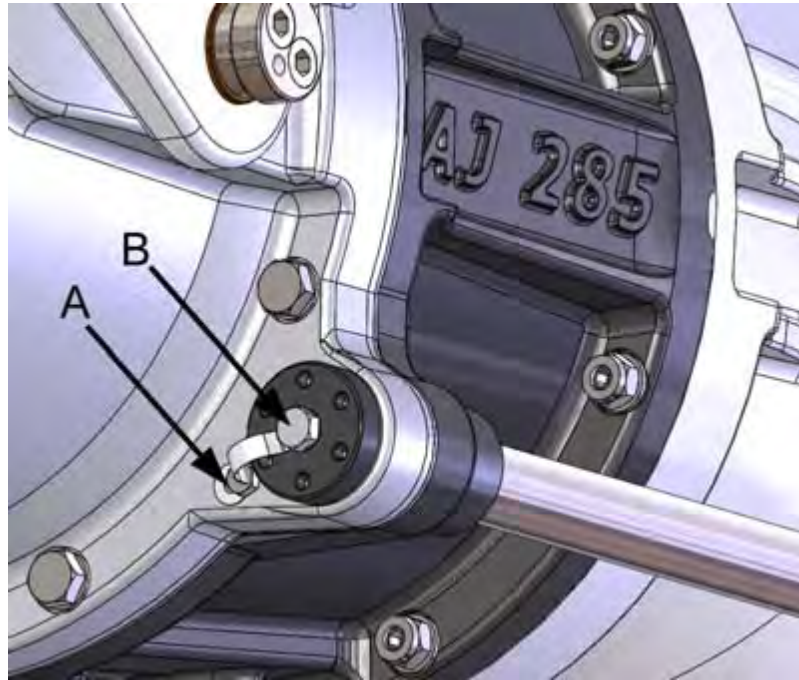

Figure 10. Stator anode

The stator is protected by an anode housed under a plastic plug located on the starboard side the stator. To remove the anode, first open the arrester screw (figure 10, point A) and unscrew the plug. Now you can replace the anode located inside the plug. Leave the screw that holds the anode in place (figure 10, point B) loose and fasten the plug into place using a sealing compound (such as Sikaflex 221). Only then attach the other end of the arrester to the stator. After this, tighten the screw that holds the anode in place.

4.2.2. Touch-up painting and antifouling



The aluminium castings have been protected with paint. Painting efficiently prevents the propagation of various forms of corrosion, e.g. pit corrosion.

Bare aluminium, on the other hand, is liable to corrosion in difficult conditions. This is why it is important to carry out touch-up painting if paint comes loose and aluminium is exposed. Touch-up painting can be done in various ways. What is important is that the paints used are suitable for aluminium and that the paint manufacturer's instructions are followed during painting.

If the boat is going to be used in waterways where the growth and sticking of organisms around the boat's bottom and the propulsion unit is heavy, the propulsion unit can be painted with antifouling paint after installation. Generally speaking, antifouling paints are based on various soluble substances, such as copper. Because the propulsion unit is made mainly of aluminium, copper forms a highly unfavourable galvanic couple with the propulsion unit. In other words, the aluminium starts to corrode because it functions as an anode.



WARNING!

Familiarise yourself with antifouling before painting the propulsion unit with antifouling paint! Painting the propulsion unit with antifouling paint that contains copper will result in heavy corrosion and destruction of the propulsion unit. Do not use any other antifouling paints for painting the propulsion unit except those intended for aluminium surfaces.

A boat bottom made of reinforced plastic can be painted using antifouling paint that contains copper. In this case, leave a 50 mm (2") unpainted area around the propulsion unit in the stern and on the bottom of the boat (figure 11).

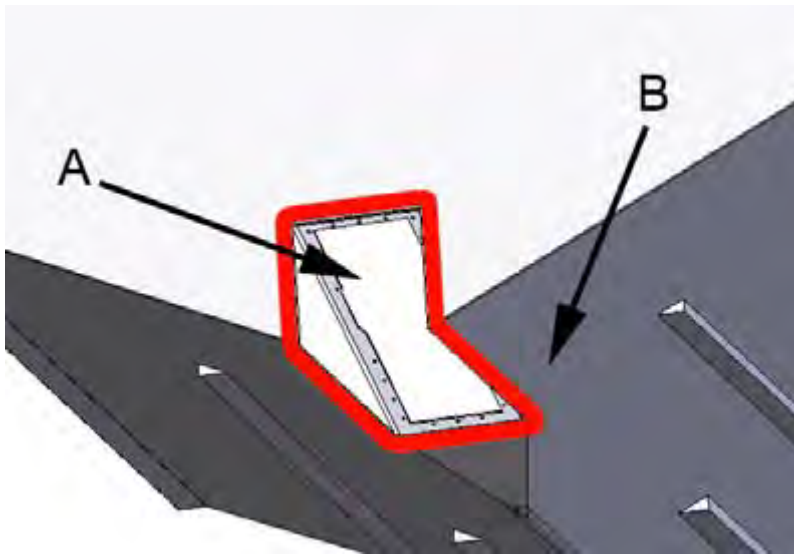

Figure 11. Antifouling

- A Unpainted area
- B Painted area



CAUTION!

Do not paint the anodes or their fastening screws.

4.3. Bearing

The jet's bearing is very simple. There are bearings at both ends of the direct shaft. The structure of the front bearing (figure 12, point A) is receptive to axial pressure. It also carries the radial loads caused by the weight of the shaft and the parts attached to it. At the rear end, a grease lubricated needle bearing supports the shaft (figure 12, point B). A water-lubricated bushing can also be used.

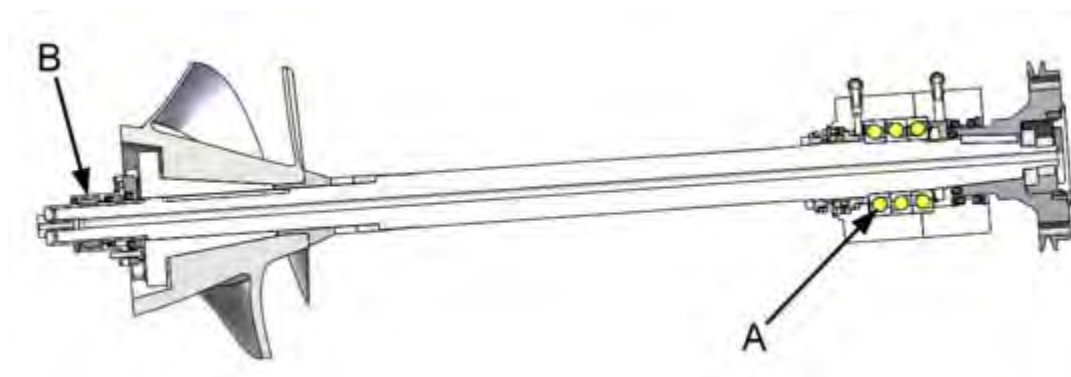

Figure 12. Bearing

4.3.1. Lubricating the front bearing



The front bearing is oil-lubricated and the housing is secured with a mechanical sealing. When the shaft rotates, the oil circulates through the reservoir and impurities gather to the bottom of the reservoir on the drain plug magnet (figure 13, point A).



Figure 13. Drain plug magnet and oil return hose

- A Drain plug magnet
- B Oil reservoir return hose connection

Oil change



WARNING!

Use protective gloves while handling oil.

The front bearing oil must be changed after the first 20 hours of driving and then after every 500 hours or once every driving season.

Before you start changing the oil, make sure you have a container for draining the used oil.

Changing the oil:

1. Open the reservoir cap and stir the oil inside.

Impurities are easier to remove from the reservoir when they are mixed in with the oil.

2. Open the drain plug (figure 13, point A) and drain the oil into the container.
3. Clean the plug magnet, close the drain plug and fill the reservoir with new oil. Oil recommendations can be found in appendix 3. *Oil recommendations*, page 47.

This prevents air from drifting into the system and ensures that lubrication functions well from the start.

4. Remove the reservoir return hose (figure 13, point B) and keep it below the reservoir.

This way the oil drains out from the bearing housing and the hoses and the system fills up with new oil. The time it takes to drain the oil depends on how far the reservoir is from the bearing housing. The colour of the oil indicates whether all the old oil has drained out. The system can have a maximum volume of up to 1 L, depending on the length of the hoses.

5. Attach the oil return hose to the reservoir once the system is filled with new oil.
6. Check the oil level from the dipstick on the reservoir cap (figure 22, point B).

When the shaft starts to rotate, the system generates pressure into the return line, causing oil to start circulating in the system.

4.3.2. Lubrication of the rear end bearing



The rear end bearing is lubricated from the engine room with petroleum jelly. The external lubrication channel runs from the engine room to the stator, through which the lubricant flows into the rear bearing housing.

An automatic lubrication unit that makes sure that the rear end bearing is lubricated regularly is available as an accessory.

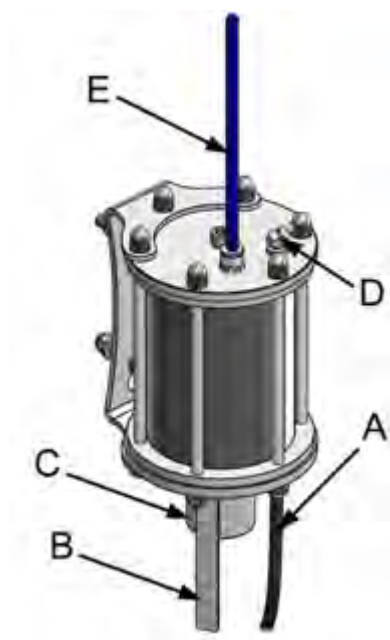

Figure 14. Automatic lubrication unit

A	Oil pressure hose from the hydraulic cylinder	D	Grease nipple
B	Scale	E	Grease hose to the lubrication channel
C	Piston		

Feeding

You can adjust the feed as follows:

- If the automatic lubrication unit feeds too much grease (the reservoir empties too soon), reduce the pressure by loosening the adjusting screw (figure 15).
- If the automatic lubrication unit does not feed grease to the rear bearing (cold conditions, thick grease type), increase the pressure by tightening the adjusting screw (figure 15).

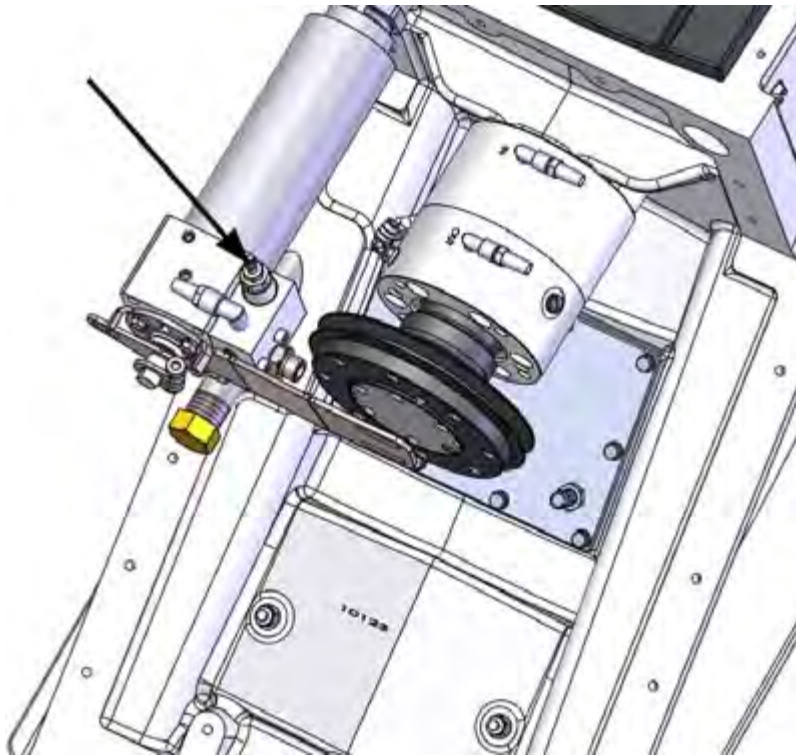

Figure 15. Lubricating the Rear Bearing

The amount of grease fed to the rear bearing must be 0.1 l/100 h (6 cu in/100 h). The grease volume in the unit is 0.3 l (18 cu in). With these settings, the reservoir empties after 300 hours. If you notice that the reservoir empties more quickly or slowly than this, adjust the pressure in the desired direction.

You can fill the reservoir by pushing grease into it with a grease gun through the nipple (figure 14, point D). This will cause the piston to protrude out of the reservoir.

The properties of the grease to use are described in appendix 2. *Grease recommendations*, page 46.



NOTE!

Any excess grease exits the bearing housing into the water.

Only use environmentally friendly grease for lubricating the bearing.

If there is no automatic lubrication unit installed into the system, there is a nipple at the end of the lubrication hose, through which grease can be pumped to the rear bearing. 0.5 dl (6 cu in) of grease should be added every 50 hrs.

4.4. Control system



The joints and shaft bushings that belong to the control systems are essentially maintenance-free, but lubrication prolongs their operating life. Locations

where waterproof petroleum jelly should be added during maintenance are marked in figures 16-17 . When the plastic bearings of the joints wear and gaps are created, they must be replaced.

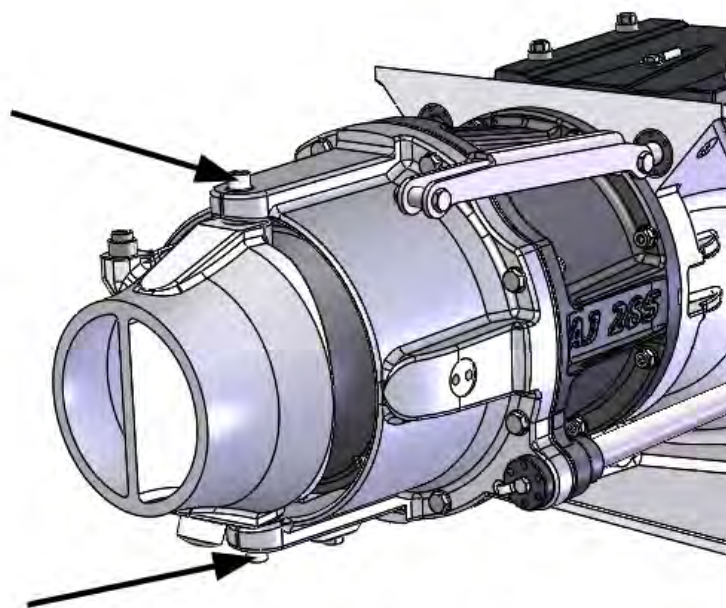

Figure 16. Steering nozzle joints

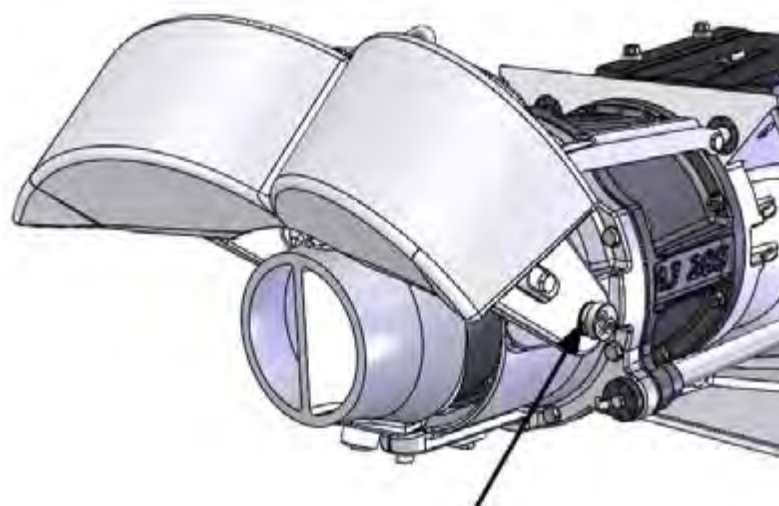

Figure 17. Reversing deflector joints

4.5. Seals



Inspection hatch seal

If the inspection hatch seal leaks, it must be replaced.

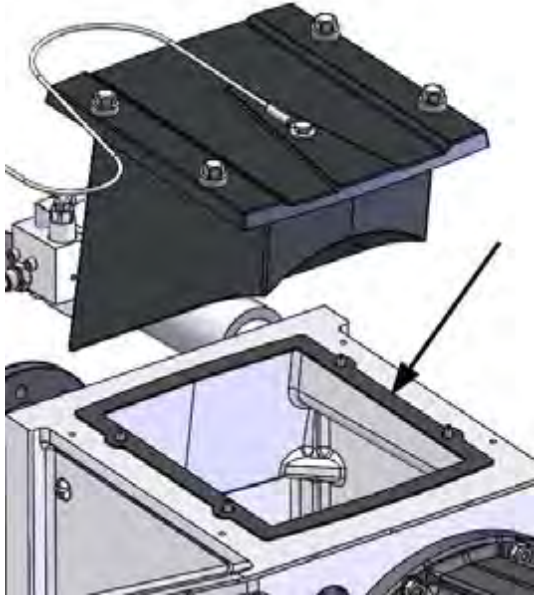

Figure 18. Inspection hatch seal

If the inspection hatch seal leaks, it will cause ventilation or water leakage in the engine room if the inspection hatch is inside the engine room (see section 5.2. *Ventilation*, page 40).

Control rod seals

There are threaded sleeves equipped with seals at the rear ends of the control rods (figure 19). The seals can be replaced without removing the cylinders.

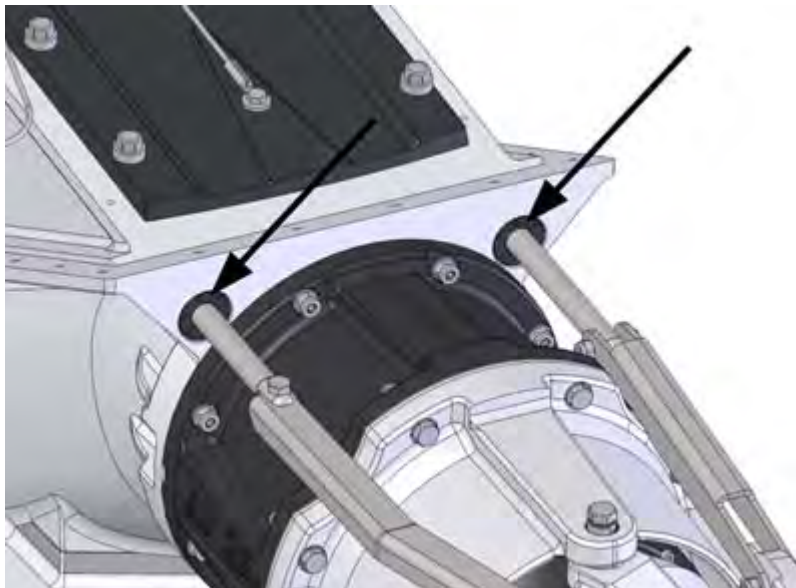

Figure 19. Control rod seals

Replacing the seals:

Unscrew the sleeve by turning it from the holes on the front surface of the sleeve.

We recommend replacing the sleeve along with the seal. Apply some sealing compound to the thread and screw the sleeve into place.



CAUTION!

If water gathers in the bilge, the cause for this must be determined immediately. Any possible leaks must be repaired immediately. Water can damage e.g. the starter motor.

4.6. Hydraulic reversing deflector control system

For controlling the reversing deflector, the jet has a hydraulic cylinder which is operated mechanically with a cable. The cable (figure 20, point B) operates the valve regulator (point A). The cylinder gets its power from the pump which has been integrated in the propulsion unit.

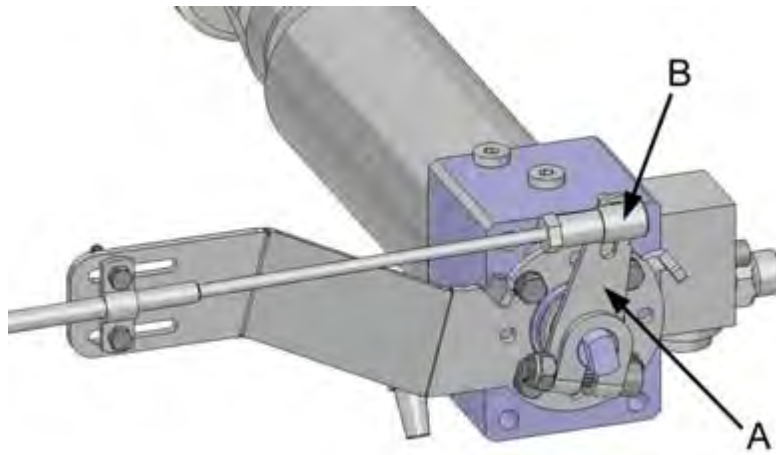

Figure 20. Hydraulic cylinder

In a stock delivery, the system does not include a control lever or a cable, so their type varies depending on the boat manufacturer. However, the different types of systems have the following things in common:

- The operation of the deflector is always separate from the throttle and the gearbox.
- The stroke length of the cylinder is always the same.
- The incoming direction of the cable can be chosen freely.

The oil circulating in the system must be cooled down in order to prevent excessive heating. This is done with a heat exchanger, which is integrated into the frame of the propulsion unit (figure 21).



WARRANTY!

If the oil in the system is not cooled, the manufacturer is not responsible for possible damages which derive directly or indirectly from the oil overheating.

If the valve regulator is removed, the cylinder must be readjusted. The adjustment instructions can be found in the Repair manual.

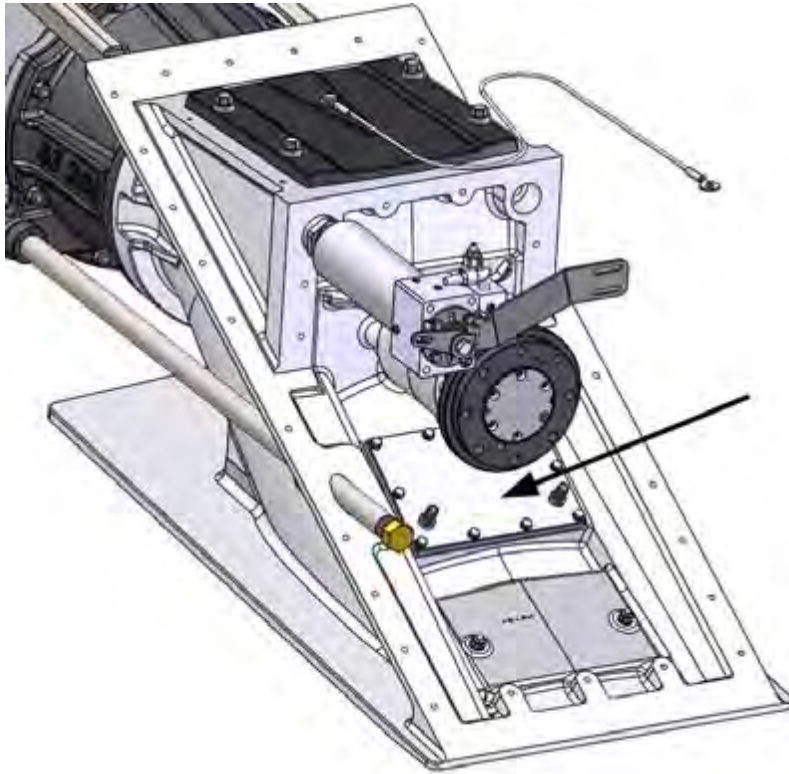

Figure 21. Oil cooler

The system must have the right amount of oil. If it is necessary to add oil to the system, add it through the oil reservoir cap (figure 22, point C). There is a dipstick on the reservoir cap with markings for maximum and minimum oil levels (figure 22).



Figure 22. Checking the oil level

- A Maximum level
- B Minimum level
- C Cap

Note that the oil must be changed once every driving season. The type of oil to use is described in appendix 3. *Oil recommendations*, page 47.

Amount of oil in the hydraulic system and the front bearing

- Hydraulics: 1.3-1.7 L
- Front bearing: 0.9-1.2 L

Replacing the oil filter

The oil filter in the oil reservoir must be replaced after every 500 operating hours.

1. Open the six cover screws (figure 23)



Figure 23. Oil reservoir cover screws

The filter is located under the cover and has a spring on top of it that keeps the filter in place (figure 24).



Figure 24. Oil filter spring

2. Remove and replace the spring and the filter.

It is not necessary to replace the spring unless it is damaged.

3. Put the cover back into place.

Make sure that the cover seal is correctly positioned in the groove (figure 25, point A). The cover must also be positioned correctly so that the spring is in line with its support (figure 25, point B).

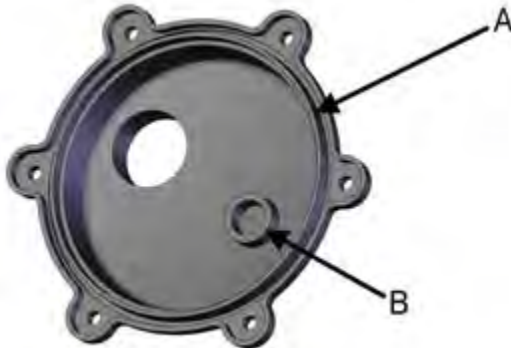

Figure 25. Oil reservoir cover

4. Reattach the six cover screws (figure 23).

4.7. Raw water cooling

Figure 26 shows a system in which the cooling water comes from the jet. The system can consist of different looking components depending on the boat manufacturer. What is essential is the correct order of the components. A system equipped with a separate raw water intake pump has the same main components.

The jet comes complete with the possibility to connect the engine cooling water (figure 26, point 1). The engine does not need a separate water pump. In case the cooling water is taken with a separate pump, the jet's raw water line is stoppered.

At the beginning of the line, there must be a tap with which the line can be shut temporarily, such as during cleaning of the filter or other maintenance. The raw water line requires no other separate maintenance procedures.

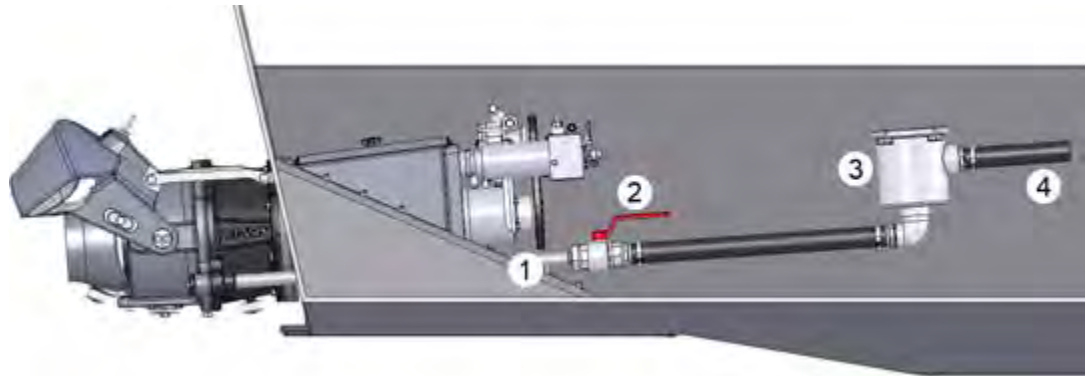

Figure 26. Raw water cooling

- 1 Raw water connector
- 2 Tap
- 3 Filter
- 4 Input for the engine

4.8. Impeller

Depending on driving conditions, the impeller will wear down, causing a gap to develop between the tunnel wall and the tip of the impeller blade. The gap should be as small as possible to achieve maximum efficiency. (The factory installation gap is 0.4 mm (approx. 0.016") when the stator centres the shaft). When the gap expands too much, the jet's performance decreases.

The impeller usually wears on the outer edge of the blades. The impeller operates in a cone-shaped space and its position can be adjusted in the direction of the shaft in accordance with the blade wear.

The longitudinal position of the impeller in the tunnel reveals its power demand. The deeper the impeller sits, the less power it takes from the engine, because the diameter of the impeller is smaller. The pitch and the length and number of blades naturally also affect the power demand.

By adjusting the impeller, its operating life can be prolonged considerably. The adjustment of the impeller should be done whenever it is necessary, but checks must be carried out at least once a year. The impeller is adjusted by removing the impeller and then reinstalling it.

4.8.1. Checking the impeller

The condition of the front edge of the impeller blades is important. A damaged front edge causes cavitation.



WARNING!

The impeller blade edges can be sharp and cut your hands. Protect your hands with protective gloves before you remove the impeller.

The front edge can be repaired by carefully hammering the marks caused by bigger stones and grinding them smooth. The front edge must also be sharpened, not sharp enough to cut, but so that it is no thicker than 1 mm (approx. 0.04").

You can also return the impeller to the factory for checking and repairing.

If you suspect that there is a malfunction in the impeller, do as follows:

1. Shut down the engine and open the inspection hatch.
2. Check that there is no blockage in the intake duct.
3. Check the impeller visually. Notice especially the gap between the outer edge of the blade and the tunnel wall.

If there is no apparent fault, do as follows:

1. Lift the boat out of the water.
2. Remove the impeller (section 4.8.2. *Removing the impeller*, page 26).
3. Check the impeller more closely.

Contact the importer or the manufacturer if necessary and ask for additional instructions.

4.8.2. Removing the impeller



Before the impeller can be removed, the reversing deflector, the steering nozzle and the stator must be removed.

Removing the impeller:

1. Open the screws indicated by arrows in figure 27 .



WARNING!

Make sure that the reversing deflector is not accidentally lowered. This may result in serious injury!

Lower the reversing deflector past the steering nozzle. The steering nozzle must be centred when the reversing deflector is lowered.



WARNING!

The reversing deflector must not be turned by force from the outside while it is connected to a hydraulic cylinder.

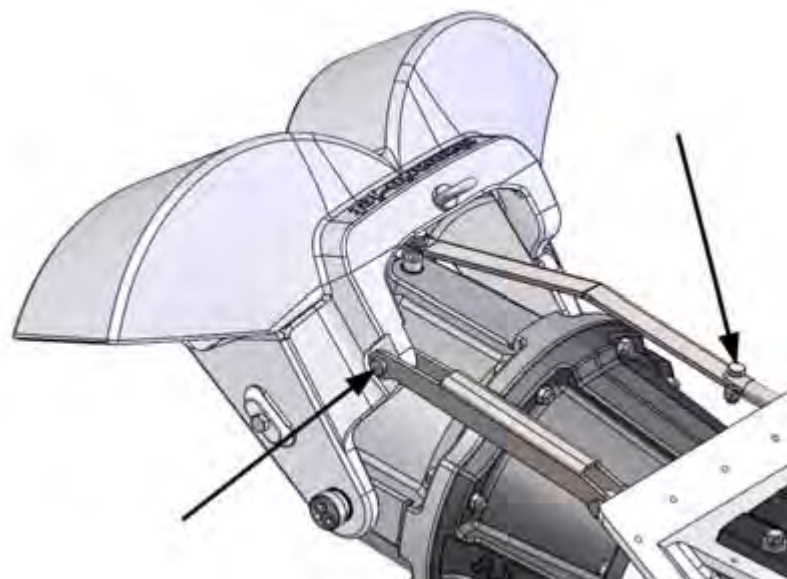

Figure 27. Reversing deflector screws

2. Open the stator's fastening screws (figure 28).

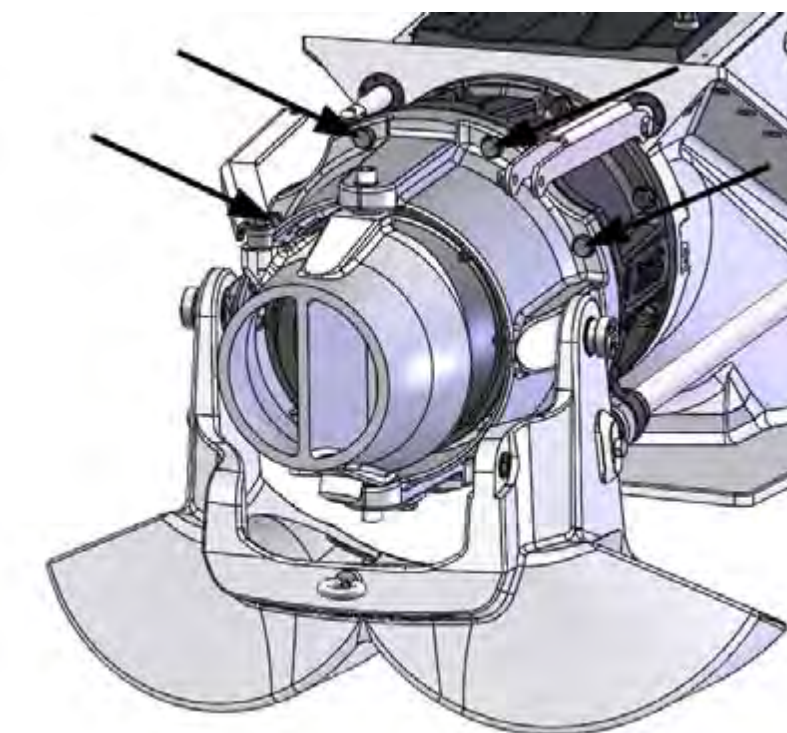

Figure 28. Stator fastening screws

There are eight screws, four of which are shown in the figure.

3. Remove the stator, reversing deflector and steering nozzle as a complete unit (figure 29).

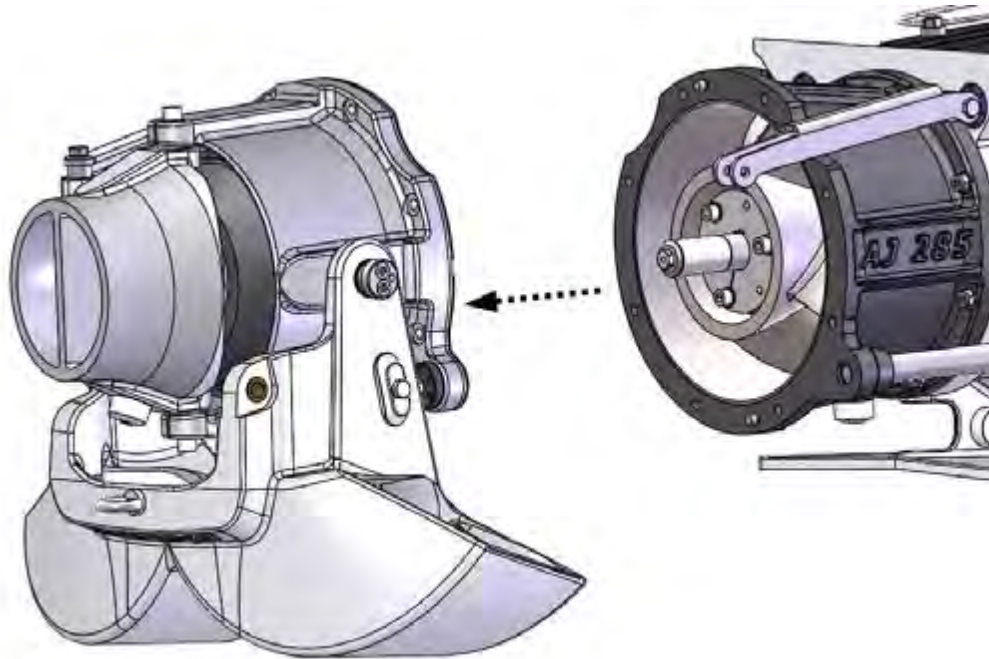

Figure 29. Removing the stator, reversing deflector and steering nozzle

The impeller is connected to the shaft either with a mounting cone or a locking plate attached to the end of the shaft. The impeller connection method depends on the model of the impeller. Instructions for removing the impeller are provided below for both connection methods.

Mounting cone

4. Loosen the impeller fastening screws (figure 30, point A).

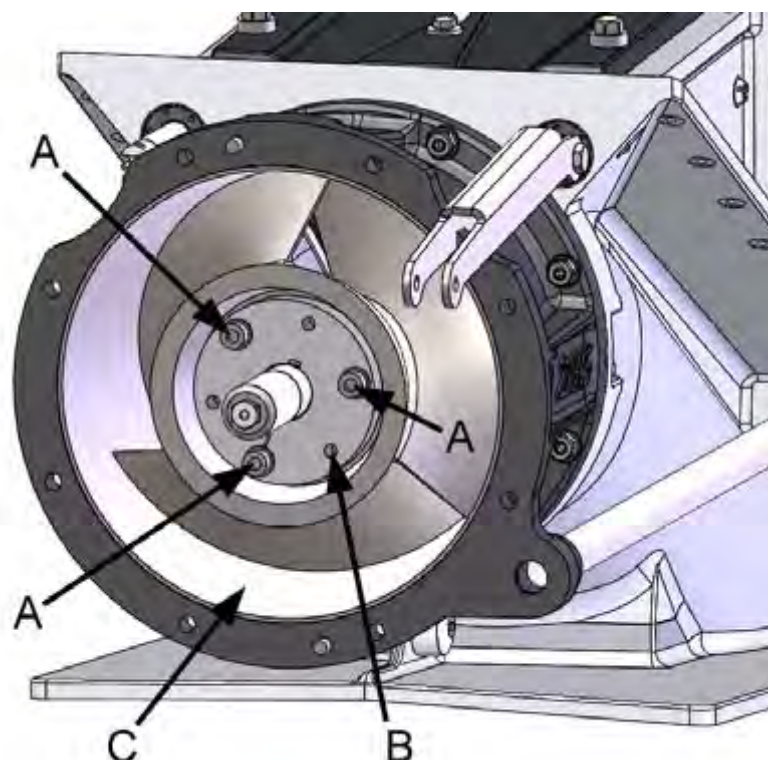

Figure 30. Impeller fastening screws, mounting cone

5. Remove one screw completely and screw it into the threaded hole in the plastic mounting cone (figure 30, point B).

When you tighten the screw in the threaded hole, the mounting cone is released and the impeller can be pulled off the shaft. If the adapter is very tight, use multiple screws to release it.

Locking plate

4. Unscrew the screw located at the end of the shaft (figure 31, point A) and remove the locking plate (figure 31, point B).

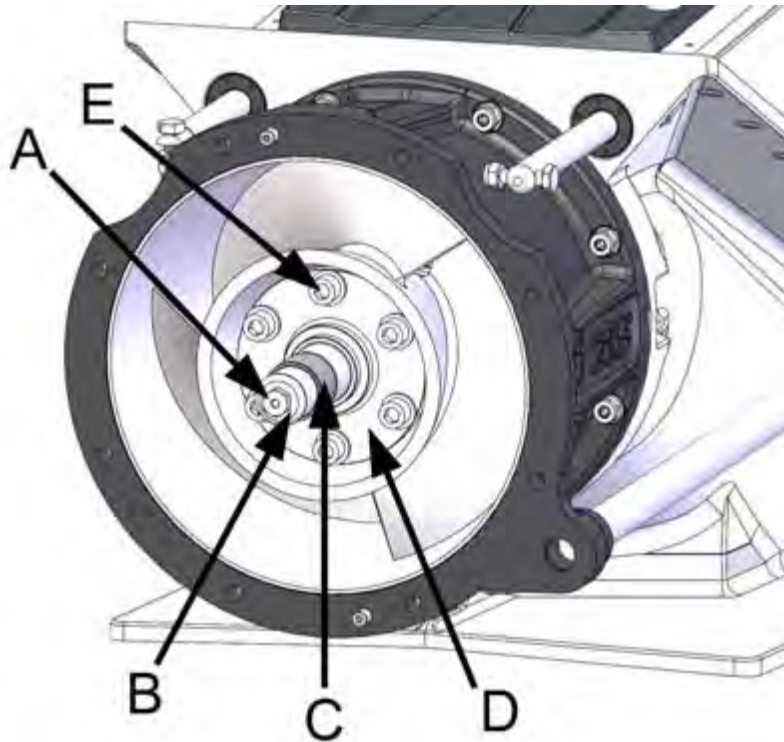

Figure 31. Impeller fastening screws, locking plate

5. Remove the impeller from the shaft together with the sleeve (figure 31, point C), and the mounting flange (figure 31, point D).

4.8.3. Installing the impeller



New and repaired impellers are fitted in the same way.

The impeller is connected to the shaft either with a mounting cone or a locking plate attached to the end of the shaft. The impeller connection method depends on the model of the impeller. Instructions for installing the impeller are provided below for both connection methods.

Installing the impeller with the mounting cone:

1. Attach the plastic mounting cone to the impeller hub and tighten the screws so that they are finger-tight.

Note that the place of the keyway is marked on the impeller hub (figure 32).



Figure 32. Position of the keyway

The thrust caused by the impeller is transmitted through the adjuster sleeve to the shaft (figure 33, point A). The sleeve consists of rings of different thickness. The length of the sleeve can be adjusted in 0.5 mm (approx. 0.02") increments by changing the number of the rings. This way the impeller gap on the outer race becomes fit.

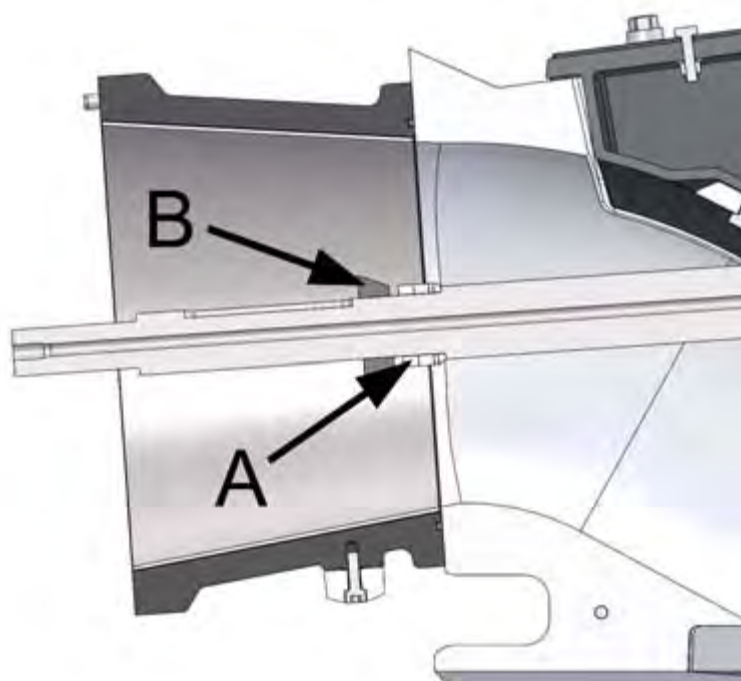

Figure 33. Adjuster sleeve

2. Find the right adjuster sleeve length by testing.
3. Push the sleeve and the plastic insulating ring (figure 33, point B) on to the shaft. The insulating ring sits against the impeller.
4. Place the impeller into the duct and push it against the shim rings.

At this point the screws of the plastic mounting cone must be finger-tight.

5. Measure the gap on the impeller outer race.

If the front surface of the impeller hub does not reach the shim rings, add more shim rings.

The optimal gap is 0.8-1.2 mm (approx. 0.031-0.047") at the upper part of the duct. When you measure the gap, note that the shaft is not centred when the stator is removed, but the shaft's rear end hangs low and the whole gap is visible in the upper part of the duct.



CAUTION!

If the gap is too big, it will cause loss of power and reduce performance.

6. Once you have found the right adjuster sleeve length, place the key in the shaft keyway (figure 34) and push the impeller on to the shaft against the isolation ring.

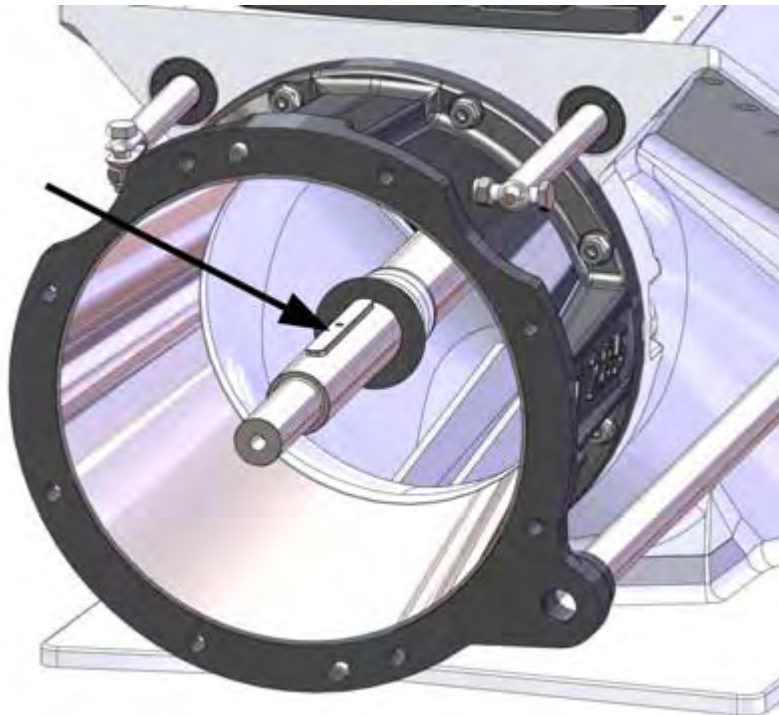

Figure 34. Keyway

7. Tighten the impeller fastening screws evenly in a crosswise sequence.

The tightening torque is 20 Nm.

While tightening, the impeller moves back a bit and a small gap develops on the front. The gap will disappear when the impeller is being loaded.

8. Install the stator and the steering nozzle in place in reverse order to that when removing it (section 4.8.2. *Removing the impeller*, page 26).

The tightening torque of the M10 screws is 46 Nm.

Installing the impeller with the locking plate:

1. If the impeller mounting flange was detached from the impeller, re-attach it.
2. Lubricate the flange seals with waterproof petroleum jelly (such as Shell Gadus S2 V220AC or similar) and push the sleeve into place.

Note the position of the keyway, which is indicated on the impeller hub (figure 32). Apply thread locking compound (such as Loctite 242) to the screws and tighten them to 85 Nm.



Figure 35. Position of the keyway

The thrust caused by the impeller is transmitted through the adjuster sleeve to the shaft (figure 33, point A). The sleeve consists of rings of different thickness. The length of the sleeve can be adjusted in 0.5 mm (approx. 0.02") increments by changing the number of the rings. This way the impeller gap on the outer race becomes fit.

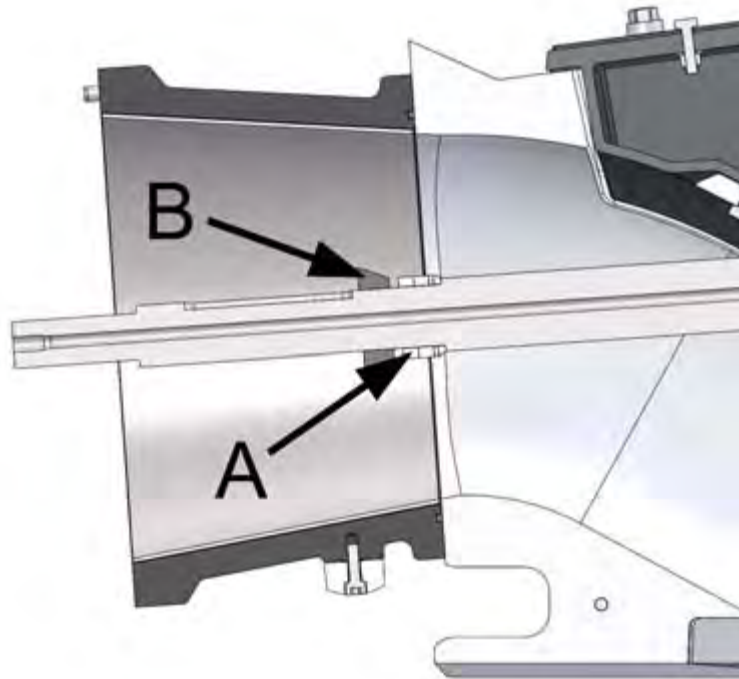

Figure 36. Adjuster sleeve

Find the right sleeve thickness by testing as follows:

3. Lubricate the shaft and the inner surface of the impeller mounting flange with waterproof petroleum jelly (such as Shell Gadus S2 V220AC or similar).
4. Place the impeller into the duct and push it against the shim rings.
5. Measure the gap on the impeller outer race.

If the front surface of the impeller hub does not reach the shim rings, add more shim rings.

The optimal gap is 0.8-1.2 mm (approx. 0.031-0.047") at the upper part of the duct. When you measure the gap, note that the shaft is not centred when the stator is removed, but the shaft's rear end hangs low and the whole gap is visible in the upper part of the duct.



CAUTION!

If the gap is too big, it will cause loss of power and reduce performance.

6. Once you have found the right adjuster sleeve length, place the key lubricated with waterproof petroleum jelly (such as Shell Gadus S2 V220AC or similar) in the shaft keyway (figure 34) and push the impeller onto the shaft against the adjuster sleeve.

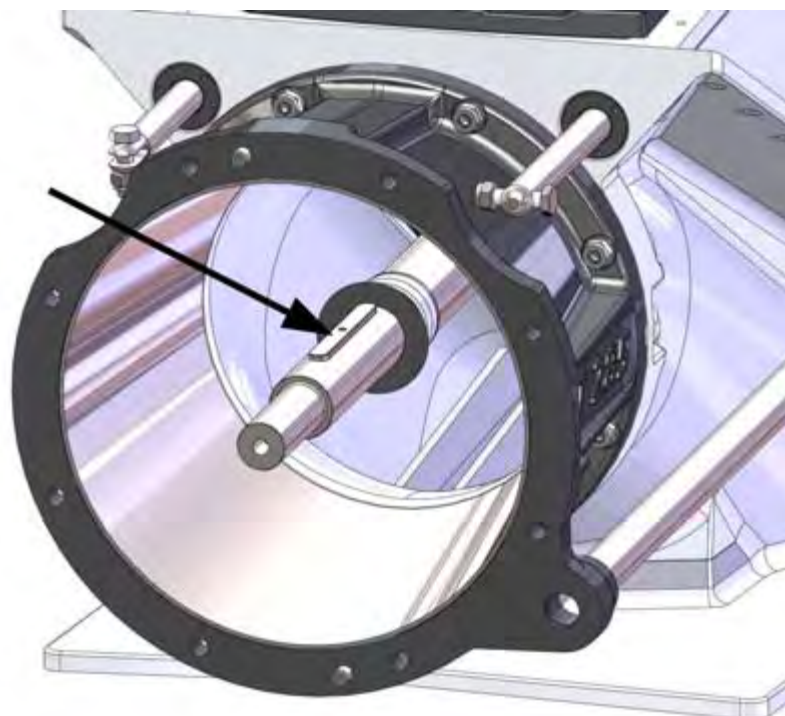

Figure 37. Keyway

If you adjusted the impeller during periodical maintenance and had to remove shim rings due to the impeller having worn down, do not throw away the shim rings. They are placed between the impeller and the shaft sleeve (figure 38). When installing a new impeller with a larger diameter, shim rings are moved from the back of the impeller to the front (figure 39).

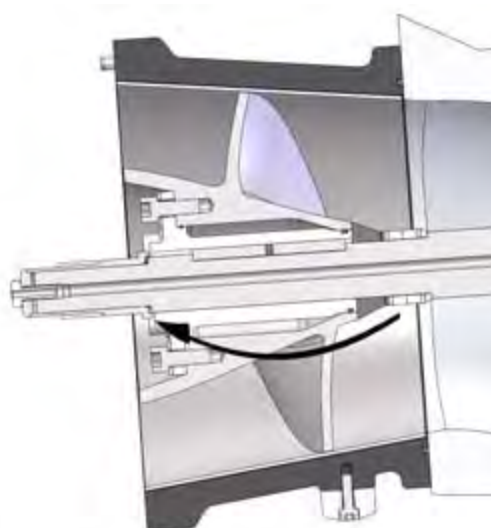

Figure 38. The impeller moves forward (wearing/gap needs to be reduced)

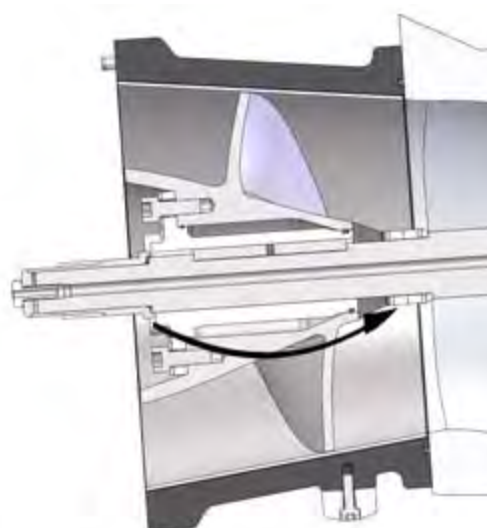

Figure 39. The impeller moves backward (new impeller/gap needs to be increased)

7. Lubricate the the inner surface of the sleeve to be placed at the end of the shaft with waterproof petroleum jelly (such as Shell Gadus S2 V220AC or similar).

8. Place the o-ring on to the shaft against the shoulder (figure 40, point A) and the shim rings against the rear surface of the impeller.
9. Push the sleeve on to the shaft.

Checking the position of the sleeve:

You can check whether there is an adequate number of shim rings behind the impeller by measuring distance *d* from the end of the shaft to the rear end of the sleeve (figure 37). The correct distance is 3.5 mm.

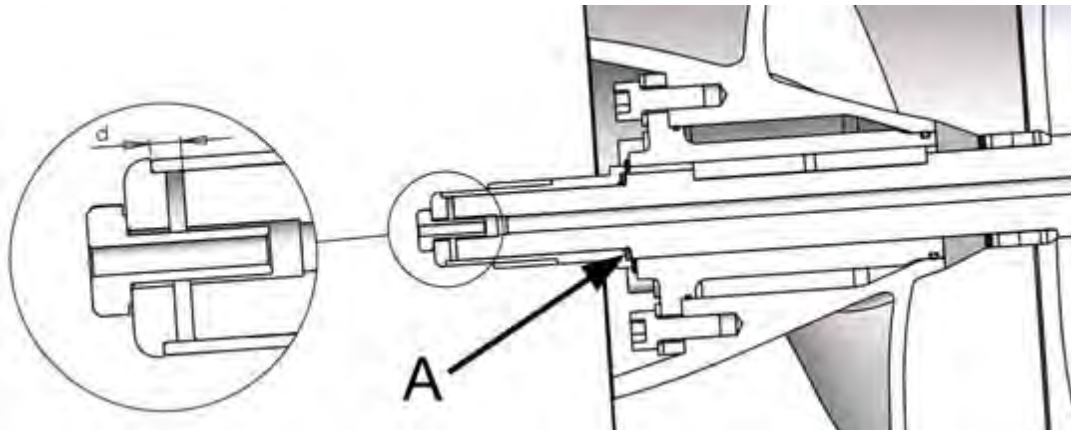

Figure 40. Checking the position of the sleeve

1. Once the sleeve is correctly positioned, place the locking plate to the end of the shaft and tighten the rear screw to a torque of 46 Nm.

Apply thread locking compound (such as Loctite 242) to the screw.

2. Make sure that the impeller cannot move forwards or backwards from its place.

4.9. Intermediate shaft

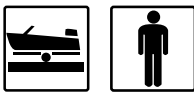

The intermediate shaft which is connected between the jet and the engine usually depends on the boat manufacturer. Contact the shaft's manufacturer for information on the maintenance of the intermediate shaft.

Regardless of the manufacturer, the alignment of the intermediate shaft must be kept accurate. The alignment must be checked at least once every driving season (year).



WARNING!

The intermediate shaft must absolutely be of high enough quality and properly balanced. An intermediate shaft that has been installed or balanced incorrectly can cause excessive damage to the propulsion unit.



WARRANTY!

If an intermediate shaft that has been installed or balanced incorrectly causes damage, this will not be covered by the warranty.

5. Problem situations

5.1. Cavitation



The most common malfunction in water jet propulsion units manifests as cavitation. Cavitation is a phenomenon in which the water pressure decreases locally to such an extent that water vaporises on the surface of the impeller blade, creating steam bubbles. The bubbles move on the surface of the blade and when they reach a higher pressure area they collapse.

Signs of cavitation are engine overdrive and stopping of thrust, and it can often be heard as a thundering sound.

Cavitation reduces performance considerably and damages the impeller. Any factor that hinders the flow of water in the jet increases the chance of cavitation. Usually the cause is the reduction of pressure in the whole intake duct caused by a blockage.

If cavitation is apparent or the boat runs slowly even though the engine runs on high revolutions, investigate the cause.

Checking the causes for cavitation:

1. Open the inspection hatch (figure 41).



Figure 41. Opened inspection hatch

2. Check the grass rake (figure 42).

Make sure that grass, reed, plastic, stone or some other extraneous object is not clogging the grass rake. Remove any possible blockages.

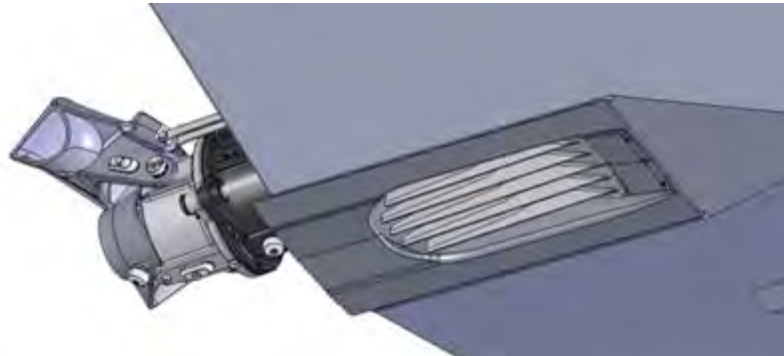

Figure 42. Checking the grass rake for blockages

3. Check the stator or nozzle unit (figure 43).

Make sure there are no extraneous objects (such as rope or reed entangled in the drive shaft, stones in the outlet port). Remove any possible blockages.

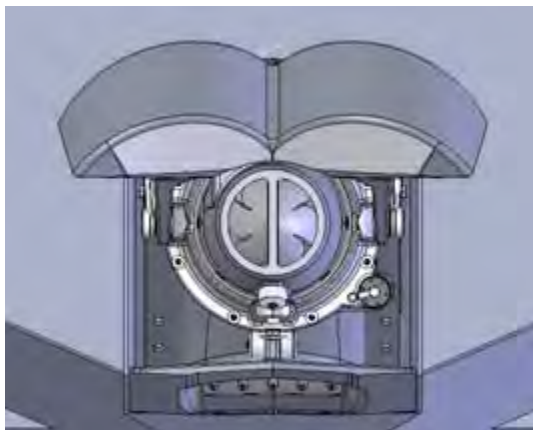

Figure 43. Checking the stator for blockages

4. Check the impeller.

Make sure there are no extraneous objects and that it is not damaged. The impeller should be smooth with no sharp cuts. Remove possible extraneous objects and fix the impeller if it is damaged (section 4.8. *Impeller*, page 25).

5. Close the inspection hatch.
6. Tighten the inspection hatch wing screw by hand.

5.2. Ventilation



Ventilation produces similar symptoms and sounds like cavitation (section 5.1. *Cavitation*, page 39), but is caused by different reasons.

Ventilation is created when air gets into the intake duct. The air causes the impeller to lose grip and the thrust weakens.

Ventilation can be caused by the following, for example:

- The inspection hatch cover is open or the seal is damaged.

Close the inspection hatch if it is open. Change the seal if it is damaged (section 4.5. *Seals*, page 19).

- The installation height of the jet is wrong and air is allowed to pass along the surface of the cavitation plate into the intake duct.

In this case the jet must be reinstalled. Consult the boat's retailer.

- During installation, places accordant with the instructions have not been sealed.

In this case, the sealing must be done again. Consult the boat's retailer.

5.3. Clogged jet

Driving among water plants or in ice sludge can clog the jet. If this happens, the blockage can stop the boat from moving.

With these simple instructions it is possible practically without exception to clean very difficult blockages from the jet. Unlike with other propulsion units, in boats equipped with a jet the engine stops very rarely as a result of a water plant blockage. However, ice sludge can clog the jet so badly that the blockage cannot be removed without lifting the boat out of the water.

Boats equipped with a gearbox



In boats equipped with a gearbox, cleaning the jet is easy because in reverse gear a back flow is created in the intake duct.

Cleaning the jet:

1. Put the gear in reverse.
2. Use some acceleration to detach the blockage.



WARNING!

The jet is designed to run in reverse only for one minute at a time and at under 2,000 rpm. This is usually enough to clear the blockage.

Too heavy a load in reverse gear can lead to jamming of the impeller or breaking down of hydraulics.

Boats without a gearbox



If the boat has no gearbox, cleaning the jet may require several phases.

Cleaning the jet:

1. Stop the engine.

This usually helps drop any extraneous objects from the grass rake.

2. Let the engine run on high revolutions for a few times.

This often sucks the extraneous objects through the jet and cleans it.

3. If the boat is moving ahead, raise the speed of the boat as high as possible and then shut down the engine.

The speed of the boat often sweeps the grass rake clean.

4. Drive the boat in reverse as fast as possible. As the boat moves astern, shut down the engine and move the deflector control lever to the forward position.

This causes water to flow backwards through the jet and usually opens all kinds of blockages.

Difficult blockages

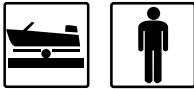

If the aforementioned measures do not remove the blockage, you can locate the blockage through the jet's inspection hatch and remove it manually.

Removing a blockage through the inspection hatch:

1. Open the inspection hatch (figure 44).



Figure 44. Inspection hatch

2. Locate the blockage and remove it manually.
3. Close the inspection hatch.
4. Tighten the inspection hatch screws (4 pcs) by hand.



WARNING!

Do not open the inspection hatch when the engine is running. There is a rotating shaft behind the hatch.



TIP!

Keep a long tube in the boat for removing stones or other objects wedged between the grass rake.

Appendix 1. Declaration of incorporation for partially completed machinery

(Machinery Directive 2006/42/EC, Annex II, 1.B.)

Manufacturer:	Alamarin-Jet Oy Tuomisentie 16 FI-62300 HÄRMÄ
Compiler of the technical file:	Hannu Rantala, Technical Manager Alamarin-Jet Oy Tuomisentie 16 FI-62300 HÄRMÄ
Description of the partially completed machinery:	Water jet propulsion device
Operation of the partially completed machinery:	The device is intended to be used as the propulsion device of a motor boat. A propulsion device transforms the torque of the motor into propulsive force.
Model and type of the partially completed machinery:	AJ 285
Serial number of the partially completed machinery:	_____

Alamarin-Jet Oy guarantees that the abovementioned partially completed machinery meets the requirements of the Machinery Directive (2006/42/EC) and the validating national regulations.

In addition, the company guarantees that

- the specific technical documents related to the partially completed machinery have been created according to section B of Annex VII in the Machinery Directive (2006/42/EC), and
- the following harmonised standards are applied: SFS-EN-ISO 12100-1 and SFS-EN-ISO 14121-1.

Alamarin-Jet Oy also undertakes to deliver the documents related to the partially completed machinery to the relevant national authority in electronic format if so requested.

The partially completed machinery must not be introduced to use before the final equipment to which it is intended to be attached has been declared to conform to the requirements of this Directive.

Place: Kauhava

Date and Signature

Appendix 2. Grease recommendations

The grease used for lubricating the propulsion unit bearing must meet the following requirements:

- lithium soap and a thickener with EP additives
- mineral oil as a base oil
- NLGI class 2
- operating temperature range -25 to 130°C (-13-266 °F)
- continuous operating temperature min. 75 °C (167 °F)

Recommended grease brands:

- Würth Multi-Purpose Grease III
- FAG Multi2
- FAG Load 220
- Mobil XHP 222
- Neste Allrex EP2
- Shell Retinax Grease EP2

A grease that has equivalent properties to those mentioned above can also be used for lubrication.

Appendix 3. Oil recommendations

The operating hydraulic system of the reversing deflector and the lubrication of the front bearing are designed to use oil that is specifically intended for automatic transmission systems. The oil must meet the following requirements:

Kinematic viscosity 40°C	33-36 mm ² /s
Kinematic viscosity 100°C	7.1-7.7 mm ² /s
Viscosity index	min. 170
Density 15°C	0.835-0.890 g/cm ³
Pour point	max. -42 °C
Flashpoint	min. 180 °C

Recommended oil brands:

- Mobil ATF 320
- FormulaShell ATF DEXRON III
- Neste ATF-X
- BP Autran DX III

Appendix 4. Tightening torques

Use the tightening torques from the table 4 when tightening the propulsion unit screws. The strength grade of an acid-proof A4-80 screw is equivalent to a class 8.8 screw.

Table 4. Tightening torques of the screws

	Strength grade		
	8.8	10.9	12.9
Thread	Tightening torque (Nm) (*)		
M5	5.5 (4)	8.1 (6)	9.5 (7)
M6	9.6 (7)	14 (10)	16 (12)
M8	23 (17)	34 (25)	40 (30)
M10	46 (34)	67 (49)	79 (58)
M12	79 (58)	115 (85)	135 (100)
M16	145 (107)	215 (159)	250 (184)

(*) The tightening torque in pound-feet (approximate value) is marked in the table in parentheses after the corresponding value in Nm.

A suitable thread locking compound that is good for all purposes is one of medium strength, for example. Loctite 242 or similar.

Appendix 5. Test report

It is recommended that a speed test report is filled out when the boat is commissioned. The performance of the boat can later be compared to this report for the purpose of finding potential faults. The report template can be found on the following page.

Customer:		Date:	
Project/vessel:			
ID:			

Test location:			
Air temperature:		°C	Seastate:
Water temperature:		°C	Wind: <input type="text"/> m/s from <input type="text"/>

Jet type:		Number of units:	
Impeller type:		Nozzle size:	

Engine type:			
Rated power:		kW	@ crankshaft [rpm]

Transmission type:		Reduction ratio:	
--------------------	--	------------------	--

Load condition (total weight including all)

Test 1:		kg	LCG=	<input type="text"/>	m
Test 2:		kg	LCG=	<input type="text"/>	m

Test 1

RPM	Speed 1	Speed 2	Average
1000			
1200			
1400			
1600			
1800			
2000			
2200			
2400			
2600			
2800			
3000			
3200			
3400			
3600			
3800			
4000			
4200			
4400			
4600			

Test 2

RPM	Speed 1	Speed 2	Average
1000			
1200			
1400			
1600			
1800			
2000			
2200			
2400			
2600			
2800			
3000			
3200			
3400			
3600			
3800			
4000			
4200			
4400			
4600			

Instructions: Weight is to be calculated including all weight on board
 speed 1 and speed 2 are measured to opposite wind directions

Alamarin-jet will treat all information supplied by you as strictly confidential.

Warranty & Ownership Registration Card

Alamarin-Jet Owner Identification Card

Complete the Warranty registration card and send the factory copy to:

Alamarin-Jet
Tuomisentie 16
FI-62300 Härmä
Fax: +358 10 7745 269
sales@alamarinjet.com

Owner's Name	email	
Address		
City	State	Zip
Date Of Commissioning		
Alamarin Jet Model	Serial Number(s)	
Project / Vessel		
Contact Name	Signature	



Dealer Record Card

Alamarin-Jet Owner Identification Card

Alamarin-Jet
Tuomisentie 16
FI-62300 Härmä
Fax: +358 10 7745 269
sales@alamarinjet.com

Owner's Name	email	
Adress		
City	State	Zip
Date Of Commissioning		
Alamarin Jet Model	Serial Number(s)	
Project / Vessel		
Contact Name	Signature	