

N13.800 CR3

SPECIFICATIONS

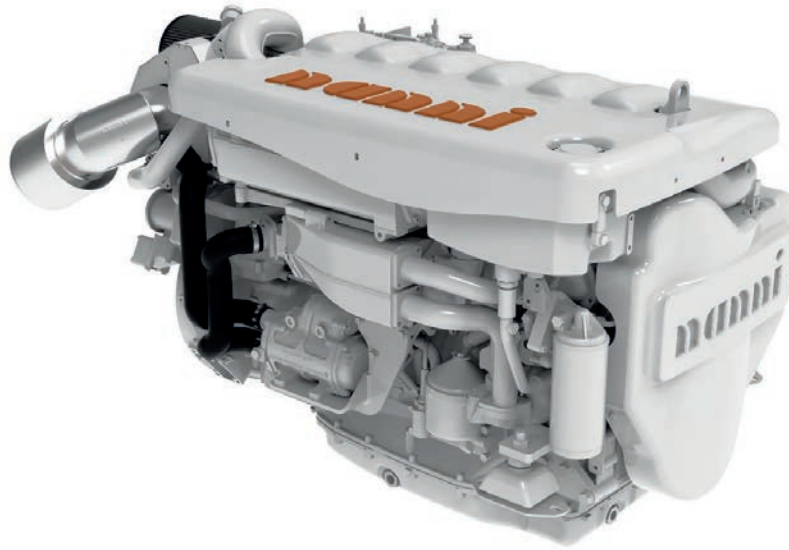

Power at crankshaft	588 kW [800 hp]	Engine base	Scania
Displacement	12.7 l [775 in ³]	Fuel system	Extra High Pressure Injection (XPI)
Configuration	6 cylinders in line	Air intake	Turbocharged with after cooler
Operation type	4 stroke Diesel	Cooling	Closed cooling with heat exchanger and charge air cooler
Bore & Stroke	130 x 160 mm [5.1 x 6.3 in]	Max mounting angle	12° Front down 12° Front up
Compression ratio	17.3 : 1	Alternator	24 Volt 100 Amp
Rated speed	2300 rpm	Rating	M6.S / M5.L
Idling speed	600 rpm	Emission compliance	US tier 3 IMO Tier II EU Stage IIIA RCD2
Peak torque	3120 Nm	Dry weight	1285 kg [2833 lbs]
Peak torque speed	1600 rpm		

N13.800 CR3

588 kW [800 hp] at 2300 rpm

TECHNICAL DESCRIPTION

ENGINE BLOCK

- Extra high pressure fuel injection system, XPI
- Turbocharger
- Protection covers

FUEL SYSTEM

- Scania Engine Management System, EMS
- Fuel pre-filter with water separator
- Fuel filter

LUBRICATION SYSTEM

- Oil filter, full flow
- Centrifugal oil cleaner
- Oil cooler, integrated in block
- Oil filter
- Oil draining with plug
- Shallow oil sump
- Oil dipstick

COOLING SYSTEM

- Sea water pump

ELECTRICAL SYSTEM & INSTRUMENTATION

- Starter, 2-pole 7.0 kW
- Alternator, 2-pole 24V / 100A

OTHER FEATURES

- Flywheel SAE 14"
- Silumin flywheel housing, SAE 1 flange
- Front-mounted engine brackets
- Closed crankcase ventilation
- Air cleaner
- Flexible engine mounting
- Damper pulley

OPTIONAL SYSTEMS & ACCESSORIES

- Hydraulic pump
- Side-mounted PTO (SAE A)
- Axial front-mounted PTO
- Exhaust connections
- Engine coolant heater
- Stiff rubber suspension
- Oil draining with pump
- Oil level sensor
- Bilge pump

RATINGS

M6.S

- Up to 500 annual operating hours
- Load factor up to 50%
- Full power for no more than 1 hour out of each 12 hours of operation. The remaining operation time must be at or below cruising speed

M5.L patrol craft long

- Up to 2000 annual operating hours
- Load factor up to 77%
- Full power for no more than 1 hour out of each 6 hours of operation. The remaining operation time must be at or below cruising speed

TRANSMISSIONS

- Contact your Nanni representative for more details and availability about transmissions types and models range.

PERFORMANCE CURVES

POWER AT CRANKSHAFT

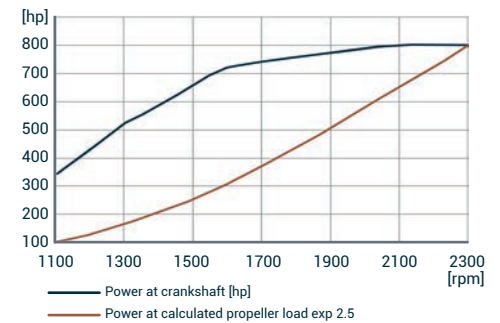

TORQUE AT CRANKSHAFT

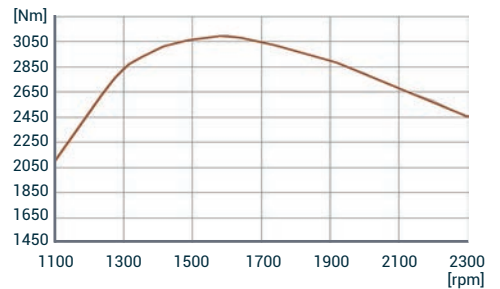

FUEL CONSUMPTION

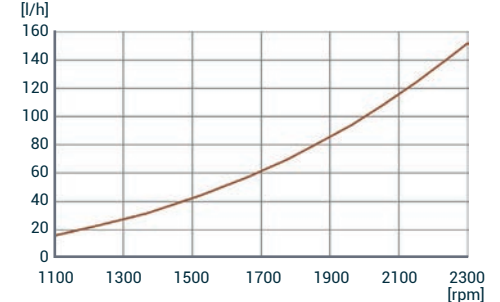

DIMENSIONS

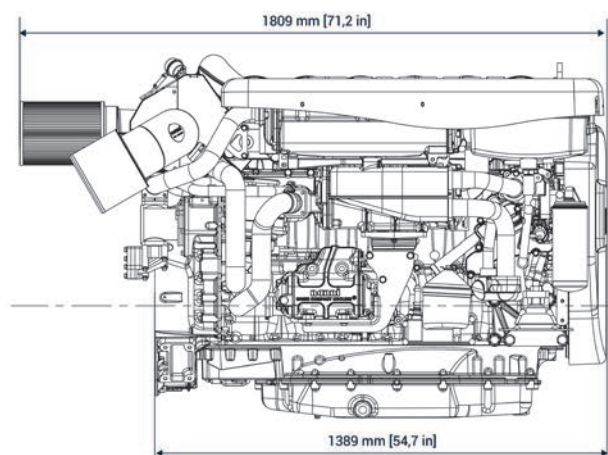
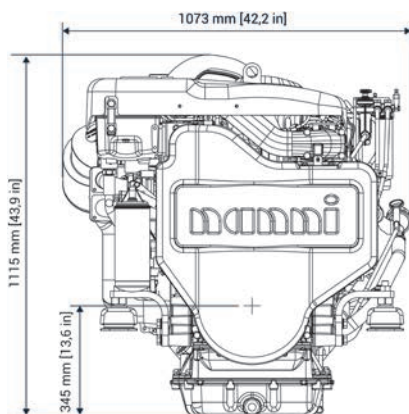

NANNI INDUSTRIES S.A.S.

11, Avenue Mariotte - Zone Industrielle
33260 La Teste - France
Tel: +33 (0)5 56 22 30 60
Fax: +33 (0)5 56 22 30 79

Technical data according to ISO 8665. This document is not contractual. Nanni reserves the right to modify any of the characteristics stated in this document without notice, in a constant effort to improve the quality of its products. Images and illustrations may show non standard equipments. All combination of equipment & accessory are not available.

DGBXXC01048