

Installation Manual

Go with the flow.

alamarinjet



AJ 288

Table of contents

1. Introduction	1
1.1. Safety precautions	1
1.2. Symbols	1
2. General description of installation	3
3. Attaching the installation insert	5
3.1. Repowering installation	5
3.1.1. Reinforced plastic installation insert	6
3.1.2. Aluminium installation insert	12
3.1.3. Embedding the installation insert to the hull of the boat....	13
3.2. Installation out of the mould	14
3.2.1. Removable installation insert	14
3.2.2. Fixed installation insert	16
4. Attaching the propulsion unit	19
4.1. Preparations	19
4.2. Attaching the frame	20
4.3. Installing the lubrication system for the bearing	21
4.3.1. Front bearing	21
4.3.2. Rear bearing	23
4.4. Attaching the hydraulic cylinder	26
4.5. Attaching the hydraulic pump	29
4.6. Installing the cooling line for hydraulic cylinder oil	31
4.7. Attaching the intake screen	33
4.8. Installing the raw water cooling line	33
5. Installing the control system	37
5.1. Connecting the reversing deflector to the control system	37
5.1.1. Connecting the control cables	40
5.1.2. Cylinder adjustment	41
5.2. Connecting the steering nozzle to the control system	43
6. Engine installation	45
7. Antifouling	47
Appendix 1. Grease recommendations	49
Appendix 2. Oil recommendations	50
Appendix 3. Tightening torques	51
Appendix 4. Installation insert	52
Appendix 5. Change in the v angle	53
Appendix 6. Connecting rod for twin installation	54
Appendix 7. Control system hydraulic line	55
Appendix 8. Control systems	58
Appendix 9. Lever movement ranges	60



WARRANTY TERMS

Warranty for the Alamarin-Jet products is 12 months from the first sea trial. However no longer than 18 months from the date of delivery from our factory.

Alamarin-Jet Warranty covers defects in Alamarin-Jet workmanship and materials for the Warranty period. Alamarin-Jet warranty terms will not cover normal part wear nor following cases with external source of issue: incorrect installation, damage caused by outside affect, vessel overloading, misuse, abnormal wear and tear, accident, improper application, improper transportation or storage, natural calamity, unsuitable water conditions, lack of maintenance or neglecting correct procedures described in Alamarin-Jet manuals.

Any Alamarin-Jet product that is serviced, repaired or altered in any way by anyone other than party certified by Alamarin-Jet will not be covered by the warranty terms. Modifying or repairing Alamarin-Jet products with any other than original Alamarin-Jet parts will lead immediate invalidation of Alamarin-Jet product warranty.

Alamarin-Jet Warranty terms excludes indirect costs: Crane rent, docking, warping, towing, assistance of yard crew and services, loss of profit, travel, hotel charges, daily allowances and waiting time, expenses of unauthorized repair work of Alamarin-Jet products, expenses caused by failure of the jet to other components inside or outside the vessel, damages to any third parties, injuries, or any other inconveniences.

In order for warranty decision, Alamarin-Jet must receive defected parts with comprehensive failure description attached and transportation charges covered by the purchaser to Alamarin-Jet for inspection. Based on given details and inspected product, Alamarin-Jet reserves rights to define whether the case is under warranty. After inspection Alamarin-Jet will provide documented description for the customer regarding the case.

In case replacement parts are needed before Alamarin-Jet has analyzed the returned parts, purchaser buys new replacement parts. After confirming potential warranty decision, Alamarin-Jet will provide credit note covering the parts under warranty. All products and parts removed or replaced under the Warranty shall become property of Alamarin-Jet.

Alamarin-Jet reserves exclusive right for Alamarin-Jet warranty terms and no other person or distributor is authorized to modify this Warranty or give any other Warranty on behalf of Alamarin-Jet.

Alamarin-Jet Oy reserves its right to change, amend, add or delete any of the Terms and Conditions without prior notice. Any disputes are to be settled according to Finnish law by arbitration in Helsinki, Finland according to the rules of the International Chamber of Commerce and in accordance with Finnish legislation of Arbitration.

2017/5/10

GO WITH THE FLOW

1. Introduction

This is the installation manual for Alamarin-Jet's AJ 288 water jet propulsion unit. This manual is intended for mechanics who install the Alamarin-Jet water jet propulsion unit to a suitable boat.

© Alamarin-Jet Oy

Tuomisentie 16
FI-62300 Härmä, Finland
Telephone: +358 10 7745 260
Fax: +358 10 7745 269
Internet: www.alamarinjet.com

All rights reserved.

The information in this manual may not be copied, published or reproduced in any way whatsoever, or exploited for commercial purposes, without express written permission from Alamarin-Jet Oy.

The information in this manual is subject to change without notice. Alamarin-Jet Oy reserves the right to modify the contents without notice.

1.1. Safety precautions

Read these instructions carefully before carrying out any procedures. Always follow these instructions and the safety precautions shown below.





- Only a person with adequate training is allowed to carry out the procedures described in this manual.
- The person carrying out the procedures must always wear the appropriate protective equipment.
- The work premises must be sufficiently large, safe and well-lit.
- The tools that are to be used must be clean and appropriate for the intended purpose.

1.2. Symbols

Please refer to table 1 for a description of the symbols used in this manual.

Table 1. The symbols used in the manual

Icon	Description
	DANGER Negligence in the performance of a procedure can cause a threat to your life.
	WARNING Negligence in the performance of the procedures can lead to personal injury, breakdown of equipment, or serious malfunction of the equipment.
	CAUTION The procedure involves minor danger or a possibility of minor damage to equipment.

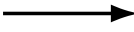
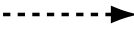
Icon	Description
	WARRANTY The warranty is voided if the procedure is carried out incorrectly.
	NOTE Important notice or fact.
	TIP Additional information that facilitates the performance of work or a procedure.
	CARRIED OUT BY ONE PERSON One person can carry out the procedure.
	CARRIED OUT BY TWO PERSONS Two persons must carry out the procedure.
	INDICATOR ARROW
	ARROW DESCRIBING MOTION

Please note that this instruction uses the terms "jet" and "jet propulsion unit". They mainly refer to the same thing.

2. General description of installation

Alamarin-Jet water jet propulsion units can be installed on a reinforced plastic, aluminium, steel, polyethylene, or wooden boat.

Perform the installation in the following order:

1. Attach the installation insert to the boat's hull (section 3. *Attaching the installation insert*, page 5).
2. Attach the propulsion unit to the installation insert (section 4. *Attaching the propulsion unit*, page 19).
3. Install the control system (section 5. *Installing the control system*, page 37).
4. Install the engine (section 6. *Engine installation*, page 45).
5. Paint the propulsion unit with antifouling paint (section 7. *Antifouling*, page 47).

This is only necessary if the boat is used in waterways where organisms are likely to attach themselves to the propulsion unit.

3. Attaching the installation insert

The Alamarin-Jet water jet propulsion unit is installed on the boat using an installation insert. The installation insert consists of an intake duct and an installation surface for the propulsion unit (figure 1).

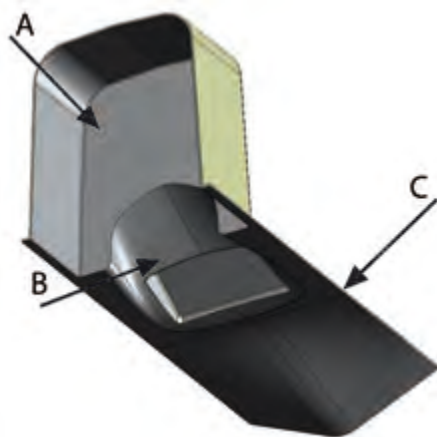

Figure 1. Installation insert

- A Installation surface
- B Intake duct
- C Edge parallel to the keel

The installation insert determines the propulsion angle of the propulsion unit. The angle between the installation surface and the edge parallel to the keel is 4° over the right angle. The main shaft of the propulsion unit then slants 4° downwards by reference to the keel. If the design of the boat requires a different thrust angle, the matter must be handled and arranged with Alamarin-Jet Oy.

An installation insert will be delivered with the propulsion unit on request. The installation insert delivered with the propulsion unit is made of aluminium or fibreglass, depending on the material of the boat.

The installation insert can be installed directly out of the mould or by using modification installation (repowering).

3.1. Repowering installation

The repowering installation method is used in the propulsion system's modification installation. In addition, it is an appropriate installation method for prototype or one-off boats. In aluminium boats, the propulsion unit is always installed using the repowering principle.

For attaching the installation insert, a hole of an appropriate size is cut in the transom and the bottom of the boat, in which the installation insert is either laminated or welded.

3.1.1. Reinforced plastic installation insert



If the installation is done on a boat that has previously had some other type of rear propulsion unit, make sure that the engine's installation supports do not impede laminating. There must be at least 150 mm of free hull surface on all sides of the installation insert, on which the installation insert can be laminated (figure 2) The same 150 mm requirement applies to all boats, including new ones.



Figure 2. Repowering installation

Hull and transom laminate must be dry and clean before work can be commenced.

Cutting and attaching the installation insert:

1. Cut the installation insert to the right size at the front.

The v angle of the installation insert is dynamic, and the installation insert is cut to suit the v angle of the boat (figure 3).

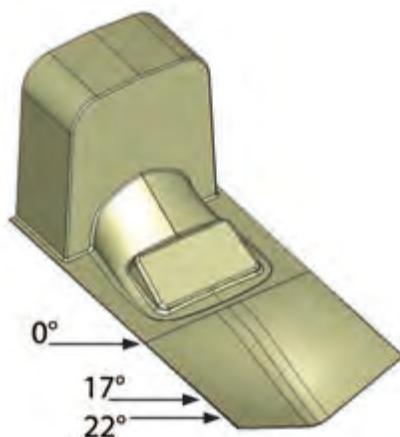

Figure 3. Cutting the installation insert

0° = flat-bottom installation



NOTE!

The angles and dimensions in the picture are illustrative and indicative. They do not correspond to reality.

The appendix 4. *Installation insert*, page 52 depicts how the cutting point depends on the v angle. To achieve a flat-bottomed installation insert, shorten the installation insert to the length of 361 mm, measured from the installation surface.

The appendix 5. *Change in the v angle*, page 53 shows the distance of the cutting point from the jet's installation surface.

The right cutting point depends on the roundness of the keel and therefore it is important to fit the forms together precisely (figure 4).

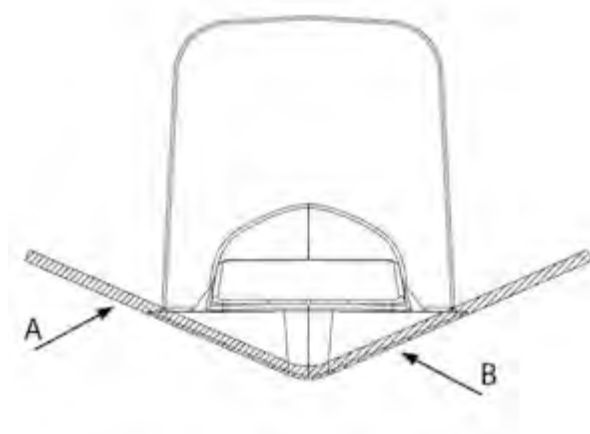

Figure 4. Effect of the keel's roundness

A Boat bottom

B The installation insert and the boat bottom on the same level

2. Cut a hole of appropriate size for the installation insert in the transom and the bottom of the boat.



TIP!

It is easier to find the right cutting point if you make a v gauge out of two straight laths and then compare the shape of the boat's bottom and the shape of the installation insert (figure 5).

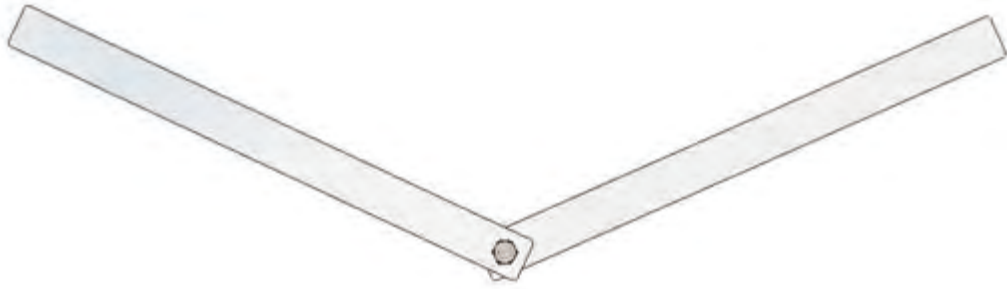

Figure 5. V gauge

The hole should be cut so that the installation insert is as far back as possible (figures 6 and 7).

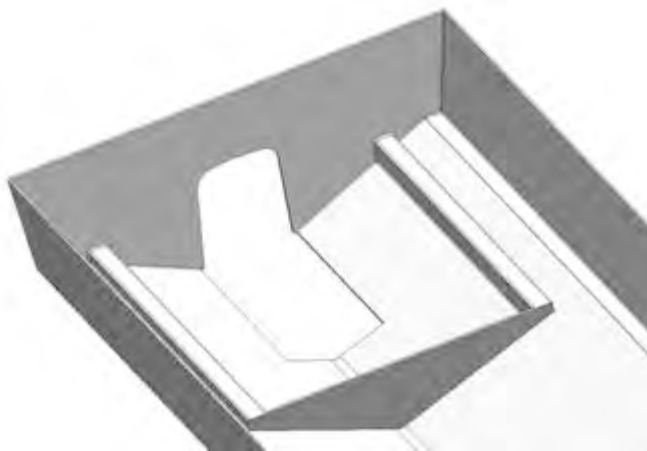

Figure 6. Installation insert hole

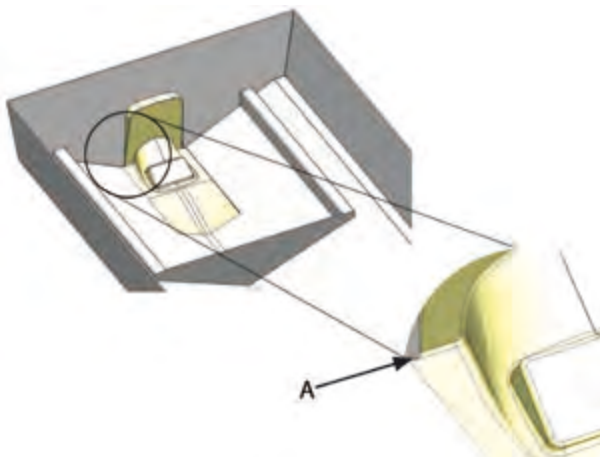

Figure 7. Installation insert gap

A The bottom part of the installation insert must be level with the inner surface of the transom.

The installation insert must be on the same level with the bottom of the boat (figure 8). The gap between the installation insert and the hull should be fitted so that it is as small as possible. A gap of 2-5 mm is acceptable.



Figure 8. Bottom and installation insert level

3. Chamfer the edges of the hole all around.

The chamfered part must be 150 mm wide and the hole edge thickness must be 3 mm. However, here the chamfered part does not have to be as long as that on the hull.

If the boat's hull is made of sandwich laminate, first remove 100 mm of core material round the hole and then chamfer the core material as well as about 100 mm of the inner envelope. Slightly chamfer the exterior surface as well.

4. Fit the installation insert in place and support it from the outside (figure 9).



NOTE!

The lower surface of the installation insert must be level with the bottom of the boat.

The edge of the installation insert must be parallel with the boat's keel (= the edge of the hole).

If this is not the case, the propulsion unit thrusts the boat in the wrong angle and performance is lowered.

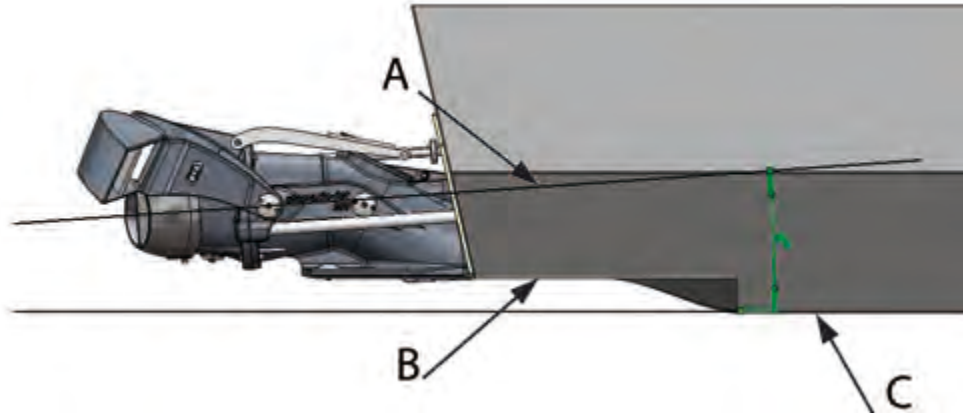

Figure 9. Installation insert alignment

- A Main shaft centre line
 - B Edge of the cut installation insert (parallel with the keel)
 - C Keel line
5. Close the seam with tape from the outside.
 6. Run gelcoat paint onto the seam from above until it is filled.
 7. Laminate 100 mm-wide mat strips on the seam.
 8. Remove the strut at this point, if there is one in place (figure 10).

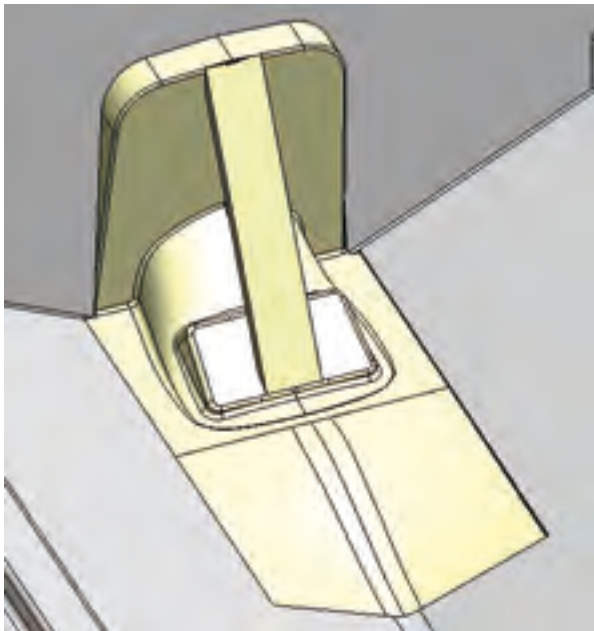

Figure 10. Strut

9. Continue laminating over the whole installation insert and the chamfers until the final thickness of 20 mm is achieved (figure 11).

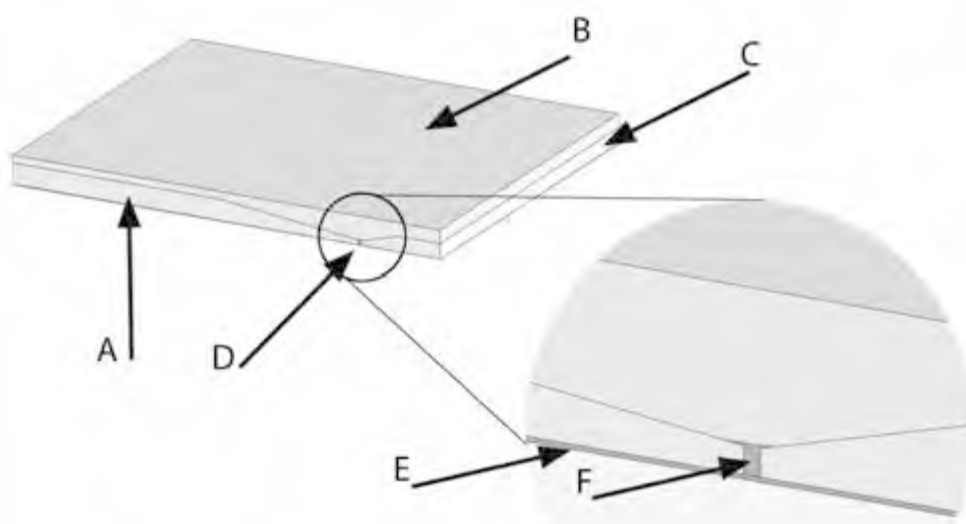

Figure 11. Laminating

- A Boat hull laminate
- B Attachment laminate
- C Installation insert laminate
- D Seam
- E Original gelcoat
- F Seam-filling gelcoat

10. Fit engine supports and possible bracings.
11. Cut off the excess collar on the installation insert outside the transom (figure 12).

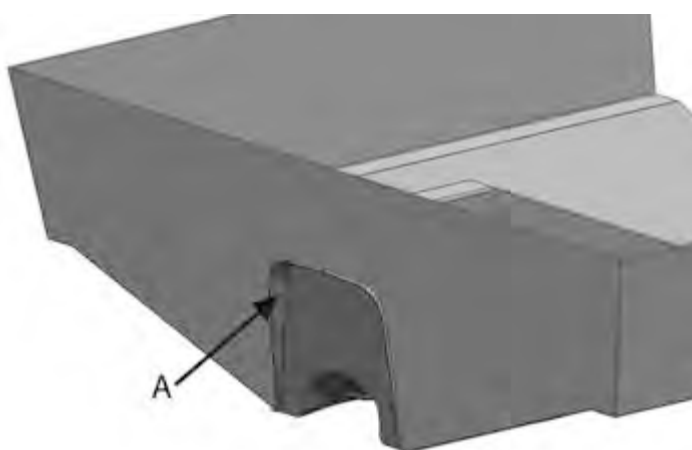

Figure 12. Excess collar

12. Smooth the seams and paint the visible reinforced plastic surfaces with topcoat paint.

This is important because an uncovered laminate absorbs water.

3.1.2. Aluminium installation insert



The aluminium installation insert is suitable for flat-bottom installation as such. Attaching to a v bottom is done with a triangular plate (figure 13). The length of the triangular plate must at least 600 mm measured in the direction of the keel.

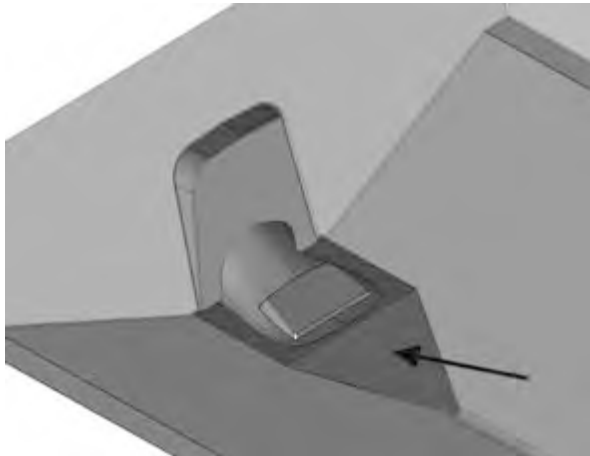

Figure 13. Triangular plate

Attaching the installation insert:

1. Cut the installation insert to suit flat-bottom installation (section 3.1.1. *Reinforced plastic installation insert*, page 6, step 1).
2. Cut a suitable hole in the bottom and the transom of the boat (section 3.1.1. *Reinforced plastic installation insert*, page 6, step 2).

The hole should be cut so that the installation insert is as far back as possible. The gap between the installation insert and the hull should be fitted so that it is as small as possible.

3. Chamfer the plate edges as required by general welding standards.
4. Attach the installation insert in place (section 3.1.1. *Reinforced plastic installation insert*, page 6, step 4).
5. Weld the installation insert in place both on the inside and the outside, and make the seam watertight.
6. Abrade the welded seams so that they are smooth at the bottom area.

Any uneven spots at the bottom must be trimmed by caulking, for example.

7. Paint the installation insert with two-component paint suitable for painting aluminium.

Follow the paint manufacturer's instructions.



CAUTION!

Painting is important, because the intake duct is cast aluminium.

The structure of cast aluminium is porous and it can absorb water. This can accelerate the corrosion process.

The material of the cast section of the aluminium installation insert: AlSi7Mg

The material of the plate section: AlMg3

Welding filler metal: AlMg5

3.1.3. Embedding the installation insert to the hull of the boat



If for some reason you want to shorten the length of the jet outside the stern, you can embed the installation insert deeper into the hull. You can make use of the collar on the installation insert to determine the space you will need for this. However, the top of the collar must be lengthened to accommodate the inspection hatch (figure 14, point A). The length of the mounting template collar is 200 mm. Do not embed the jet further into the hull than this. Otherwise the jet flow from the reversing deflector will hit the transom. In this kind of installation, the size and positioning of trim tabs must be determined individually.

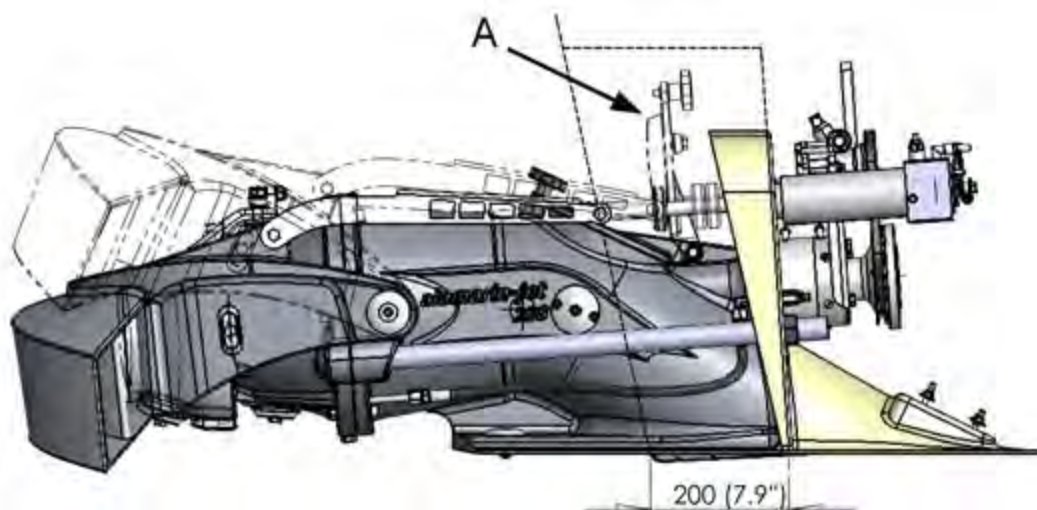

Figure 14. Embedding the installation insert

3.2. Installation out of the mould



If you want to produce one type of boat with several varying propulsion unit options, it is possible to make a mould of the installation insert and fit it to the standard hull mould (figure 15). This speeds up installation of the propulsion unit without adding to mould expenses.

The mould for the installation insert is made from an installation insert provided by Alamarin-Jet Oy. In twin installations, two moulds must be made, one for each side of the hull.



CAUTION!

Prepare the installation insert to fit exactly in the boat's mould. This must be done carefully, as inaccuracies (bulges) are copied to the final boat and result in deterioration of boat performance.

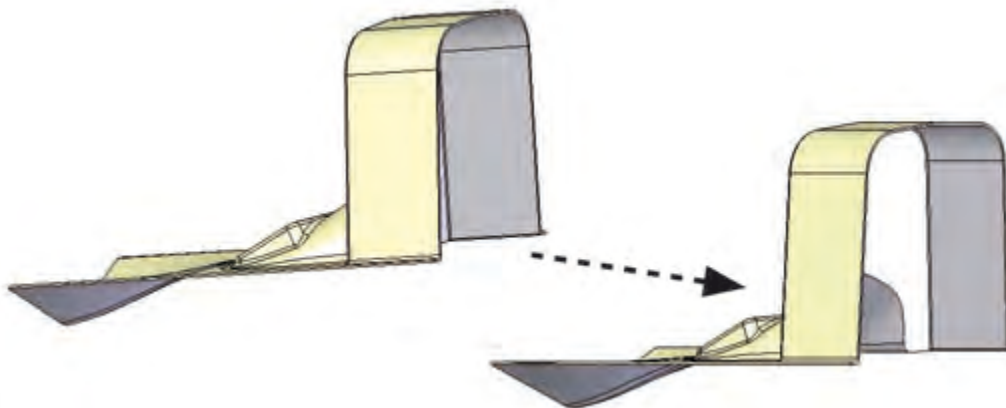

Figure 15. Making a negative of the installation insert

3.2.1. Removable installation insert

If you use a removable installation insert, you can use the boat's hull mould in both jet installation and rear propulsion unit installation. There are three stages in preparing and installing a removable installation insert:

1. Make a negative (mould) of the installation insert.
2. Adapt the negative to fit the mould exactly.
3. Install the installation insert on the boat.

All the stages, except for the first stage of processing the negative, apply both to single and twin installations.

Processing the negative:

1. Cut the excess fibreglass off the mould of the installation insert.

This only applies to twin installation.

2. Cut the collar of the installation insert in accordance with the transom of the mould.

The collar must be cut carefully and correctly. If the collar is not cut correctly, the consequence is that the intake duct position is wrong. The edge of the intake duct must be parallel with the keel.

In twin installations, this means cutting according to figure 16 when the transom is not vertical.

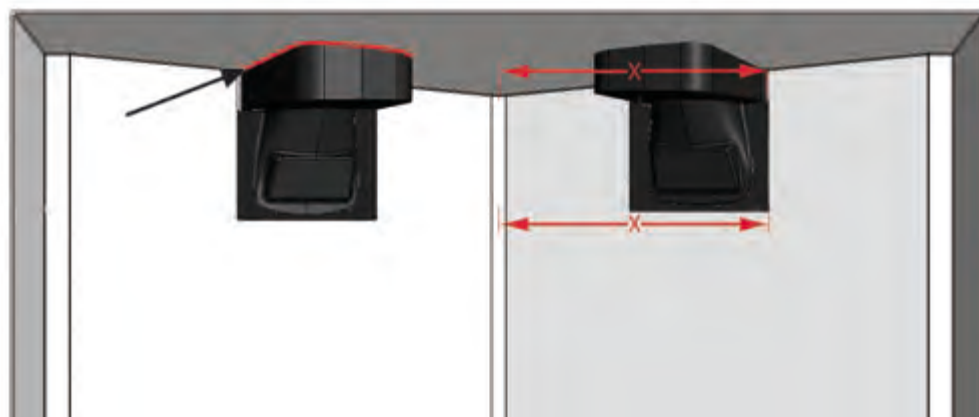

Figure 16. Cutting the collar (twin installation)

3. Sharpen the front edge and the sides of the intake duct negative so that no thick edge is left between the boat mould and the negative (figure 17).

If this is not done, the thick edge is copied to the final boat and the boat's performance may suffer.



Figure 17. Sharpened negative

4. Reinforce the collar of the installation insert negative with a wooden frame, a plywood plate or for example with urethane foam (figure 18).

This way the collar will not bend inwards during laminating.



Figure 18. Reinforced collar

Installing the installation insert on the boat :

1. Fit the installation insert negative in the boat mould so that the intake duct is parallel with the keel (figure 16).



TIP!

It is advisable to mark the location of the installation insert on the boat mould after the first installation. This makes fitting the installation insert faster and easier the next time.

2. Attach the installation insert negative on the boat's mould with tape or other temporary method.

Make sure that there are no big notches in the seams of the negative and the boat's mould. A notch caused by tape is not detrimental.

For the part of the jet's installation insert, the boat's mould is now ready for laminating. When laminating the boat, the paint that is spread first (gelcoat) solidifies the installation insert in place.



CAUTION!

Twin installation!

After the boat has been laminated and is ready to be removed from the mould, the installation insert negatives detach with the boat. The installation inserts are removed from the boat for the next installation.

3.2.2. Fixed installation insert

The installation insert can also be fixed to the mould. In this case, the boat's hull mould can only be used in jet installation. In twin installation, the boat's mould must be in two pieces in order to make separating the installation inserts possible. A two-piece mould is not necessarily needed for single installation.

Twin installation

1. Make two negatives of the installation insert.
2. Fit and install the installation inserts on the boat's mould (section 3.2.1. *Removable installation insert*, page 14).
3. Laminate the rear end of the boat in the mould and remove it.
4. Remove the installation inserts.
5. Make a separate mould of the rear end.

Single installation

1. Make a negative of the installation insert.
2. Fit and install the installation insert on the boat mould (section 3.2.1. *Removable installation insert*, page 14).
3. Laminate the hull of the boat in the mould and remove it.
4. Make a new mould of the hull.

4. Attaching the propulsion unit

The propulsion unit is attached to the boat one part at a time. Attachment is carried out in the following order:

1. Propulsion unit frame
2. Lubrication system for the bearings
3. Hydraulic cylinder
4. Hydraulic pump
5. Cooling line for hydraulic cylinder oil
6. Intake screen
7. Raw water cooling line

4.1. Preparations



Holes must be made on the installation surface of the installation insert for attaching the propulsion unit and for the required bushings. An aluminium installation insert is already equipped with the required holes.

Sawing/drilling the holes is carried out with the drilling templates that come with delivery.

Drilling the holes:

1. Set the template against the installation surface so that the texts are visible, and centre the template in relation to the ready-drilled centre hole.
2. Mark the holes and drill them.

The gauge has only a centre hole for large holes, and they are drilled to the right diameter with a hole saw. The name of the bushing and the final diameter are marked on the template for clarity (figure 19).



TIP!

It is advisable to first make one hole and use it to attach the drilling template to the transom. This way it stays in place when drilling the other holes.

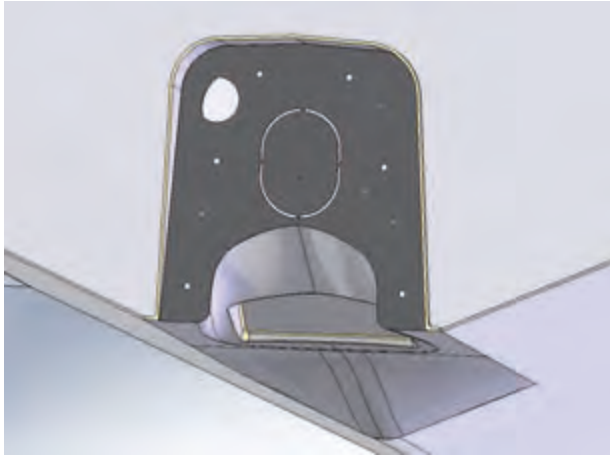

Figure 19. Drilling template

Before installation, make sure that

1. The installation surface is straight and clean.
2. The holes are drilled/sawn correctly.
3. Transom laminate does not get in the way of the propulsion unit and its auxiliaries, which means that the laminate is not too thick.
4. The following items have been removed from the propulsion unit:
 - Hydraulic cylinder
 - Steering shaft
 - Hydraulic pump
 - Lubrication hose or cartridge for the rear bearing



WARNING!

When removing the hydraulic cylinder, the piston rod must not twist 180°. The cylinder will not work properly if that occurs.

4.2. Attaching the frame



Attaching the frame of the propulsion unit to the boat:

1. Spread sealing compound (such as Sikaflex 221) on the fixing area (figure 20, point A).

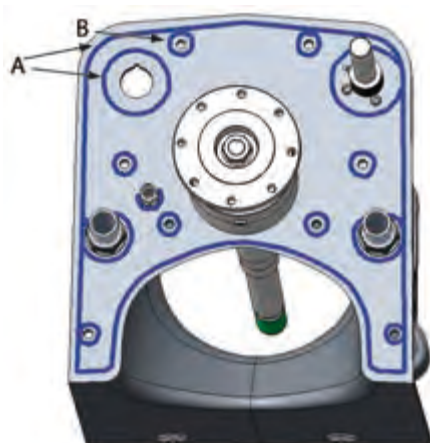

Figure 20. The frame of the propulsion unit

2. Put sealing compound in the fastening bolt holes (8 pcs) (figure 20, point B).
3. Lift the propulsion unit in place and push the fastening bolts in the holes.

Ask your assistant in the boat to fasten the nuts.

4. Tighten the nuts evenly on opposite sides and make sure that sealing compound squeezes out slightly on every side.

The tightening torque of the screws in reinforced plastic boats is 40 Nm, which is different from standard due to a softer base. Standard fastening is used in aluminium boats.

5. Wipe the burrs of sealing compound from the outer edges, intake duct and inside round the holes.

4.3. Installing the lubrication system for the bearing



4.3.1. Front bearing

The front bearing carries the axial and radial loads. The bearing is oil-lubricated and the housing is secured with mechanical sealing.

When the shaft rotates, the oil circulates through the reservoir and impurities gather at the bottom of the reservoir on the drain plug magnet.

The oil reservoir included in the system is installed in a suitable place. The need for maintenance (oil change) must be taken into consideration when selecting the location. It must be possible to check the oil level when necessary.

The bearing housing is filled with oil when it is delivered from the factory. The installation must be carefully performed in accordance with the instructions so that the lubrication functions well from the beginning and as little air as possible escapes into the system.

Installing the front bearing housing:

1. Make sure that the oil reservoir is installed (section 4.5. *Attaching the hydraulic pump*, page 29).

The bearing housing connectors are marked as IN and OUT (figure 21, A = IN and B = OUT). The corresponding oil reservoir connectors are marked in figure 34 (A = OUT and B = IN).

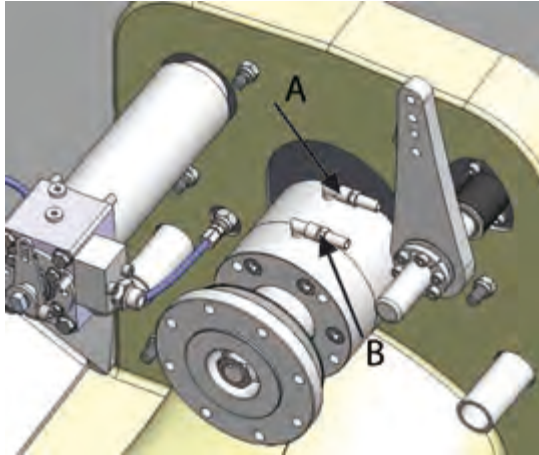

Figure 21. Bearing housing connectors

2. Remove the plug from the bearing housing IN connector, push the hose coming from the reservoir into place, and tighten the joint using pipe straps.
3. Pour oil into the reservoir and let the hose fill up for approx. 5 minutes. The type of oil to use is described in appendix 2. *Oil recommendations*, page 50.

Keep the hose as straight as possible and shake it occasionally to prevent air pockets from forming.

4. Remove the plug from the OUT connector and push the hose into place. Tighten the joint using pipe straps.

Keep adding oil into the reservoir so that as little air as possible drifts into the system.

5. Add oil to the reservoir until the oil level is between the markings on the dipstick (figure 22, points A and B).

The system generates slight pressure into the return line and the oil starts to circulate.



Figure 22. Oil level in the reservoir

4.3.2. Rear bearing

The bearing at the rear end of the shaft is lubricated from point A indicated in figure 23. The lubricant flows through the hoses and casting channels in the propulsion unit to the rear end bearing housing. A line is formed from point A to automatic lubrication with a plastic hose (B). Alternatively, there can be a grease nipple at the end of the hose.

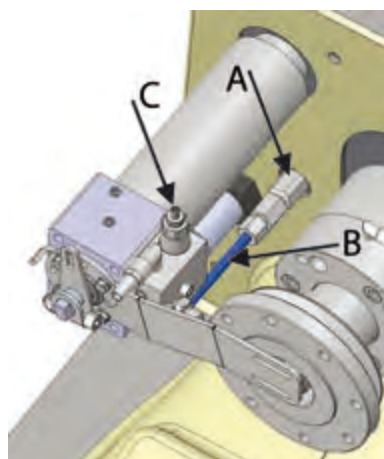

Figure 23. Rear end bearing grease tube

Note that during the propulsion unit installation the lubrication hose (B) is removed but it must be put back when the propulsion unit is in place.

The automatic lubrication unit (figure 24) decreases the need for maintenance because it feeds grease to the rear bearing each time the jet's main shaft

rotates. The grease going to the rear bearing lubricates the bearing, and it also prevents water from leaking into the bearing housing. The amount of grease is adjusted with a screw in the hydraulic cylinder which tightens the spring (figure 23, point C). When you loosen the screw, the amount of grease decreases.

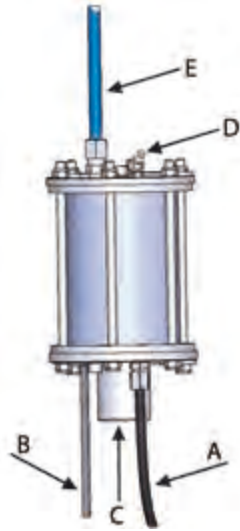

Figure 24. Automatic lubrication unit

A	Oil pressure hose from the hydraulic cylinder	D	Grease nipple
B	Scale	E	Grease hose to the lubrication channel
C	Piston		

Installing the automatic lubrication unit:

1. Choose an appropriate place near the propulsion unit.

Note the lengths of the oil pressure hose and the grease hose. The oil pressure hose (figure 25, point B) must not be tight. Also make sure that the piston (figure 25, point A) can move freely, as it protrudes the length of the scale when the reservoir fills up.

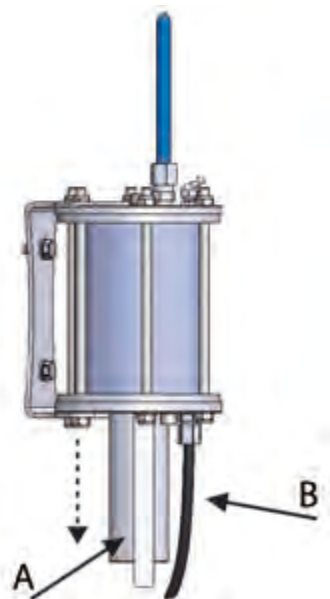

Figure 25. Automatic lubrication unit's piston movement range

2. Use the template delivered with the automatic lubrication unit to make holes for the fastening screws of the rack in a sufficiently sturdy place.
3. Attach the screws delivered with the automatic lubrication unit into place nearly all the way.
4. Put the rack in place.

The rack has slots for the screws. Slide the rack under the screws and tighten them (figure 26) with a spanner.

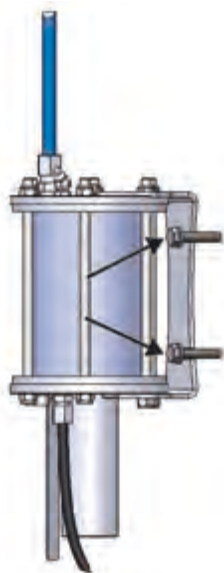

Figure 26. Automatic lubrication unit's tightening screws

5. Screw the oil pressure hose into either of the outputs shown in figure 27 and plug the unused output. Do not tighten excessively.

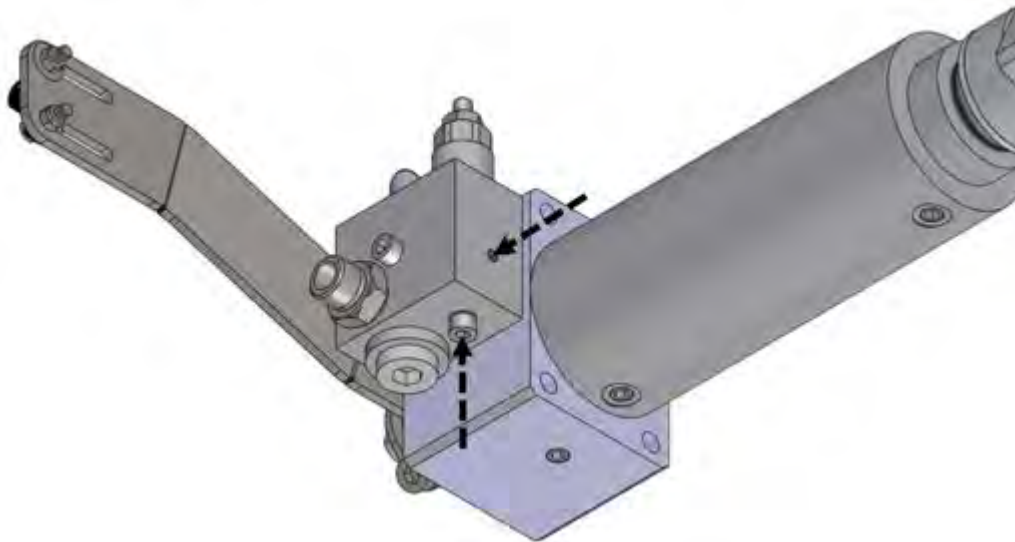

Figure 27. Attaching the oil pressure hose

6. Fit the grease hose to the nipple in the frame (figure 23, point A).

Feeding

You can adjust the feed as follows:

- If the automatic lubrication unit feeds too much grease (the reservoir empties too soon), reduce the pressure by loosening the adjusting screw (figure 23, point C).
- If the automatic lubrication unit does not feed grease to the rear bearing (cold conditions, thick grease type), increase the pressure by tightening the adjusting screw (figure 23, point C).

The amount of grease fed to the rear bearing must be 0.1 l/100 h (6 cu in/100 h). The grease volume in the unit is 0.3 l (18 cu in). With these settings, the reservoir empties after 300 hours. If you notice that the reservoir empties more quickly or slowly than this, adjust the pressure in the desired direction.

You can fill the reservoir by pushing grease into it with a grease gun through the nipple (figure 24, point D). Then the piston (figure 25, point A) will protrude out of the reservoir.

The properties of the grease to use are described in appendix 1. *Grease recommendations*, page 49.

4.4. Attaching the hydraulic cylinder



Attaching the hydraulic cylinder:

1. Make sure that the hydraulic cylinder goes in place without sealing compound.
2. Make sure that the key is in place (figure 28, point A).

The key ensures that the cylinder is in the right position and that the movement range remains correct.

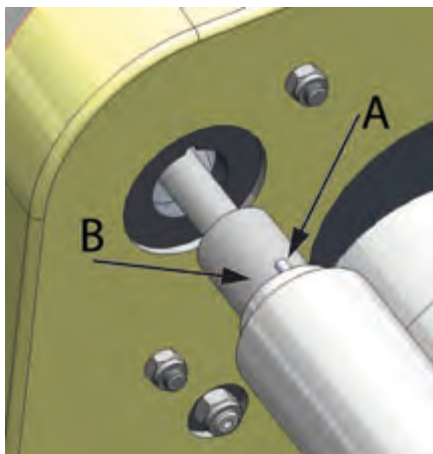

Figure 28. Hydraulic cylinder key

3. Spread sealing compound (such as Sikaflex 221) into point B, as indicated in figure 28 so that it seals the bushing.
4. Push the cylinder through the hole, insert the spacer (figure 29, point A) into its place, and tighten the screw (figure 29, point B).

The tightening torque for the large nut is 100 Nm (74 lb ft).

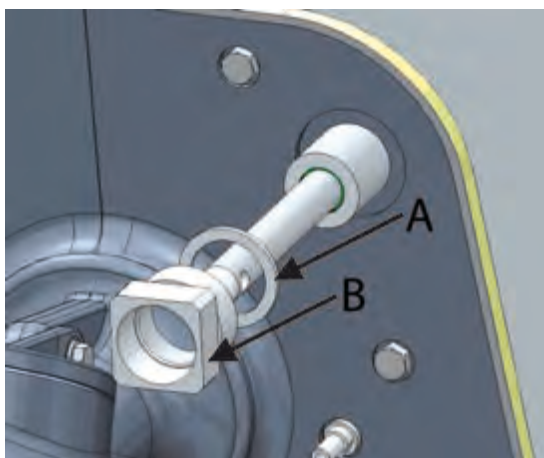

Figure 29. Hydraulic cylinder spacer and nut

There is a special tool available for screwing the nuts that can be used when the propulsion unit is embedded deep in the hull (figures 30 and 31).

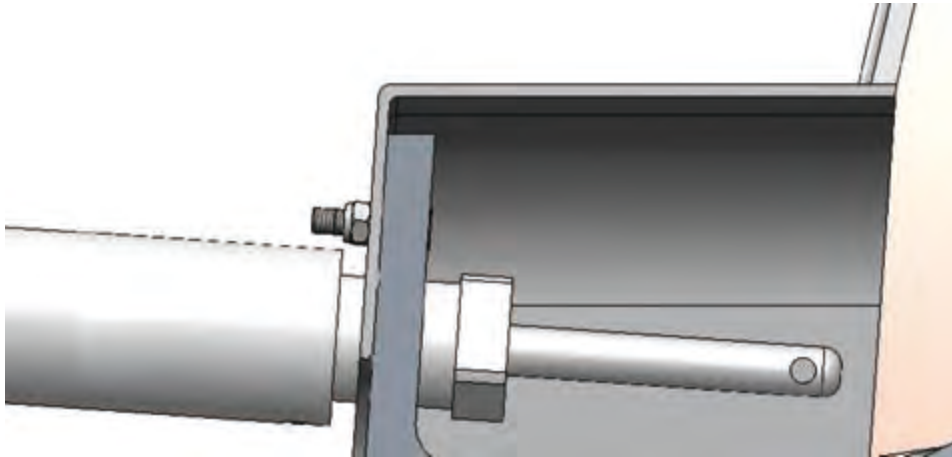

Figure 30. Propulsion unit embedded deep in the hull

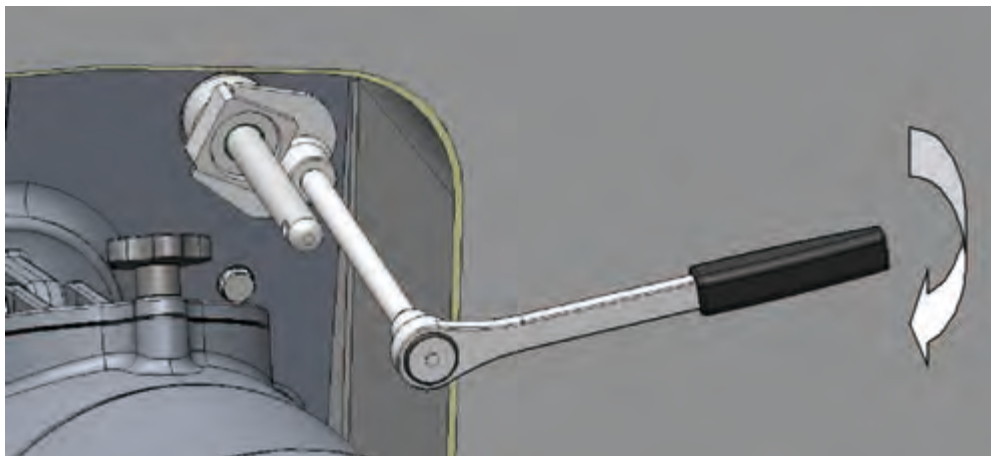

Figure 31. Special tool

5. Make sure that no sealing compound is on the piston rod.
If there is sealing compound on the rod, it must be wiped off.
6. After installing the reversing deflector, install the intermediate bar between the cylinder and the deflector (figure 32, point A).

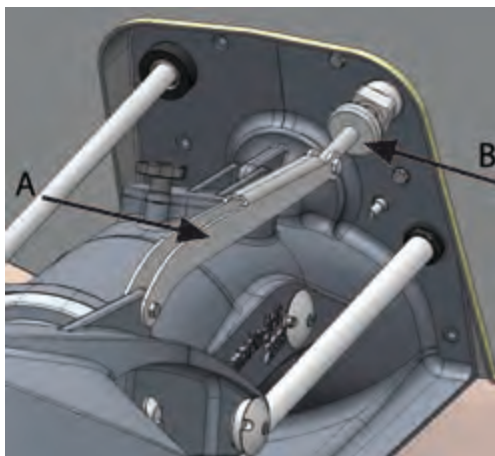

Figure 32. The intermediate bar between the hydraulic cylinder and the reversing deflector

7. Install the zinc anode to the piston rod.

Ensure that the zinc anode (figure 32, point B) does not prevent the deflector from moving all the way up.

4.5. Attaching the hydraulic pump



Attaching the hydraulic pump:

1. Install the pump bracket and the pump with screws to the front surface of the bearing housing.

Leave the screws slightly loose.

There are a total of four screws, two on each side (figure 33, points A and B).

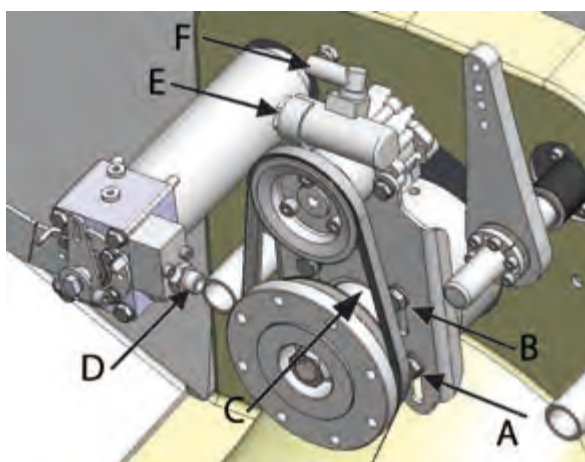

Figure 33. Attaching the hydraulic pump

2. Fit the belt in place.

3. Lift the bracket by cranking it from point C indicated in figure 33.
4. Tighten the screws.
The tightening torque is 46 Nm.
5. Install the pressure hose to connectors D and E (figure 33).
6. Install the reservoir hose to connector F (figure 33).
7. Install the oil reservoir bracket to a suitable place above the pump.



Figure 34. Oil reservoir and bracket

In figure 34, the 16 mm (5/8") connector (A) is intended for the hose that goes to the pump and the 12 mm (1/2") connector (B) for the return hose.

Checking the oil level

The system must have the right amount of oil. If you need to add oil to the system, add it in the oil reservoir through the cap (figure 35, point C). There is a dipstick on the reservoir cap with markings for maximum and minimum oil levels (figure 35). The type of oil to use is described in appendix 2. *Oil recommendations*, page 50.

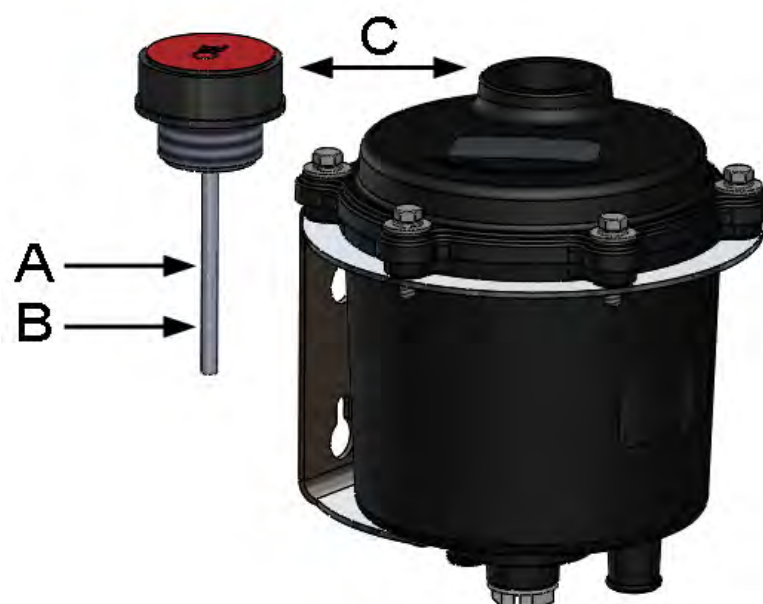

Figure 35. Checking the oil level

- A Maximum level
- B Minimum level
- C Cap

Amount of oil in the hydraulic system and the front bearing

Hydraulics:	1.3-1.7 L
Front bearing:	0.9-1.2 L

4.6. Installing the cooling line for hydraulic cylinder oil



WARNING!

The system's pressure is high during operation, max. 7 MPa (max. 70 bar).

Make sure that the hoses do not rub against sharp edges. The bursting of a pressure hose can cause serious danger.

The oil return hose must run to the reservoir through a cooler. For this, you can use a normal heat exchanger intended for oil cooling. The exchanger is installed to the engine's cooling water line after the raw water filter. The hydraulic return hose is only included in deliveries that include a heat exchanger.

**WARRANTY!**

If the cylinder oil is not cooled, the guarantee does not cover pump/cylinder failures due to overheating.

Figure 36 shows a basic picture of a cooling line.

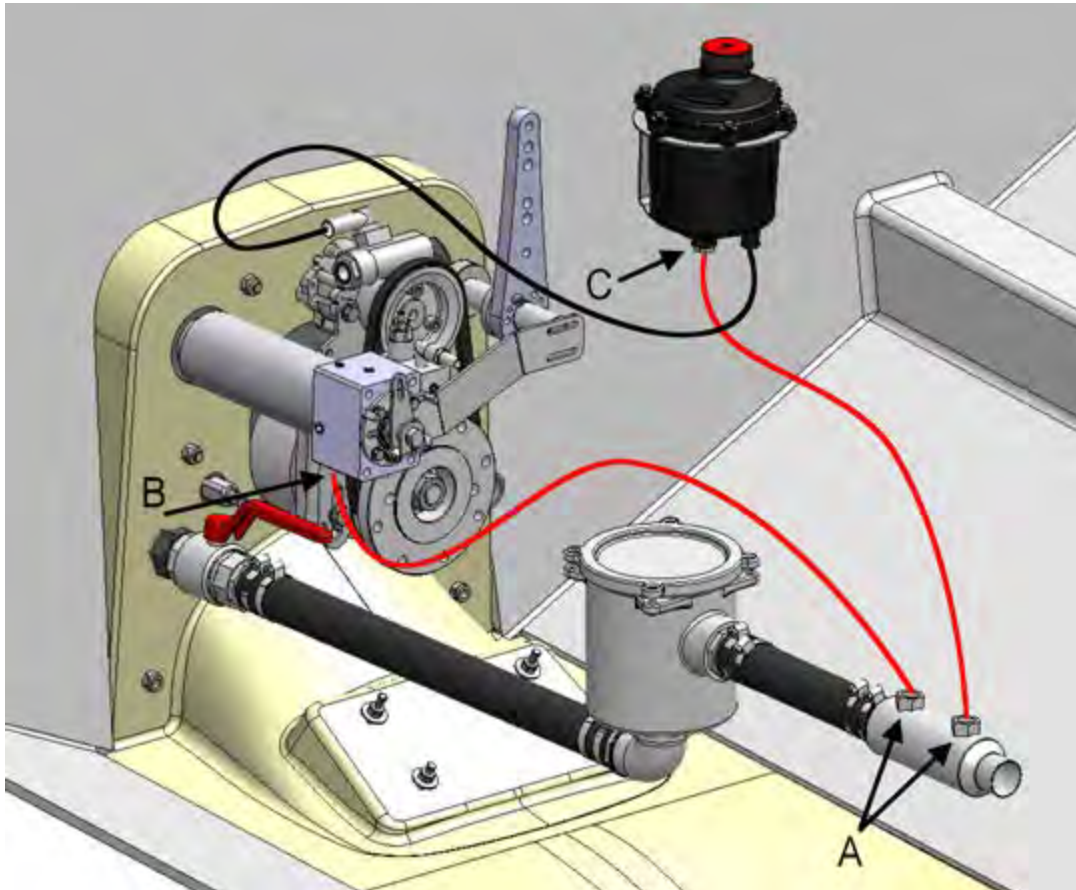

Figure 36. Cooling line

The hoses must run from the cooler connectors (figure 36, point A) to the cylinder's return connector (figure 36, point B) and the oil reservoir (figure 36, point C).

Note the following when installing the line:

- The cooler should be installed so that the inlet and outlet connectors point upwards. This advances the exit of air from the system.
- The hose that runs from the cooler to the reservoir should be fitted so that it does not have any "swan necks".

When you use the propulsion unit for the first time (=after engine installation), check the movement of the reversing deflector and observe the oil level. If the oil level continues to lower even after the line is filled, there is a leak in the system. Find the leak and fix the problem.

4.7. Attaching the intake screen



The intake screen (figure 37) is attached in front of the intake opening with four screws.

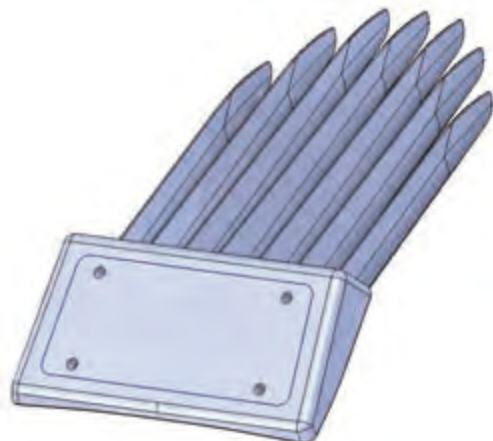

Figure 37. Intake screen

Attaching the intake screen:

1. Seal the fixing area in the same manner as when installing the propulsion unit frame.
2. Fit the intake screen in place in the intake duct and tighten the screws in place.

The normal tightening torque for an M8 screw is 23 Nm (17 lb ft). The tightening torque of the screws in reinforced plastic boats is only 20 Nm (15 lb ft).

4.8. Installing the raw water cooling line



Cooling water for the engine can be taken from the pressure face of the propulsion unit. The propulsion unit has two raw water intakes as standard equipment for this purpose. They are located on both sides of the bearing housing (figure 38).

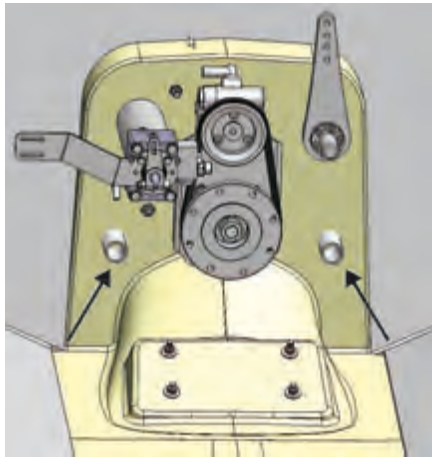

Figure 38. Raw water intakes

The intakes have a G1" external thread. The line to the engine can be constructed using normal pipe parts or can be plugged into the engine using the plugs delivered with the propulsion unit. The raw water intakes can also be used for other purposes that require pressure water.

The design pressure of the line is 10 bar, but the actual pressure depends on the impeller type, running speed and the line structure.

When constructing the raw water cooling line

- Note the engine manufacturer's recommendations regarding the cooling water feed.
- If necessary, throttle the line sufficiently before the engine and remove the throttles after the engine.

Line pressure should be measured before the engine, and the pressure should be adjusted in accordance with the engine manufacturer's instructions.

The hose joints must be durable enough. If the hose breaks or the joint comes off, the engine room may fill with water, the engine may break, or the boat may even sink.

Dry running of the jet (when the boat is not in water) can be performed without restriction.



CAUTION!

However, always observe the manufacturers' other instructions for dry running.

The operation of the raw water line is depicted in figure 39.

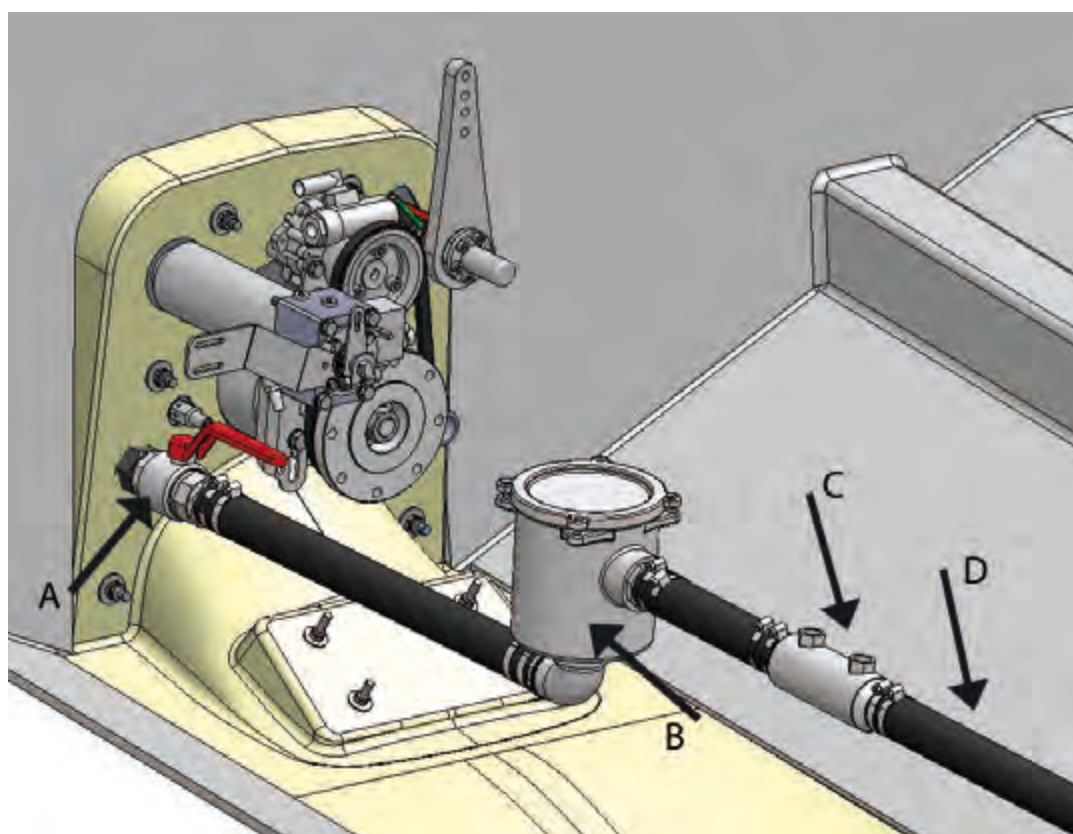

Figure 39. Raw water line

- A Water stop
- B Raw water filter
- C Cooler
- D Engine line

Note the following when installing the raw water cooling line:

- There must be a shut-off valve at the beginning of the line so that the line can be cut off when the boat is in water. If there is no valve, water will leak into the boat when the line is opened for cleaning, for example.
- The filter must be installed on the line before the coolers are installed. The filter must be above the waterline. (This way water does not flood in when the filter is being cleaned.)
- The line empties itself when the boat is on a horizontal plane (e.g. when the boat is hanging on a davit).



WARNING!

If the raw water line is not used at all, the line must be closed off carefully by means of the plug delivered with the jet.

If the line is not plugged, the engine room will fill with water.

5. Installing the control system

The propulsion unit's control system must be installed correctly. Incorrect installation of the system will reduce performance.

Because the propulsion unit can be used with or without gears, there are various methods of installation.

Installation Options

- The gear is located between the propulsion unit and the engine.

A control with two levers, one of which controls the gearbox and the accelerator and the other the reversing deflector.

- Between the propulsion unit and the engine, there is only the intermediate shaft.

A control with two levers, one of which controls the accelerator and the other the reversing deflector.

- Two propulsion units with a gear.

Two separate controls with two levers or one control with four levers. The two adjacent levers are used to control the gears and accelerators of both engines, and the other two to control the reversing deflectors.



WARNING!

The movement of the reversing deflector must always be controlled with a separate lever. Otherwise the propulsion unit does not function correctly.

5.1. Connecting the reversing deflector to the control system



The control cylinder of the reversing deflector is used with the lever (figure 40, point A) that is at the end of the cylinder. The lever has a cable terminal when it is delivered from the factory. However, the cable's inlet direction can be different than the standard direction of the cable support (figure 40, point B). You can turn the cable support plate to point in the desired direction in accordance with the cable's inlet direction.

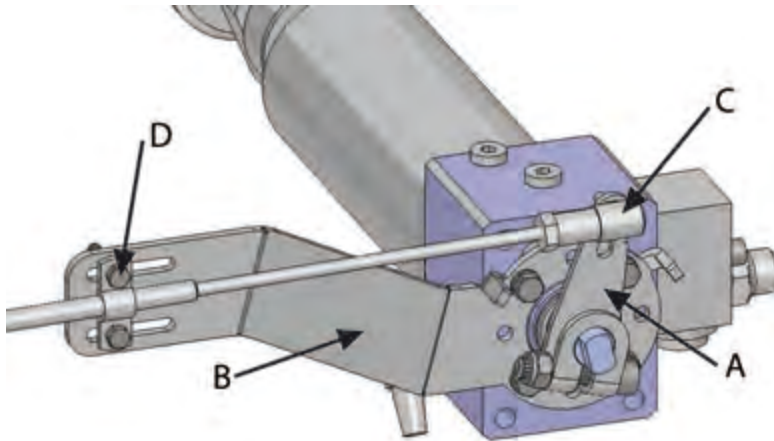

Figure 40. Hydraulic cylinder

Changing the position of the cable support:

1. If the control cable is attached, detach the end of the cable (figure 40, point C) from the cylinder's operating lever and detach the cable fastener from the support plate (figure 40, point D).
2. Loosen the operating lever's fastening screw and pull the lever off the shaft (figure 41).

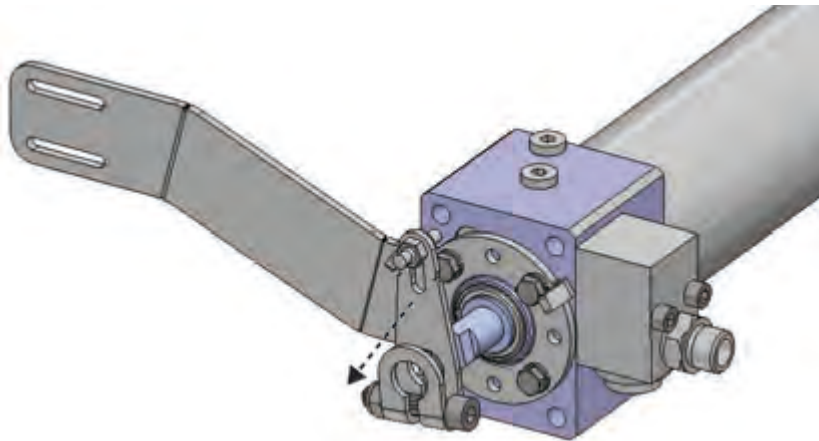

Figure 41. Removing the operating lever

3. Open the fastening screws (four in total, figure 42) that attach the support plate to the cylinder.

Note that the same screws attach the valve housing to the cylinder pipe. However, if you are careful the valve housing will remain in the cylinder pipe.

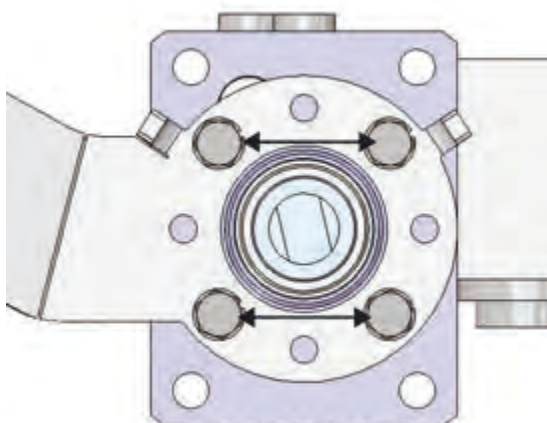

Figure 42. Support plate fastening screws

4. Turn the support plate into the desired position and attach it with screws to the valve housing (tightening torque: 10 Nm (7 lb ft)).

Check that the support plate or control cable do not interfere with the rotating intermediate shaft, for example.

The support plate has eight holes, so you can turn the plate at 45° intervals. In figure 43 the plate has been turned 135°.

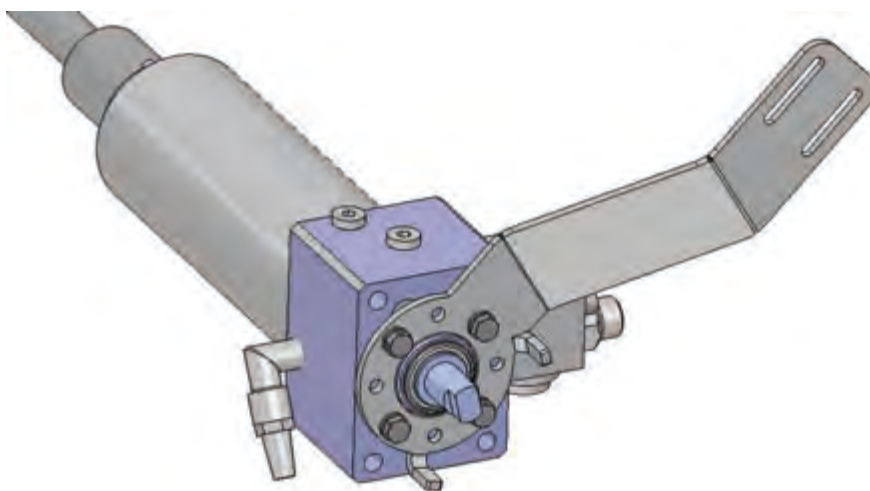

Figure 43. Turned support plate

5. Place the lever (figure 44, point A) on the operating shaft so that it lies between the limiters on the support plate (figure 44, point B).

The tightening torque of the lever screw is a non-standard 10 Nm (7 lb ft).

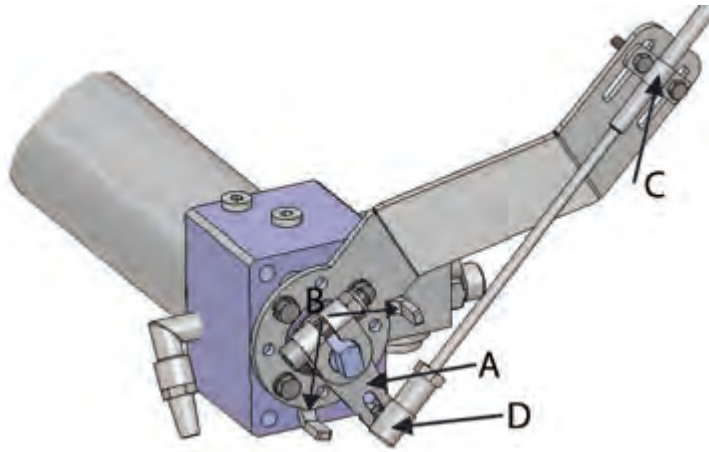

Figure 44. Attaching the operating lever

6. Attach the control cable with a fastener (figure 44, point C) to the support plate and with an angle joint (figure 44, point D) to the lever ball screw.

The height of the screw attachments at the end of the lever affects the control system stroke length. See appendix 9. *Lever movement ranges*, page 60.

See the cylinder adjustment instructions in section 5.1.2. *Cylinder adjustment*, page 41.

5.1.1. Connecting the control cables

The control cables are connected from the control system to the reversing deflector, as indicated in figures 45-47 .

Idle running

Both levers (B and C) are in the centre (figure 45)

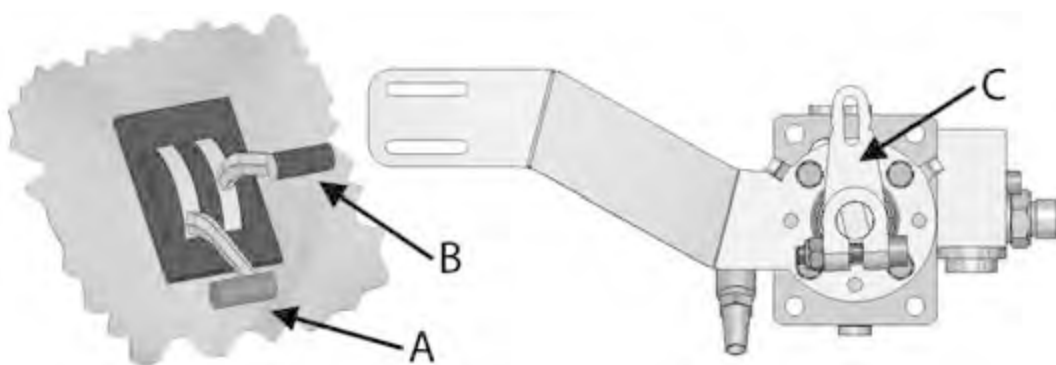

Figure 45. Idle running

- A Accelerator
- B Reversing deflector
- C Steering cylinder's operating lever

Full astern

The control lever is down, the cylinder operating lever on the left (figure 46)

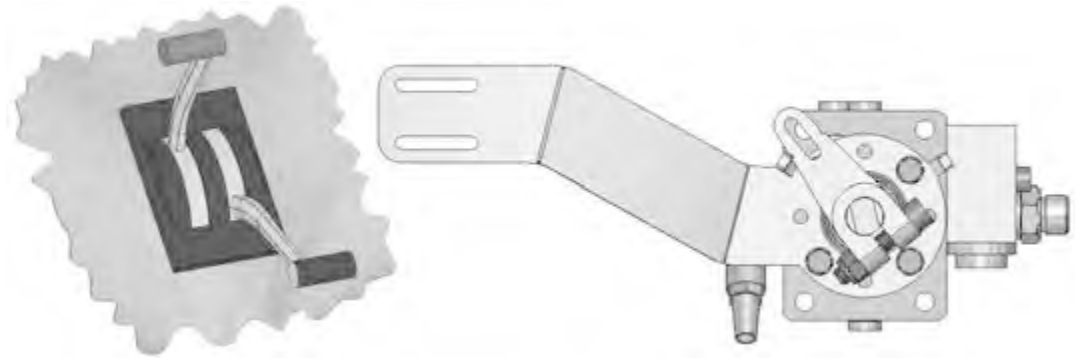

Figure 46. Full astern

Full ahead

The control lever is up, the cylinder operating lever on the right (figure 47)

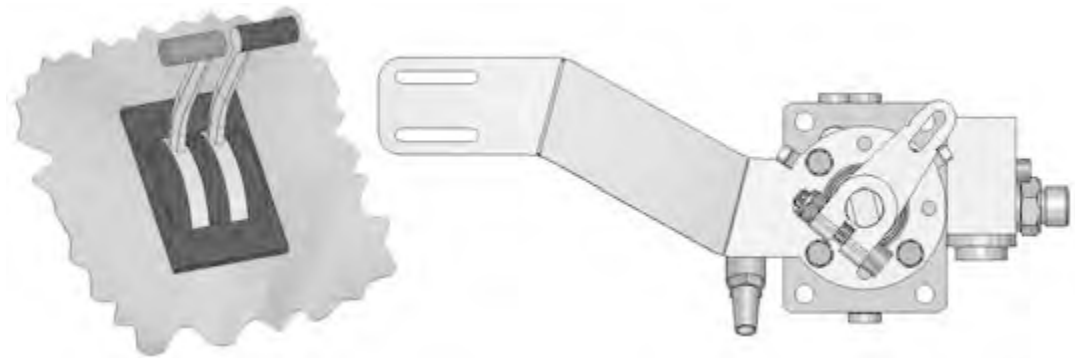

Figure 47. Full ahead

5.1.2. Cylinder adjustment

When you start the engine for the first time, make sure that you have oil available to add to the reversing deflector control hydraulic system.

Fill the reservoir with oil before you start the engine. After you start the engine and put it into forward gear, the oil is transferred from the reservoir into the system and the pump automatically removes air from the system. If the oil level decreases in the reservoir, add some oil. There is a dipstick in the reservoir that you can use to check the oil level (figure 35). Occasionally move the hydraulic cylinder's operating lever back and forth (figure 44, point A) so that the cylinder fills with oil.

Adjusting the cylinder:

1. Detach the control cable from the end of the cylinder operating lever (figure 48, point A).

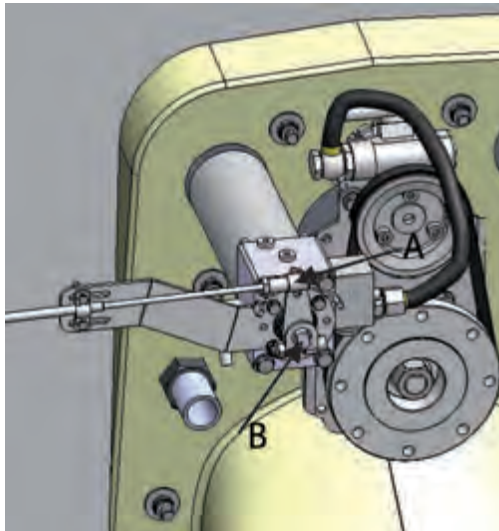

Figure 48. Removing the control cable

2. Loosen the operating lever screw (figure 48, point B) but do not pull the lever off the shaft yet.
3. Place the lever against the limiter on the shaft (figure 49, point A).

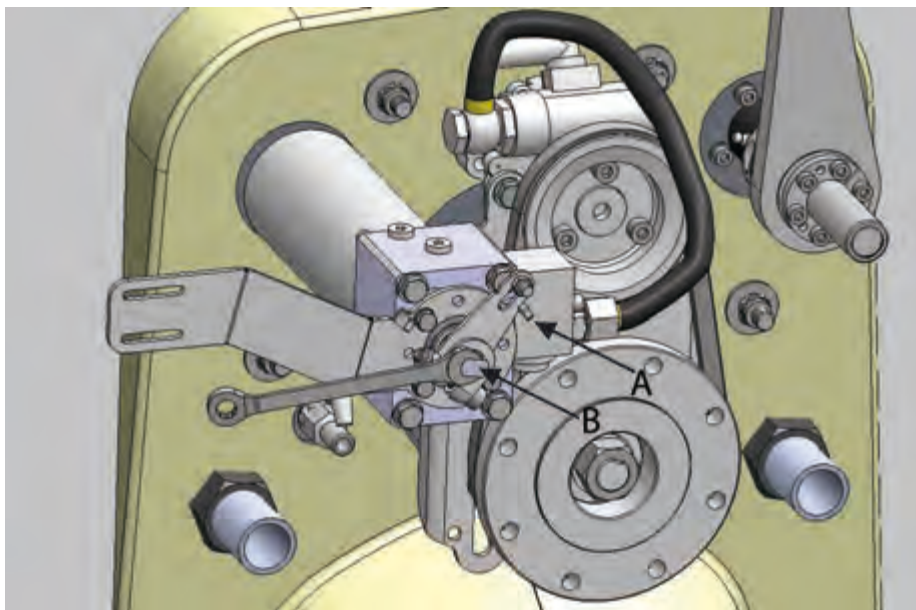

Figure 49. Operating shaft and limiter

4. Turn on the engine and put it into gear.
5. Using a wrench, turn the operating shaft (figure 49, point B) 13 mm (0.4") clockwise so that the reversing deflector is down, blocking the jet flow.

If you turn the shaft too much, it will no longer move smoothly, indicating that the cylinder has reached the end of its movement range. If this happens, turn the shaft back slightly.

6. Attach the operating lever to the shaft with a screw and tighten the screw to a torque of 10 Nm (7 lb ft).

Do not tighten the screw too much!

7. Attach the control cable to the screw at the end of the operating lever (figure 48, point A).
8. Use the control system in the cabin to check that the deflector can move to the up and down positions.

In the up position, the deflector does not block the jet flow (figure 50). In the down position, the top of the reversing deflector nearly touches the steering nozzle (figure 51).

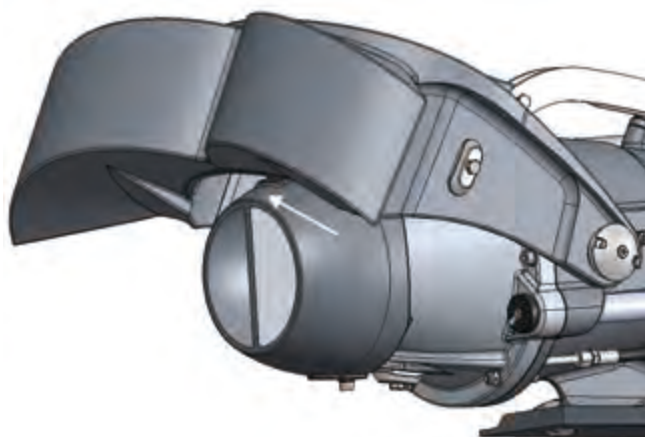

Figure 50. Deflector in the up position

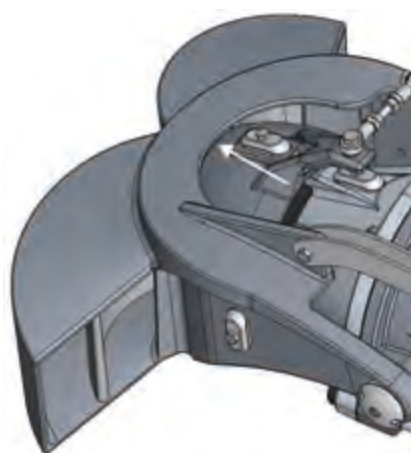

Figure 51. Deflector in the down position

5.2. Connecting the steering nozzle to the control system



There is a lever for the operating device at the end of the nozzle control shaft (figure 52). Operation can be hydraulic, electronic, or mechanical. The most important thing with the operation of the system is that the movement range of the operating device suits the movement range of the lever. The movement range of the lever has to be restricted in case the movement range of the operating device is too long.

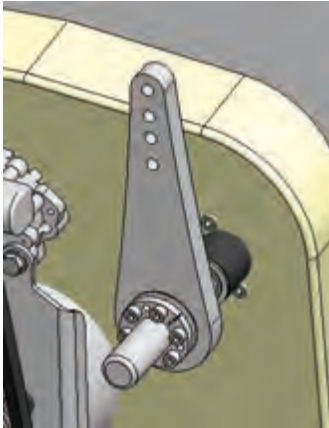

Figure 52. Operating device lever



WARNING!

If the movement range of the nozzle operating device is too long, the propulsion system can break down due to overload.

You can check the movement range with a special tool available as an accessory.

The control lever has holes ready at different heights so that different operating devices can be connected. See appendix 9. *Lever movement ranges*, page 60.

Connecting the lever to the shaft

1. Clean the surfaces of the shaft and the cone sleeve of grease.
2. Put some threadlocker on to the cone sleeve screws (6 pcs) and make them finger-tight. This way the lever can slide on the shaft and you can find the correct position for it.
3. Once you have found the correct position for the lever, tighten the lever on to the shaft with the cone sleeve. Tighten the cone sleeve screws evenly by tightening each screw in turn by several revolutions of the tightening ring while making sure that each screw is tightening the cone sleeve evenly.

Do not over-tighten the cone sleeve or the cone will stretch the outer ring of the lever. An excessively tightened cone will collapse and lose its grip.

In twin installation, the operating device is installed to the steering lever of one jet and the power is transmitted to the steering of the other jet with a connecting rod. The length of the connecting rod is determined by the distance between the jets (appendix 6. *Connecting rod for twin installation*, page 54).

6. Engine installation



This section deals with engine installation in relation to the propulsion unit. Otherwise, engine installation must always be carried out in accordance with the engine manufacturer's instructions.

The Alamarin-Jet AJ 288 propulsion unit can be used with various engines, either with gears or with a direct connection to the flywheel adapter. The gear is selected in accordance with the engine power and speed. Check the correct gear by contacting a representative of Alamarin-Jet Oy. Note the direction of the jet's rotation, which usually corresponds to the direction of the engine's rotation (counterclockwise from the rear of the boat).



CAUTION!

Before installing the engine, make sure that the gear possibly connected to it is correct. The wrong gear ratio decreases the performance of the propulsion unit or can completely prevent its use.

Aligning the engine with the propulsion unit

Correct sizing and aligning of the intermediate shaft is especially important for the operating life of the whole system. Different intermediate shafts allow different angles and it is imperative that you know the manufacturer's recommendations for maximum angles when installing.

Constant velocity shaft

At both ends of the constant speed shaft, there is a joint based on balls rolling on a spherical surface. Amongst the shafts used with propulsion units, an intermediate shaft of this type allows the most freedom in terms of alignment. The joints can be at angles that are different from each other (figure 53).

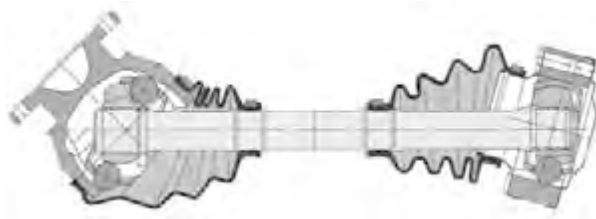

Figure 53. Constant velocity shaft

Cardan shaft

The cardan shaft joints are diagonal. This is why alignment is more demanding. To ensure that the shaft rotates without vibration, the joint angles must be equal. Figure 54 shows examples of allowed angle configurations.

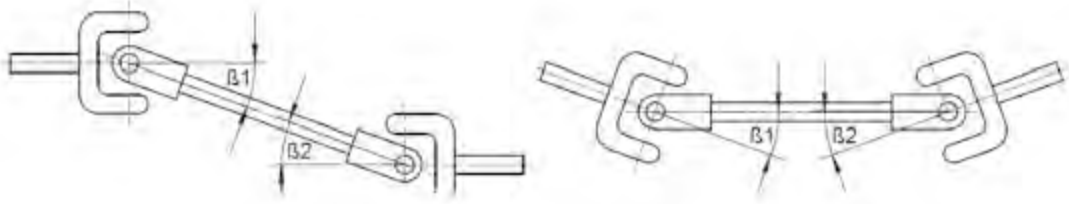

Figure 54. Cardan shaft

Intermediate shaft with rubber stop

Shafts with rubber stops effectively prevent vibrations that travel along the shaft to the hull of the boat. This is why they are particularly popular in boats with a metal structure. In the example shaft in figure 55 , there is a rubber joint at one end and a constant speed joint at the other.



Figure 55. Intermediate shaft with rubber stop



CAUTION!

Always ask the manufacturer of the intermediate shaft for installation and operation instructions and follow them carefully.

Installing the intermediate shaft

Note the following when installing the intermediate shaft:

- The shaft must be of such quality that it meets the general shaft-manufacturing standards. A poor-quality shaft may, for example, be balanced incorrectly, causing damage as it rotates.
- The ends of the shaft must be exactly in place against the flange surface before the screws are tightened. Incorrect position leads to wrong joint angle and unbalance. This may cause extensive damage to the system.
- The tightening screws of the intermediate shaft should be tightened a little at a time.



WARNING!

A rotating auxiliary shaft is dangerous. It must be protected with a detachable protector to prevent personal injury.

7. Antifouling



If the boat is going to be used in waterways where the growth and sticking of organisms around the boat's bottom and the propulsion unit is heavy, the propulsion unit can be painted with antifouling paint after installation.

Generally speaking, antifouling paints are based on various soluble substances, for example copper. Because the propulsion unit is made mainly of aluminium, copper forms a highly unfavourable galvanic couple with the propulsion unit. The aluminium starts to corrode because it functions as an anode.



WARNING!

If copper bearing antifouling paint is used for painting the propulsion unit, the result will be heavy corrosion and destruction of the propulsion unit.

Do not use any other antifouling paints for painting the propulsion unit except those intended for aluminium surfaces!

Instead, a boat bottom made of reinforced plastic can be painted using copper bearing antifouling paint. In this case, leave a 50 mm (2") unpainted area around the propulsion unit in the stern and on the bottom of the boat (figure 56).

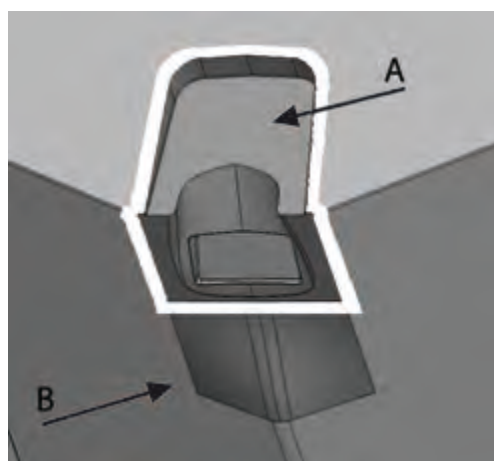

Figure 56. Antifouling

- A Unpainted area
- B Painted area



WARNING!

Zinc anodes and their fastening screws must not be painted with antifouling paint.

Appendix 1. Grease recommendations

The grease used for lubricating the propulsion unit bearing must meet the following requirements:

- lithium soap and a thickener with EP additives
- mineral oil as a base oil
- NLGI class 2
- operating temperature range -25 to 130°C (-13-266 °F)
- continuous operating temperature min. 75 °C (167 °F)

Recommended grease brands:

- Würth Multi-Purpose Grease III
- FAG Multi2
- FAG Load 220
- Mobil XHP 222
- Neste Allrex EP2
- Shell Retinax Grease EP2

A grease that has equivalent properties to those mentioned above can also be used for lubrication.

Appendix 2. Oil recommendations

The operating hydraulic system of the reversing deflector and the lubrication of the front bearing are designed to use oil that is specifically intended for automatic transmission systems. The oil must meet the following requirements:

Kinematic viscosity 40°C	33-36 mm ² /s
Kinematic viscosity 100°C	7.1-7.7 mm ² /s
Viscosity index	min. 170
Density 15°C	0.835-0.890 g/cm ³
Pour point	max. -42 °C
Flashpoint	min. 180 °C

Recommended oil brands:

- Mobil ATF 320
- FormulaShell ATF DEXRON III
- Neste ATF-X
- BP Autran DX III

Appendix 3. Tightening torques

Use the tightening torques from the table 2 when tightening the propulsion unit screws. The strength grade of an acid-proof A4-80 screw is equivalent to a class 8.8 screw.

Table 2. Tightening torques of the screws

	Strength grade		
	8.8	10.9	12.9
Thread	Tightening torque (Nm) (*)		
M5	5.5 (4)	8.1 (6)	9.5 (7)
M6	9.6 (7)	14 (10)	16 (12)
M8	23 (17)	34 (25)	40 (30)
M10	46 (34)	67 (49)	79 (58)
M12	79 (58)	115 (85)	135 (100)
M16	145 (107)	215 (159)	250 (184)

(*) The tightening torque in pound-feet (approximate value) is marked in the table in parentheses after the corresponding value in Nm.

A suitable thread locking compound that is good for all purposes is one of medium strength, for example. Loctite 242 or similar.

Appendix 4. Installation insert

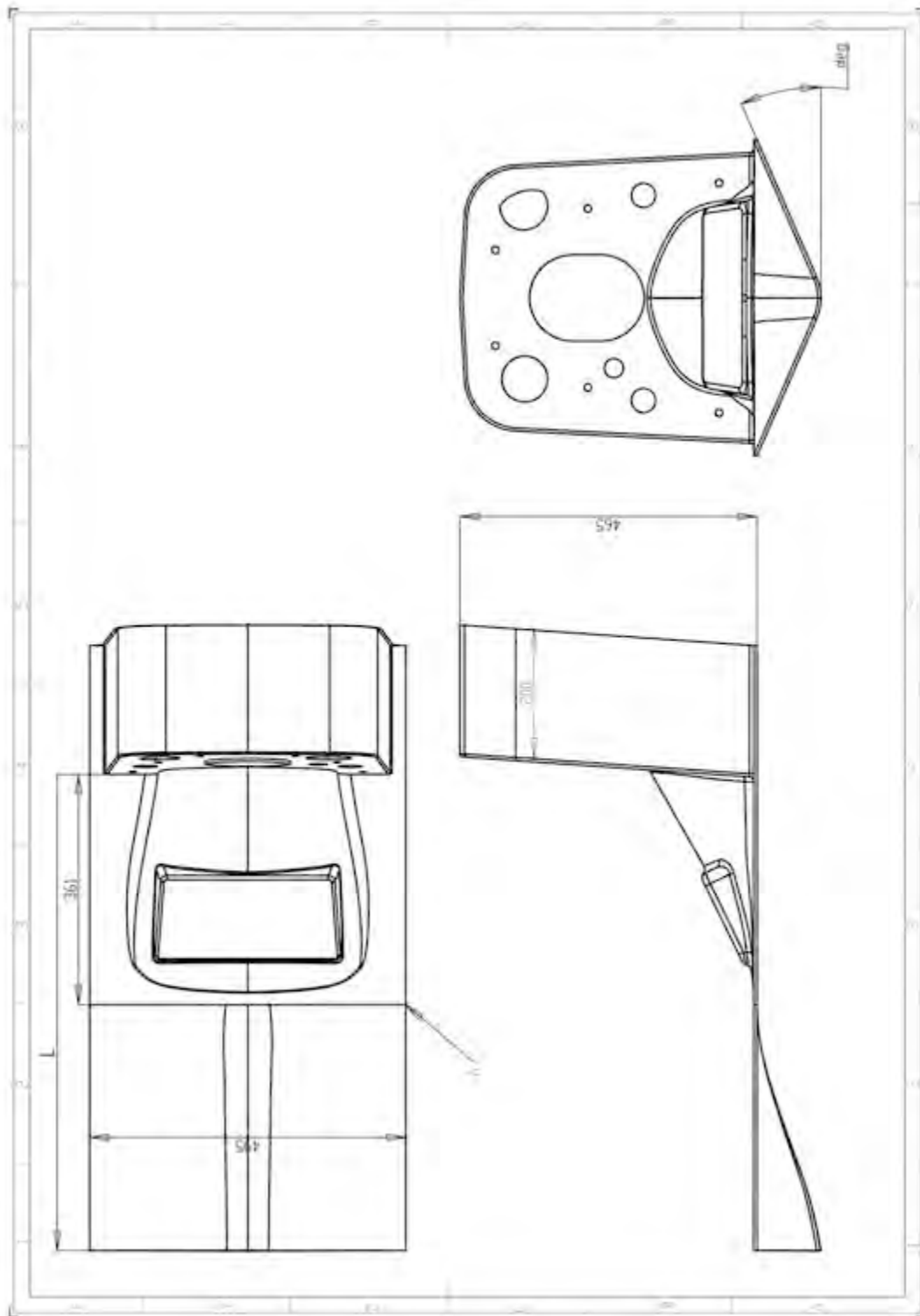

Appendix 5. Change in the v angle

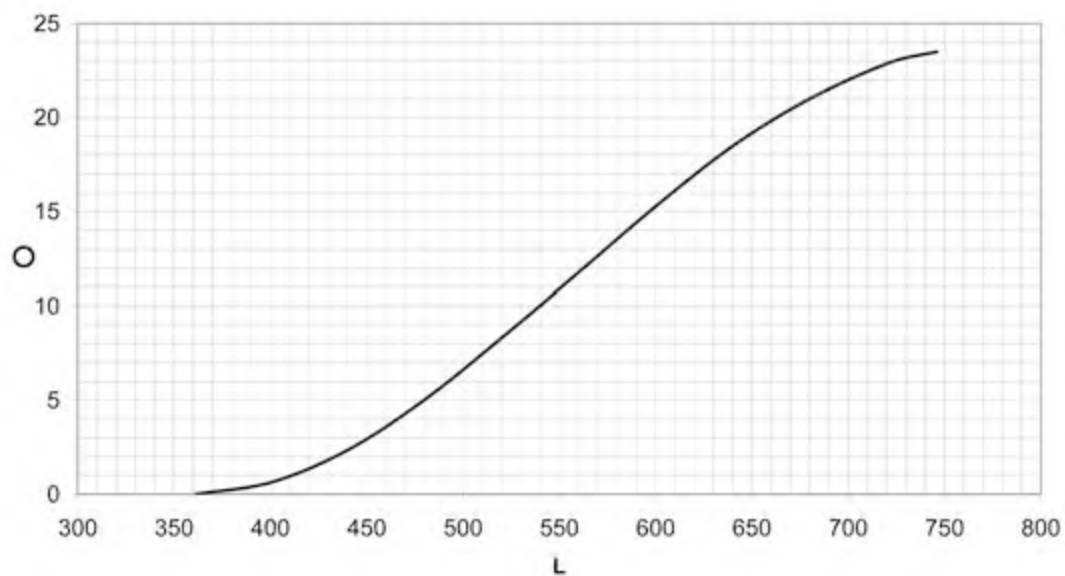
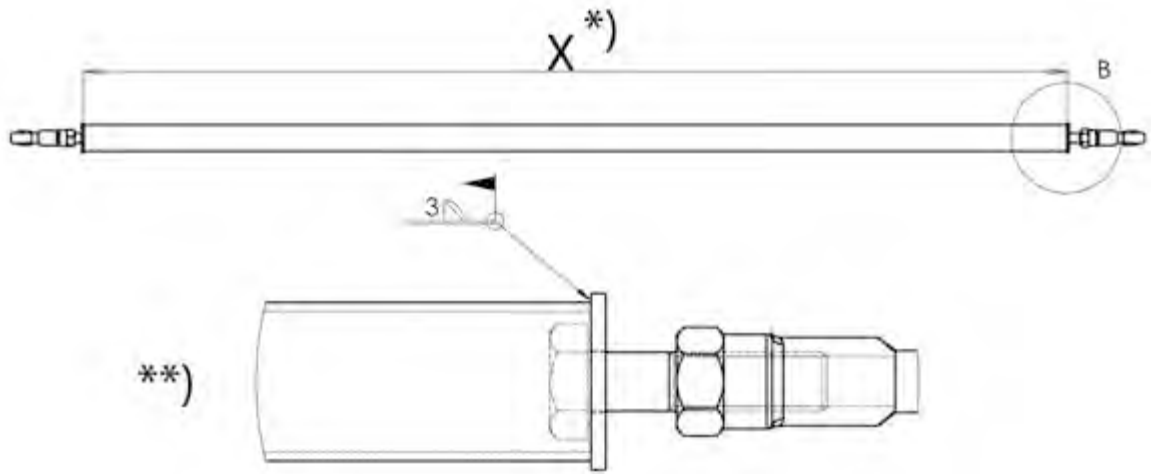

Figure 57. Change in the v angle

O Degree of the v angle

L Measurement in millimetres (1 mm = approx. 0.04")

Appendix 6. Connecting rod for twin installation



*) Measure x is determined by the distance between the jets.

***) Welding method TIG.

Materials to be welded EN 1.4436.

Appendix 7. Control system hydraulic line

Single installation with an automatic lubrication unit

Green Low-pressure hose
Red High-pressure hose
Blue Grease hose

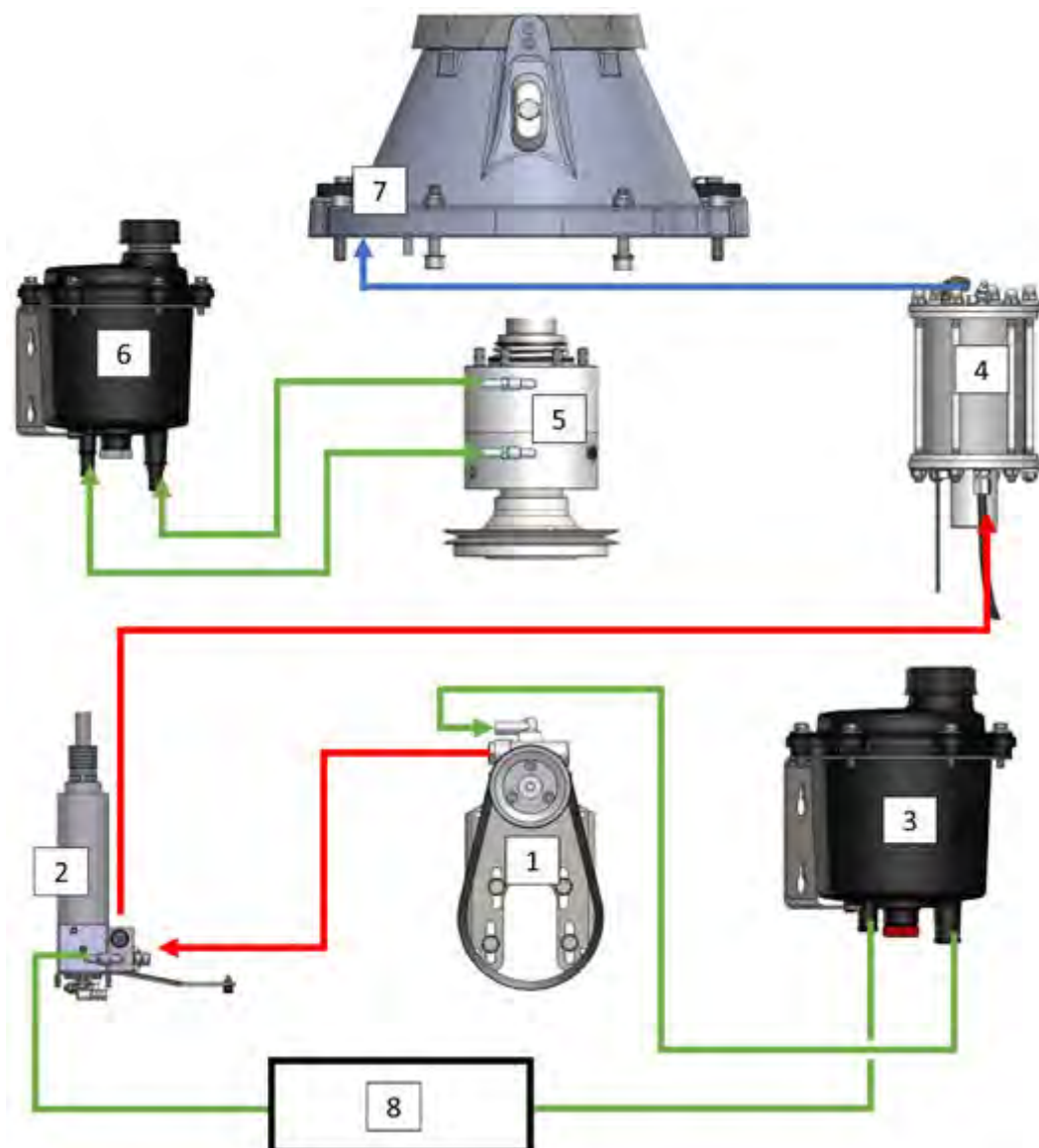

- | | | | |
|---|------------------------------|---|--|
| 1 | Oil pump | 5 | Bearing housing |
| 2 | Reversing deflector cylinder | 6 | Bearing housing oil reservoir |
| 3 | Oil reservoir | 7 | Rear bearing housing lubrication channel |
| 4 | Automatic lubrication unit | 8 | Oil cooler |

Single installation without an automatic lubrication unit

Green Low-pressure hose
Red High-pressure hose

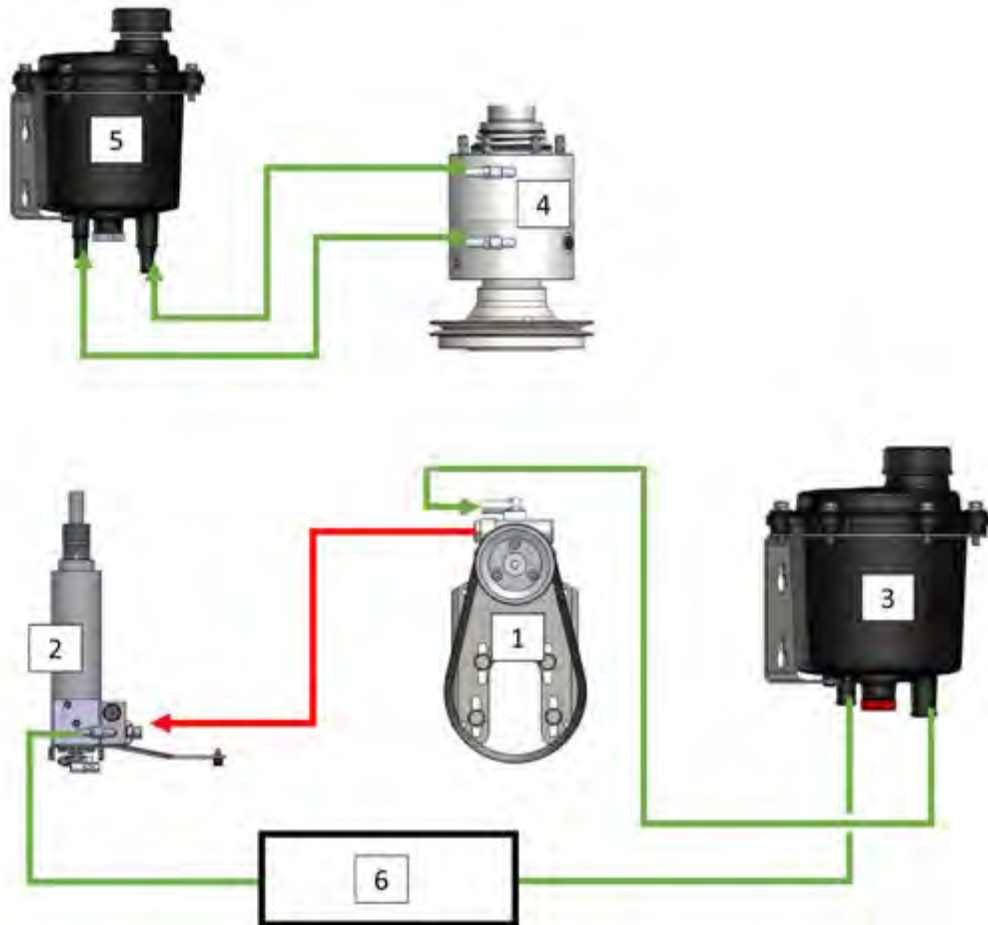

- | | | | |
|---|------------------------------|---|-------------------------------|
| 1 | Oil pump | 4 | Bearing housing |
| 2 | Reversing deflector cylinder | 5 | Bearing housing oil reservoir |
| 3 | Oil reservoir | 6 | Oil cooler |

Twin installation with automatic lubrication units

In a twin installation that includes automatic lubrication units, the hydraulic connections of both jets are made in the same way as in a single installation that includes an automatic lubrication unit.

Twin installation without automatic lubrication units

In a twin installation that does not include automatic lubrication units, the hydraulic connections of both jets are made in the same way as in a single installation.

Steering cylinder (optional) connections

Yellow Hose to the steering pump



1 Steering cylinder

Available steering nozzle control accessories are listed below

Code	Applicability
H2-018	Steering kit, single installation
H2-018D	Steering kit, twin installation
H2-041B and H2-041F	Steering kit with power steering, single installation
H2-041B, H2-041F, H2-041D and H2-008	Steering kit with power steering, twin installation

Appendix 8. Control systems

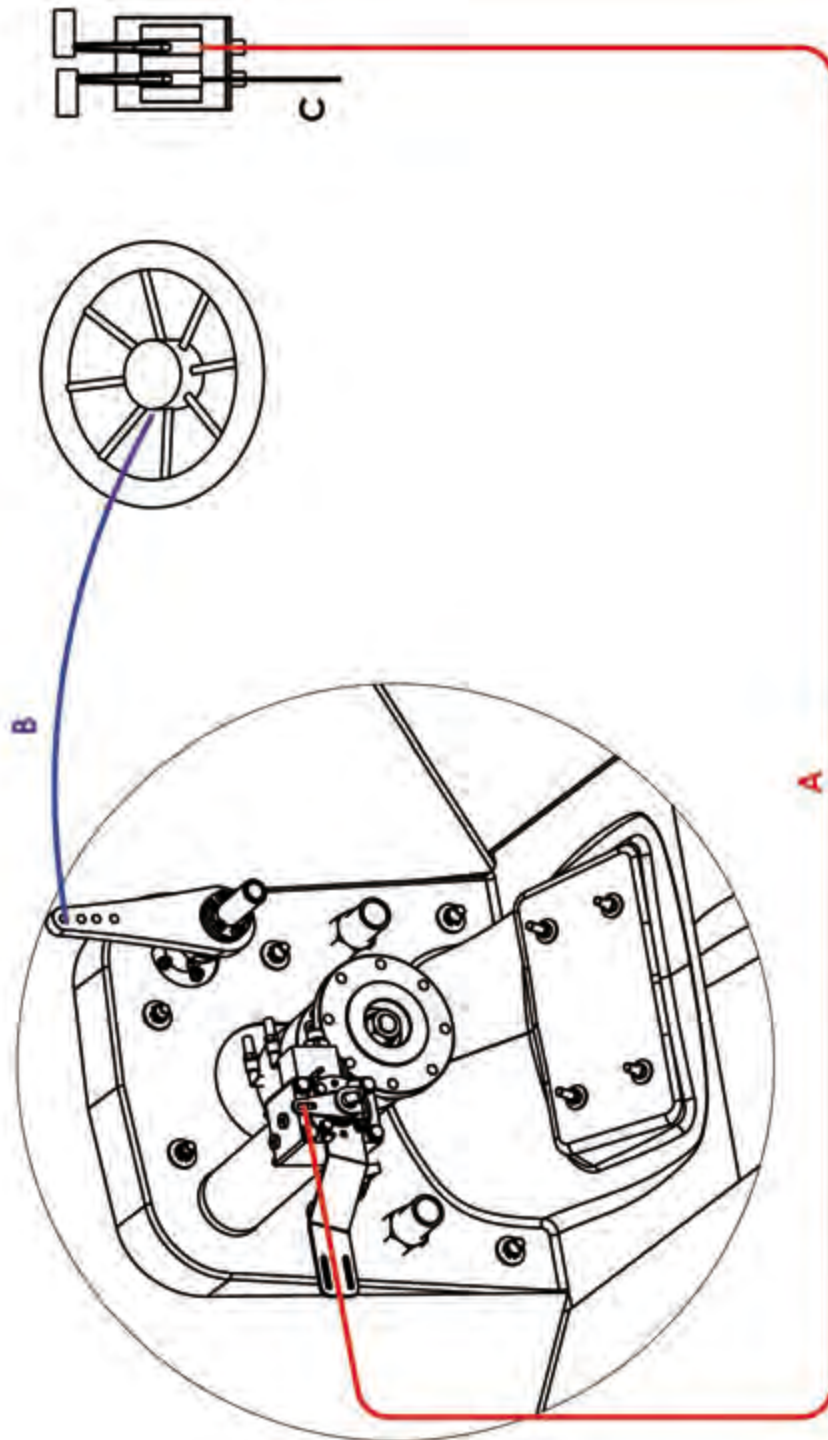

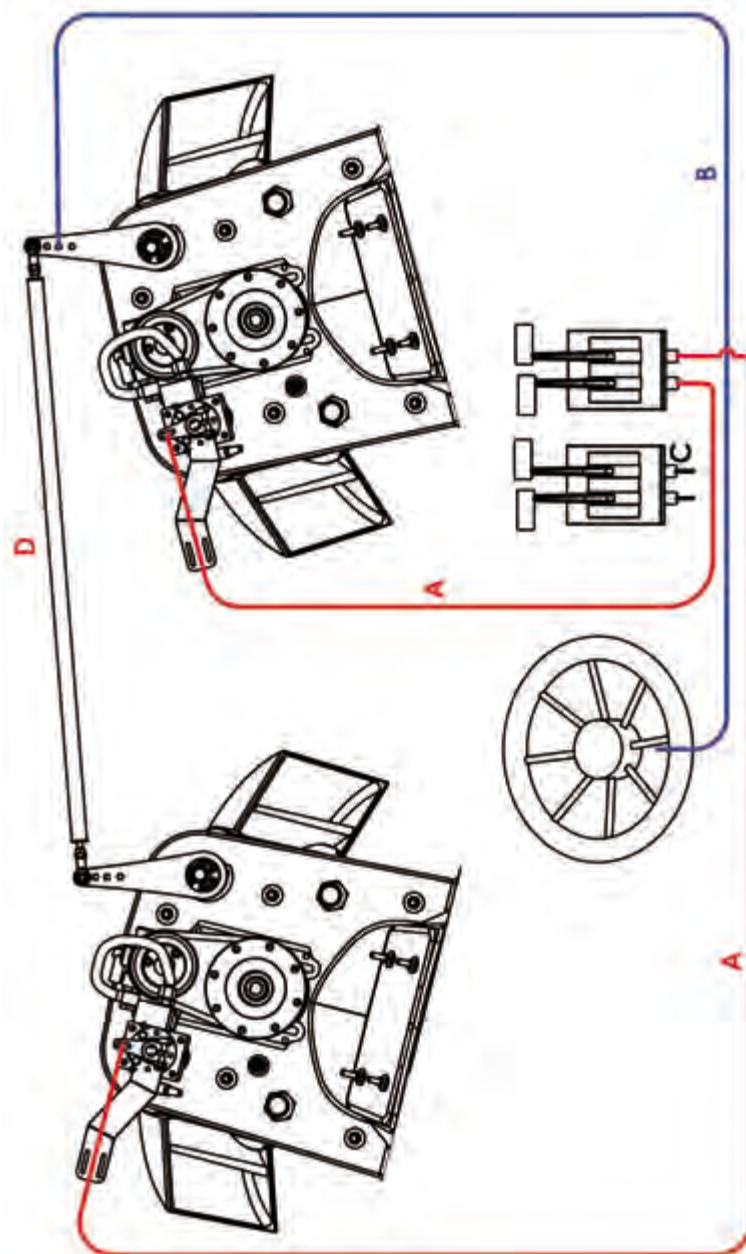

- A Reversing deflector's control cable
- B Steering device (cable or hydraulic)
- C Accelerator and gearbox control cables
- D Connecting rod for twin installation

Appendix 9. Lever movement ranges

Steering lever

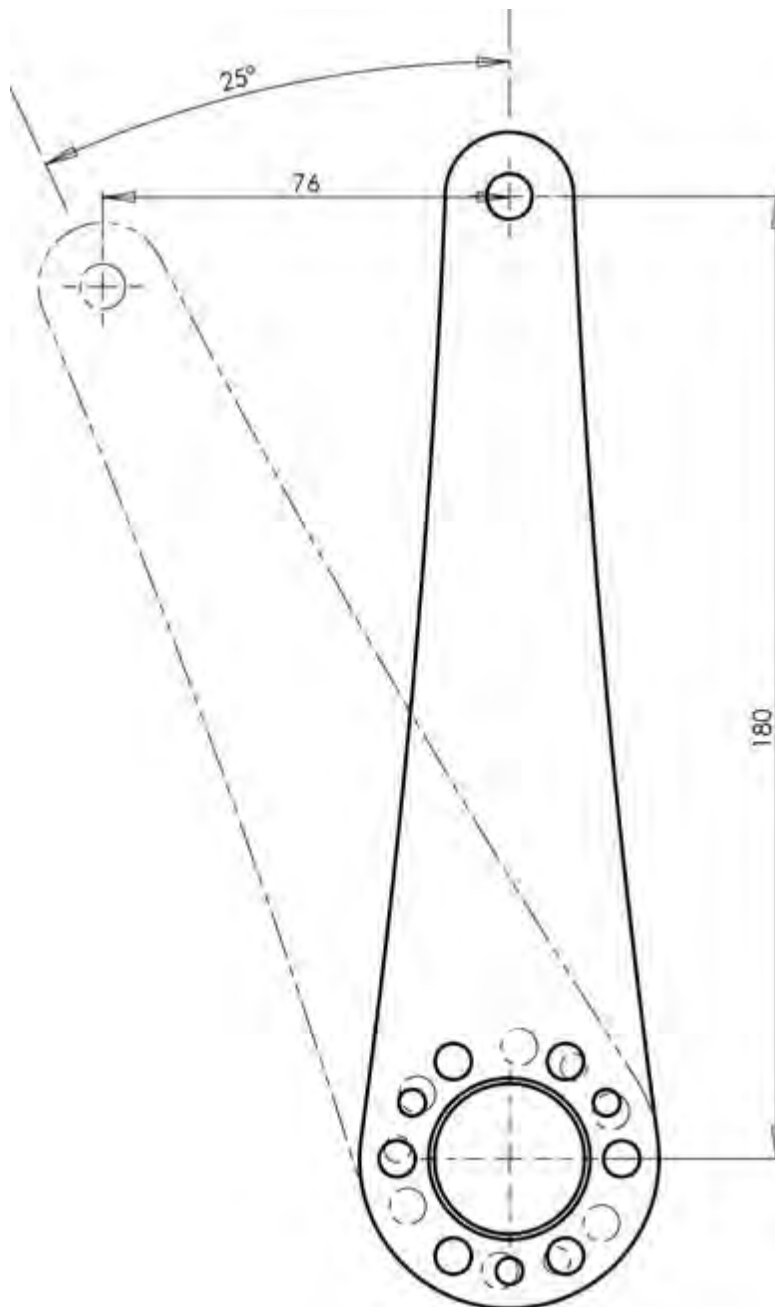

The maximum rotating angle for the lever is 25°. The steering device's maximum stroke length is 152 mm (5.9"). If the steering device's stroke is longer than this, it must be limited or the system may be damaged.

Lever holing may vary. Please contact the manufacturer if you need more detailed information.

Hydraulic cylinder control lever

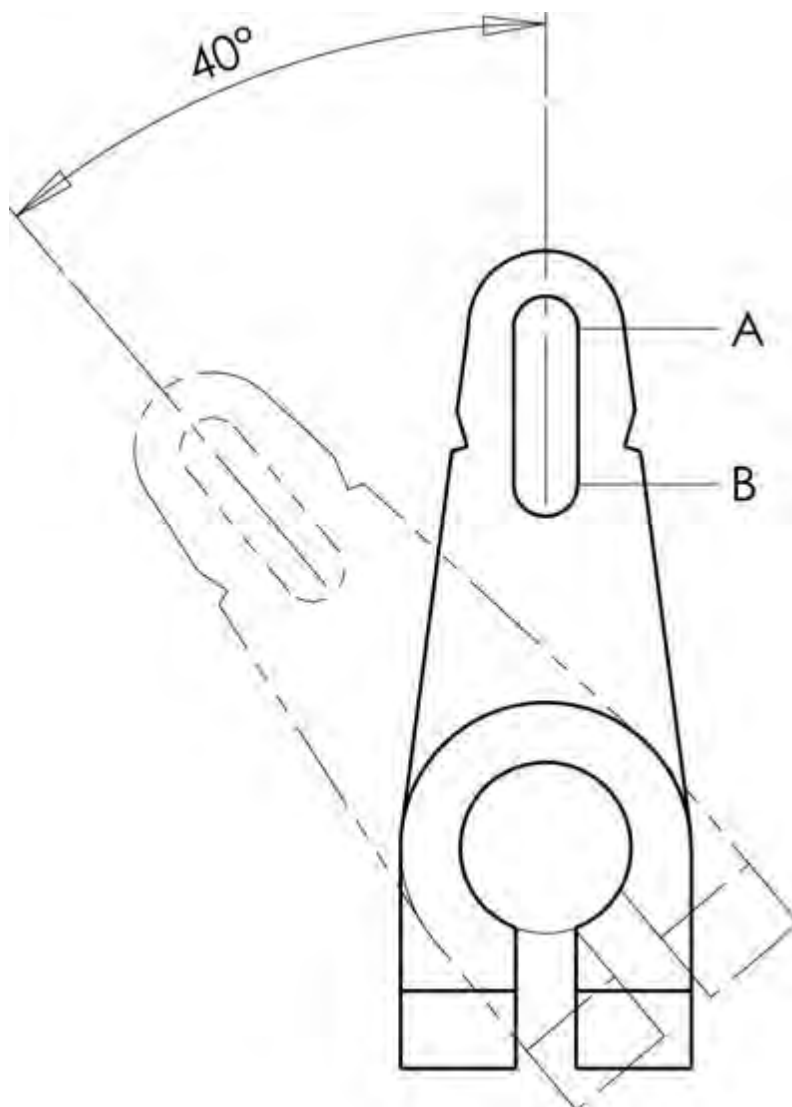

The length of a full stroke in point A is approx. 64 mm (2.5").

The length of a full stroke in point B is approx. 46 mm (1.8").

