

THE INFORMATION CONTAINED HEREIN IS CONFIDENTIAL AND PROPRIETARY TO ALAMARIN-JET AND IS NOT TO BE REPRODUCED, MODIFIED OR USED WITHOUT PRIOR PERMISSION OF ALAMARIN-JET OR ITS DULY AUTHORIZED REPRESENTATIVE. ALL RIGHTS RESERVED.

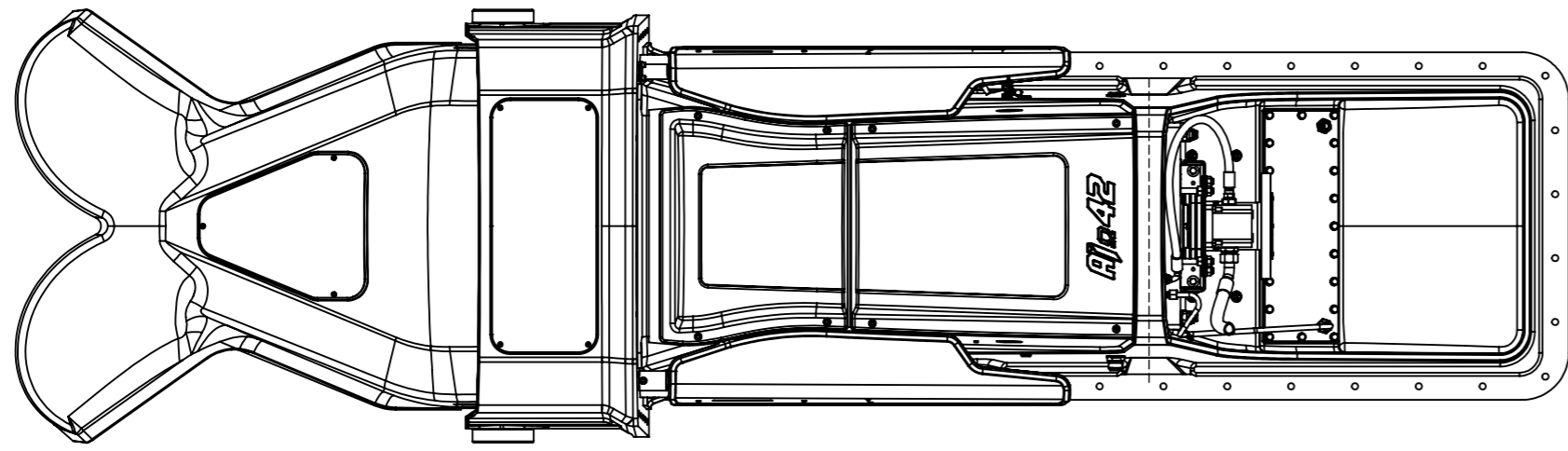
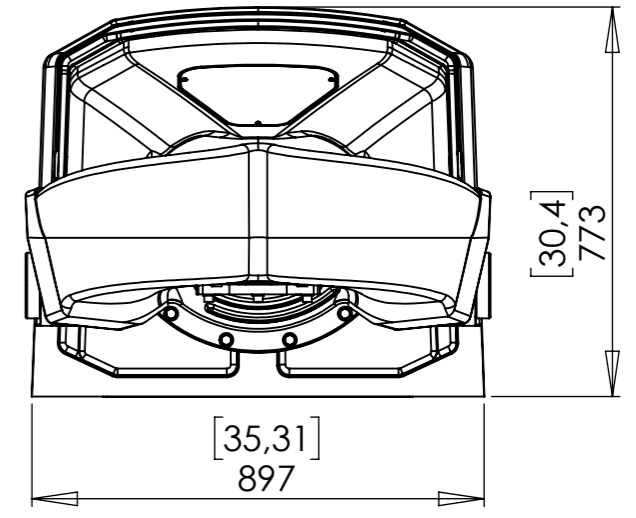
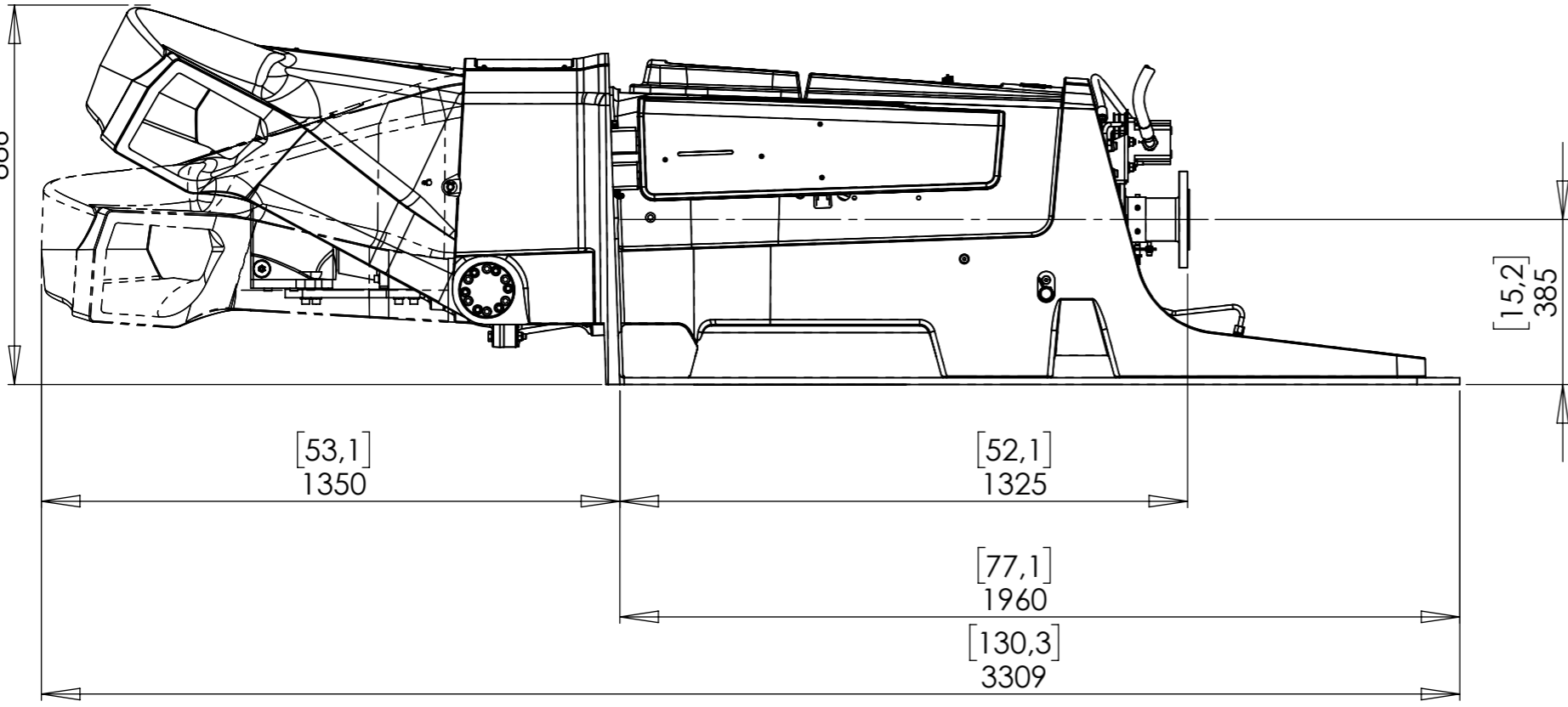

Technical data

Max. power	1500kW/2040hp
Max . rpm	2300 1/min
Max. torque	6,3kNm
Impeller diameter	480mm (18.9")
Unit weight*	815kg (1797lbs)
Entrained water**	171L

* In air. For trim/draft calculations lower values must be used
 **Volume inside the unit within the boat hull (loss of buoyancy)

Dimensions may change without prior notice Dimensions [imperial]
metric

Muutos / Change Suunnittelija / Designed Hyväksyjä / Approved by

Work Tolerances:
 Machining SFS4011 (ISO2768) middle
 Welded structures SFS3393-B length and angles
 Form and orientation tolerances DIN8570BL3 - E
 castings SFS-ISO8062

Surface treatment	Surface area [m²]	Mass [kg]	Designer	08.01.2019
Colour		0.00	VKa	
		ISO	Approved	
Product code			Version	
Q42			Q42	
0-degrees shaft angle			Size A3	Scale 1:15 Page 1/5



THE INFORMATION CONTAINED HEREIN IS CONFIDENTIAL AND PROPRIETARY TO ALAMARIN-JET AND IS NOT TO BE REPRODUCED, MODIFIED OR USED WITHOUT PRIOR PERMISSION OF ALAMARIN-JET OR ITS DULY AUTHORIZED REPRESENTATIVE. ALL RIGHTS RESERVED.

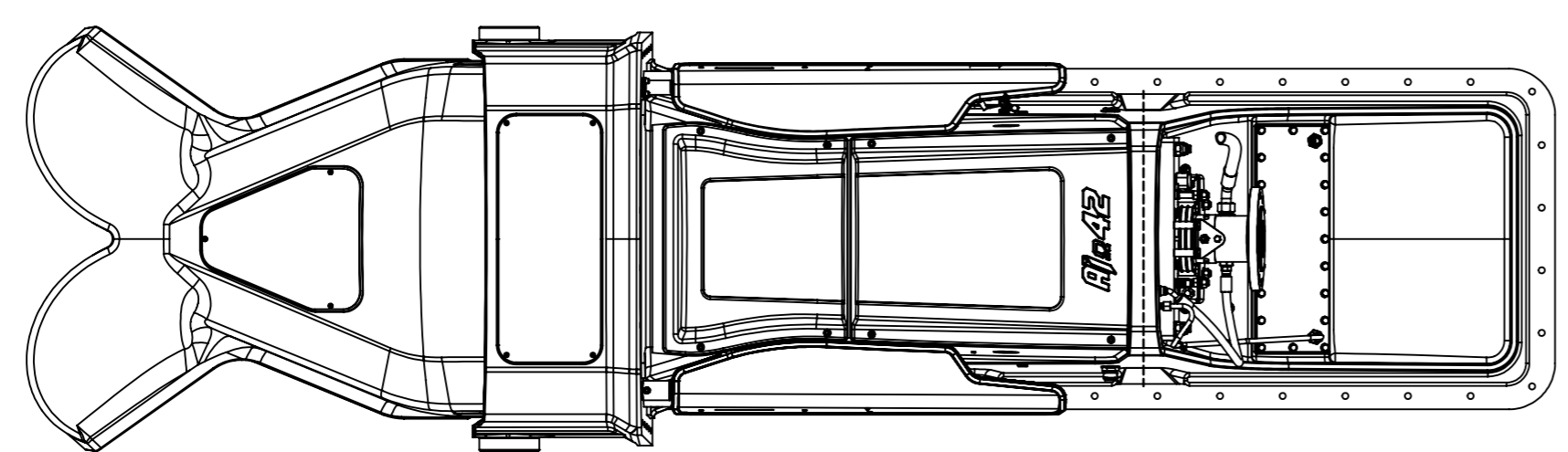
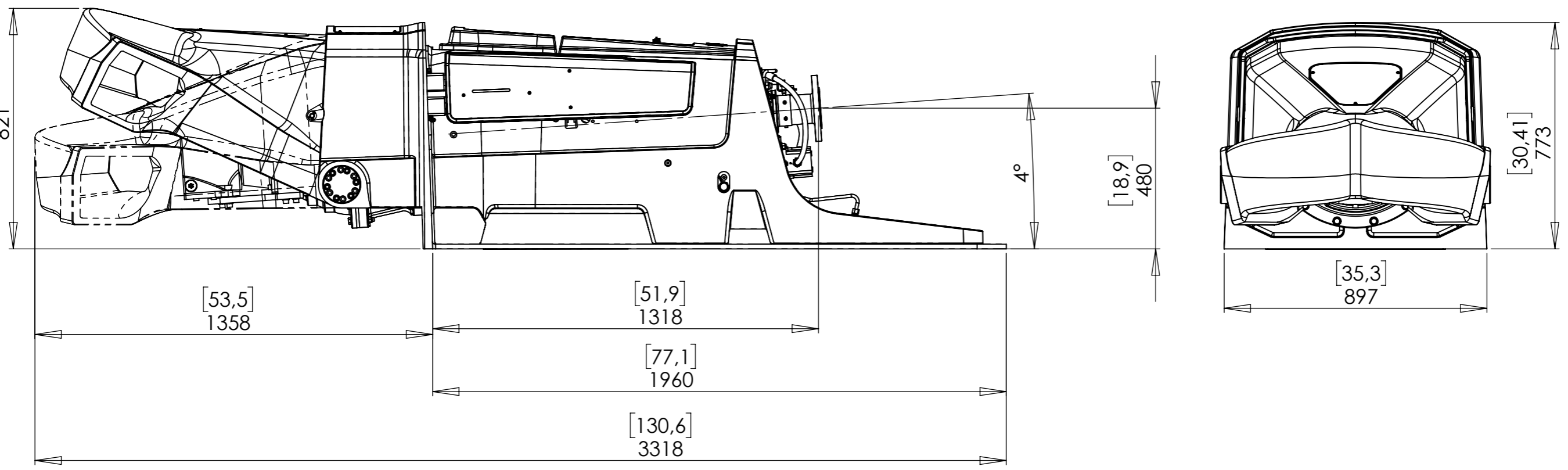

Technical data

Max. power	1500kW/2040hp
Max . rpm	2300 1/min
Max. torque	6,3kNm
Impeller diameter	480mm (18.9")
Unit dry weight*	815kg [1797lbs]
Entrained water**	171L

* In air. For trim/draft calculations lower values must be used
 **Volume inside the unit within the boat hull (loss of buoyancy)

Dimensions may change without prior notice Dimensions [imperial]
metric

Muutos / Change Suunnittelija / Designed Hyväksyjä / Approved by

Work Tolerances: Machining SFS4011 (ISO2768) middle Welded structures SFS3393-B length and angles Form and orientation tolerances DIN8570BL3 - E castings SFS-ISO8062	Surface treatment	Surface area [m ²]	Mass [kg]	Designer	VKa 08.01.2019
	Colour		0.00	Approved	
ALAMARINJET Ω42 4-degrees shaft angle			Product code	Version	
			Ω42		
Size A3		Scale 1:15	Page 2/5		