

THE INFORMATION CONTAINED HEREIN IS CONFIDENTIAL AND PROPRIETARY TO ALAMARIN-JET. IT IS NOT TO BE REPRODUCED, COPIED, OR TRANSMITTED IN ANY FORM OR BY ANY MEANS, ELECTRONIC OR MECHANICAL, INCLUDING PHOTOCOPYING, RECORDING, OR BY ANY INFORMATION STORAGE AND RETRIEVAL SYSTEM, WITHOUT THE WRITTEN PERMISSION OF ALAMARIN-JET OR ITS DULY AUTHORIZED REPRESENTATIVE. ALL RIGHTS RESERVED.

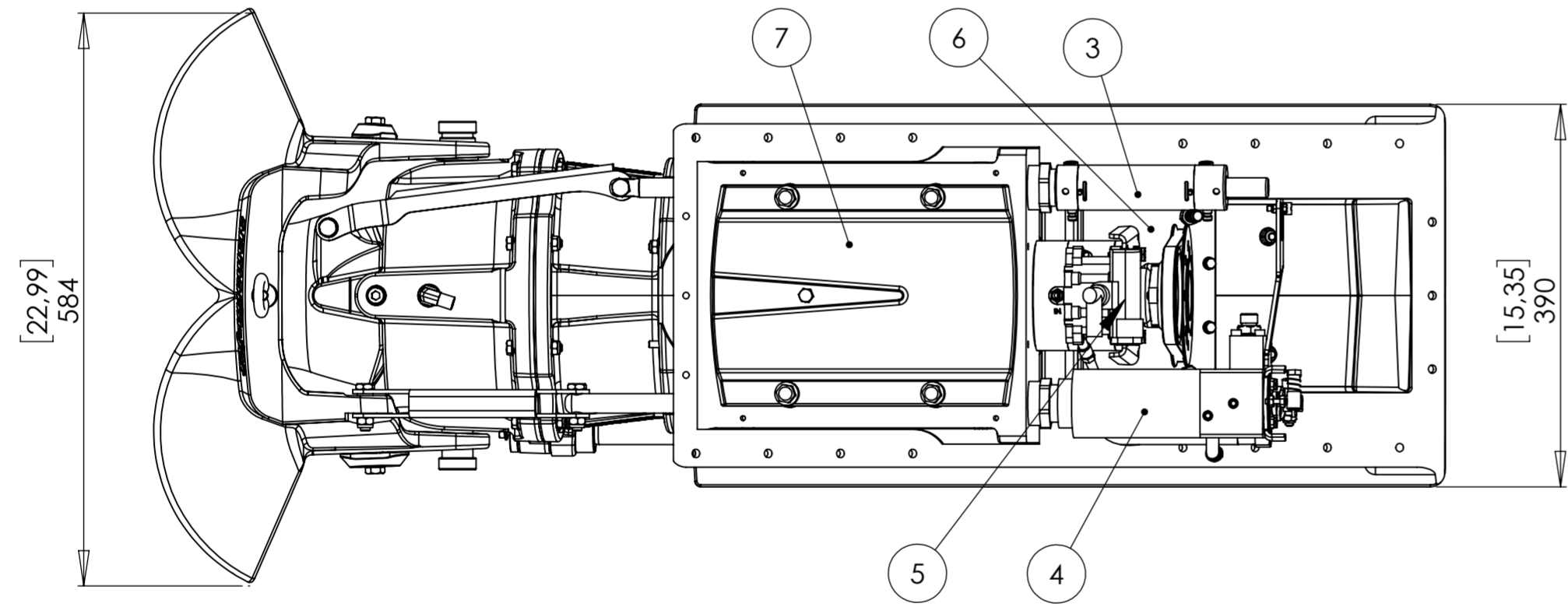
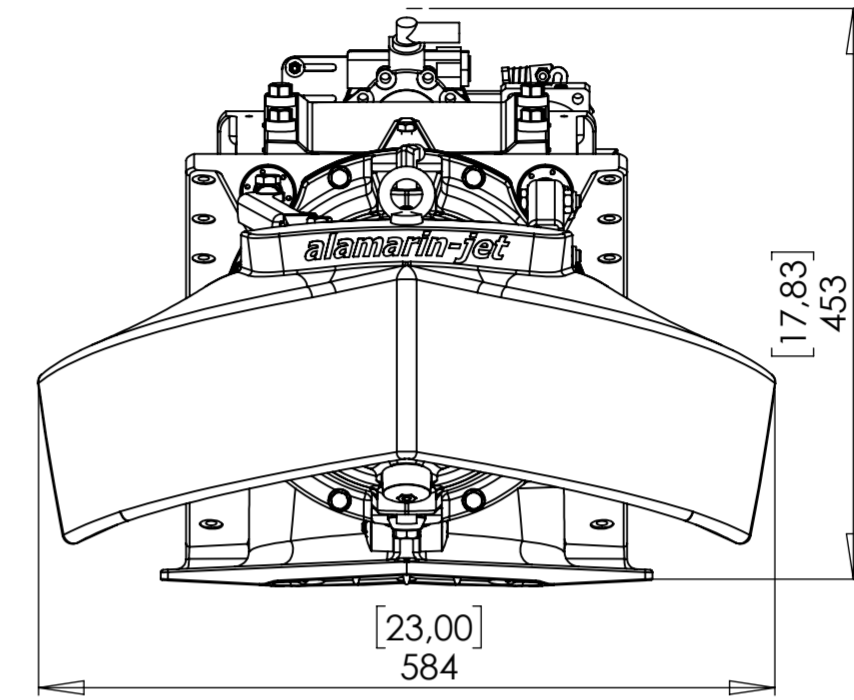
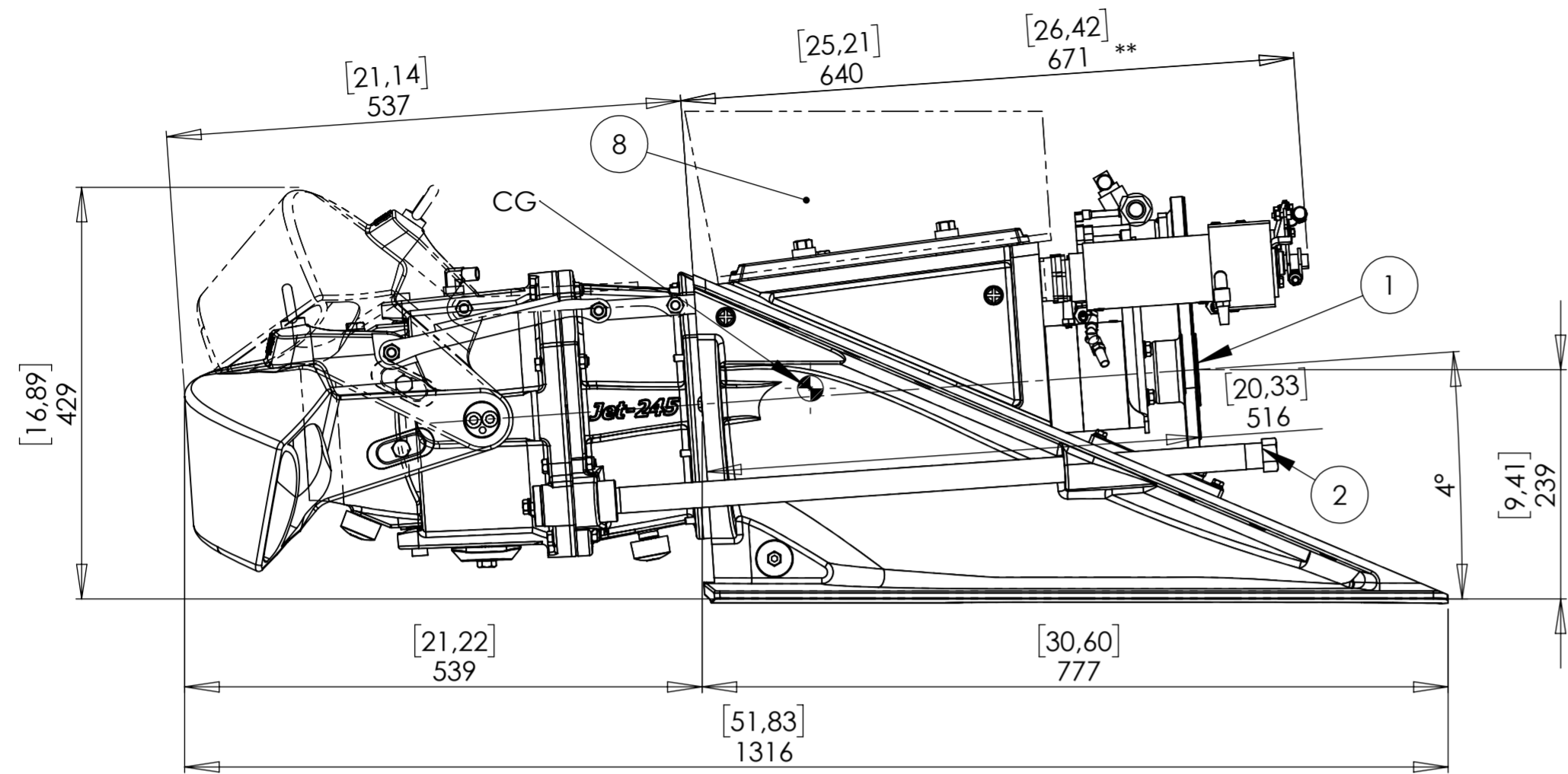

1. DIN-120 drive flange.
2. 3/4" BSP raw water intake.
3. Integrated hydraulic steering cylinder, compatible with common helm pumps.
4. Integrated hydraulic cylinder for reverse deflector control. 33C cable connection.
5. Integrated hydraulic pump unit for reverse deflector cylinder.
6. Integrated oil cooler for reverse deflector cylinder
7. Inspection hatch.
8. Inspections hatch extension (short tail installation). Height depends on waterline level.

Technical data

Max. power	235kW/320hp
Max . rpm	4600 1/s
Vessel displacement	3.5t (single jet, planing)
Impeller diameter	245mm (9.7")
Unit weight	99kg (218lbs)
Entrained water*	23L (6.1gal)

* Volume inside the unit within the boat hull (loss of buoyancy)
 ** With IO control system

Dimensions [inch]
mm

Work Tolerances: Machining SFS4011 (ISO2768) middle Welded structures SFS3393-B length and angles Form and orientation tolerances DIN8570BL3 - E castings SFS-ISO8062	Surface treatment	Surface area [m ²]	Mass [kg]	Designer	10.3.2013	
	Colour		99	HRC		
	Short tail		ISO	Approved	15.6.2013	
			Product code	Version		
			AJ 245	B		
	Size	A2	Scale	1:6	Page	2/3

Muutos / Change	Suunnittelija / Designed	Hyväksyjä / Approved by
Dimension added	Hra 31.10.2018	Hra 31.10.2018

A

A