



## 600B SERIES INSTALLATION GUIDE

*Models 620B, 660B, 680B, Remote and Direct Mount*

*Version 4.1*



### **KONRAD MARINE, INC.**

1421 HANLEY ROAD • HUDSON, WI 54016-9376 USA

Phone: 715-386-4203 • Toll Free: 1-800-927-3545 • Fax: 715-386-4219

[www.konradmarine.com](http://www.konradmarine.com)

All rights reserved. Reproduction or use, without express permission, of editorial or pictorial content, in any manner, is prohibited. No patent liability is assumed with respect to the use of the information contained herein. While every precaution has been taken in the preparation of this book, the publisher assumes no responsibility for errors or omission. Neither is any liability assumed for damages resulting from use of the information contained herein.

All instructions and diagrams have been checked for accuracy and ease of application; however, success and safety in working with tools depend to a great extent upon individual accuracy, skill and caution. For this reason, the publishers are not able to guarantee the result of any procedure contained herein. Nor can they assume responsibility for any damage to property or injury to persons occasioned from the procedures. Persons engaging in the procedure do so entirely at their own risk.

\*Original equipment manufacturer's names, drawings, colors and part numbers are used for identification purposes only.  
We are in no way implying that any of our parts are the original equipment manufacturer's product.



## 600B Series Models

*GENERAL INSTALLATION*

*Version 4.1*

*Part # 13-648*

\*Core Content Originated by Randall J. Sofie, January 2007

\*Adapted for 600 Series - RS, CS, JH, June 2011

\*Adapted for 600B Series - MS, JH, AG Sept. 2015

### **KONRAD, INC.**

1421 HANLEY ROAD • HUDSON, WI 54016-9376 USA

Phone: 715-386-4203 • Toll Free: 1-800-927-3545 • Fax: 715-386-4219

[www.konradmarine.com](http://www.konradmarine.com)



# TABLE OF CONTENTS

Stern Drive General Information .....	6
General Operation .....	6
Safety Notices .....	6
Installation Guidelines .....	7
Figure A: 600B Series Cutout Template .....	8
Figure B: 600B Series X-Dimension Guidelines.....	9
Torque Specifications For Selected Fasteners.....	10
Specified Lubricants.....	11

## KONRAD 600B SERIES DRIVE INSTALLATION

Step 1: Transom Cutout and Installation.....	12
Step 2: Direct Mount/Tailpiece Installation.....	13-14
Step 3: Drive Leg Installation .....	15-17
Step 4: Trim Pump Installation .....	18
Step 5: MerCathode Installation .....	19
Step 6: Oil Reservoir Installation.....	20-21
Step 7: Trim/Lift Control Wiring Installation .....	22-43
Step 8: Trim/Lift Pump Filling/Bleeding Procedure.....	44-45
Step 9: Trim Gauge Installation and Programming .....	46-50
Step 10: Power Steering System Installation.....	51
Steering System Routing Diagrams	
31-031R Single .....	52
31-031R Twin .....	53
31-074R Single .....	54
31-074R Twin .....	55
31-078R Single .....	56
31-079R Single .....	57
31-080R Single .....	58
31-080R Twin .....	59
Step 11: Drive Shaft Alignment Procedures .....	60-64
Step 12: U-Joint Extension Shaft Installation.....	65-66
Step 13: CV Extension Shaft Installation .....	67-68
Step 14: Propeller Installation.....	69-71
(a): 620B Propeller Installation.....	69
(b): 660B Propeller Installation .....	70
(c): 680B Propeller Installation.....	71
Step 15: Installation Review .....	72-73
Inside Vessel Checklist.....	72
Outside Vessel Checklist.....	73
Trim System Component Overview and Trouble Shooting..	74-80
Application Sea Trial Data Forms.....	81-83

# Stern Drive

## General Information

The Konrad 600B Series stern drives are designed to accommodate engines that generate up to 1200 Nm (885 lb. ft.) of torque at maximum rated RPM. Maximum torque ratings are drive model and application dependent.

There is a sixteen degree (16°) trim range to optimize vessel performance while underway. To achieve optimal wear it is recommended that the stern drive be operated between the +2° to -2° degree trim range while under power.

There is an additional 30 degrees (30°) of lift range that may only be used in an emergency or when the stern drive is being serviced or transported.

The Konrad 600B Series stern drives are designed for applications where the vessel transom angle is 13 degrees (13°). Applications that do not meet this criteria may require extra equipment or modifications, or may not be possible at all. The Konrad 620B and 680B stern drives are designed to accommodate propellers (aluminum and stainless steel) with a maximum diameter of 20 in. (50.8 cm). The Konrad 660B can accommodate propellers (aluminum and stainless steel) with a maximum diameter of 16 in. (40.6 cm).

## General Operation

The engine produces power (clockwise or counterclockwise) that is transmitted through a reversing transmission. A coaxial planetary-style reversing transmission is normally used. The transmission is connected to the stern drive via close couple or drive shaft. The power is then transmitted through a series of shafts and gears to the propeller(s).

# Safety Notices

Read and understand all of the safety precautions and warnings before performing any installation or repair.

This list contains the general safety precautions and warnings that **MUST** be followed to provide personal safety. This list is only a suggested safety guideline. Working conditions vary greatly and safety measures will vary upon your individual circumstances.

**ALWAYS USE CAUTION.** Make sure the work area surrounding the product is safe. Be aware of hazardous conditions that can exist.

**ALWAYS** wear protective eyewear and protective footwear when working.

**DO NOT** wear loose-fitting or torn clothing. Remove all jewelry when working.

**DO NOT** work on anything that is supported only by lifting jacks or a hoist.

**ALWAYS** use blocks or proper stands to support the product before performing any service work.

**TO AVOID PERSONAL INJURY,** use a hoist or get assistance when lifting stern drive components. Make sure all lifting devices such as chains, hooks or slings are in good condition and are of the correct lifting capacity.

# Installation Guidelines

- 1) Ensure that the transom is flat within 1/16" (2.0 mm) around mounting area and is properly supported to handle the thrust of the engine and drive combination for the vessel.
- 2) Ensure that the propeller height is established according to the vessel application as determined by the Konrad Application Engineer. The height of the propeller is critical to a successful application. If the propeller centerline is too low, excessive drag can occur based on transom assembly location. Intermediate spacers are available if needed.
- 3) Ensure water flow to the propeller is clear and consistent without interruptions. Protrusions on the hull surface create a negative pressure area and induce turbulence. Turbulence can

cause severe propeller inefficiency and excessive torsional vibration. There are to be no such protrusions within 2.5 meters forward of the propeller(s).

Common causes of interruptions are:

- Water pickup
  - Sonar transducers
  - Retrofitted surfaces which are not properly faired or smoothed
  - Any hull shape which does not provide smooth transition
  - In heavy applications, the bow can produce turbulence if the attitude of the vessel is weighted forward
  - Improper listing of the vessel due to weight distribution
- 4) Ensure that the vessel center of gravity is properly placed. Excessive weight forward or aft can significantly affect performance and the efficiency of the propeller.
  - 5) Ensure that the stern drive is trimmed to the correct level. While under-trimming can cause premature u-joint wear, over-trimming can cause propeller inefficiency, porpoising, and premature gear wear.

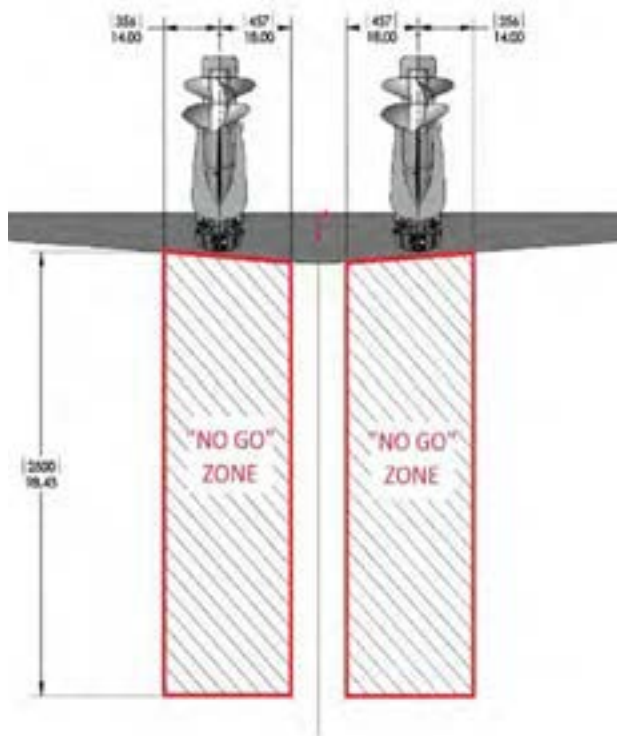

# Figure A: 600B Series Cutout Template



The installer is responsible to ensure that the transom is properly supported for the thrust of the system

KONRAD 600B SERIES CUTOUT

13-548 (SHEET 1 OF 2)

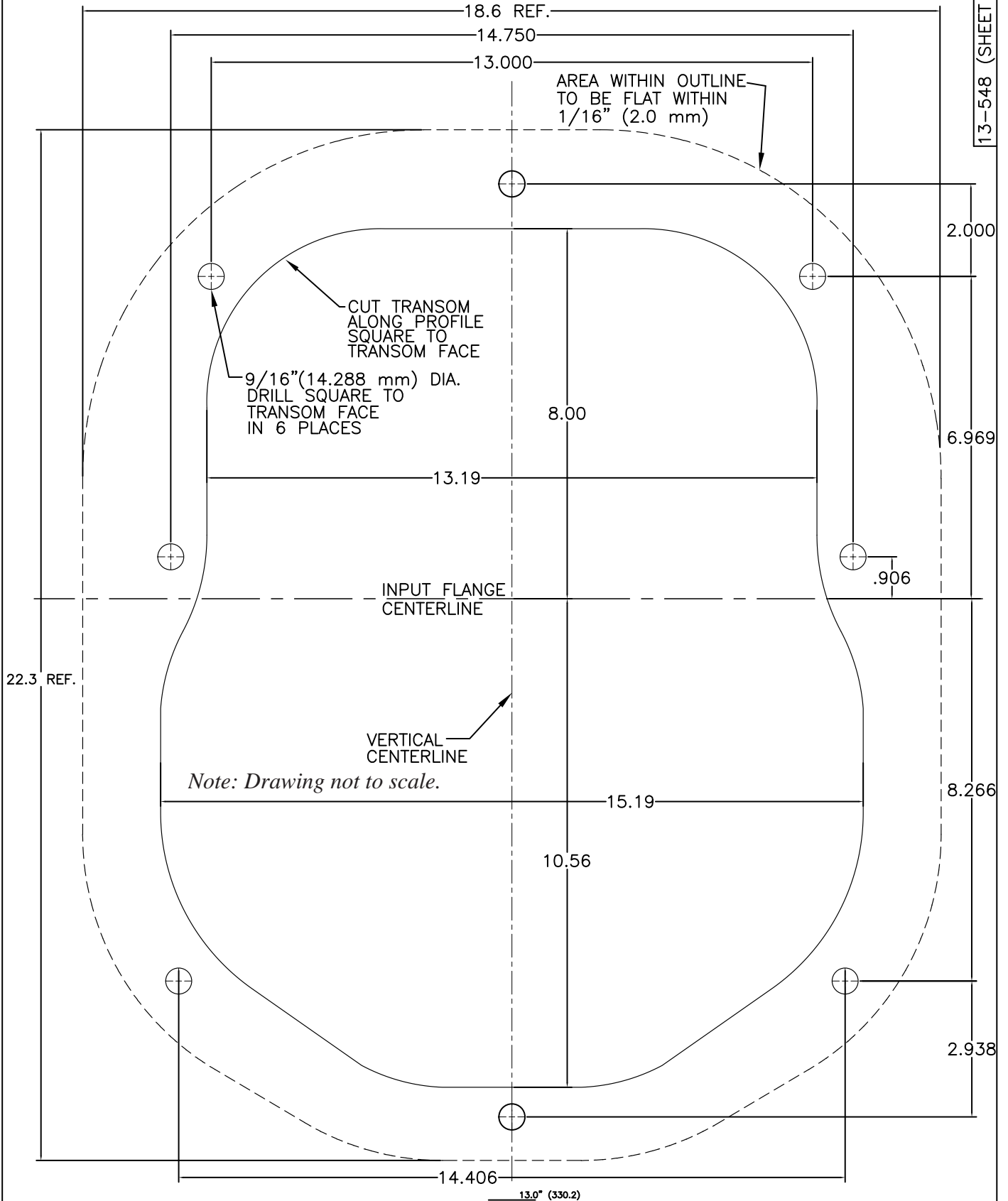



# Figure B: 600B Series X-Dimension Guidelines

**Konrad**

600B SERIES

SALES: (800) 927-3545

13-548 (SHEET 2 OF 2)

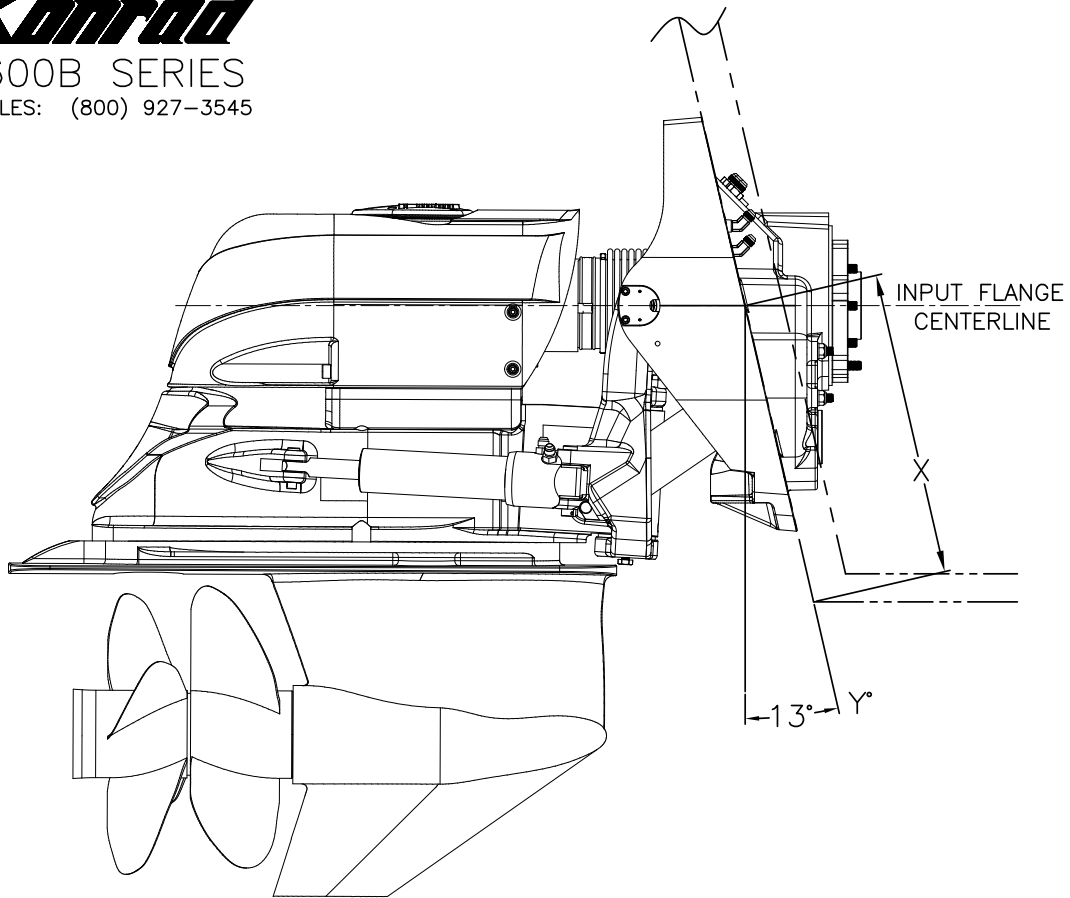

## 620/660/680 "X" DIMENSION

1. Typical transom distance is 17.5" (444.5 mm) @ 13°  
(Please consult sale representative for final recommendation)
2. Measure the transom angle Y° as displayed in the above drawing.
3. Fold the bottom of cutout template provided along the line listing the correct distance.
4. Cut the sheet using the fold as a guide.
5. Tape cutout template to the aft side of the transom with the bottom cut edge of the cutout template aligned to the bottom of the transom.

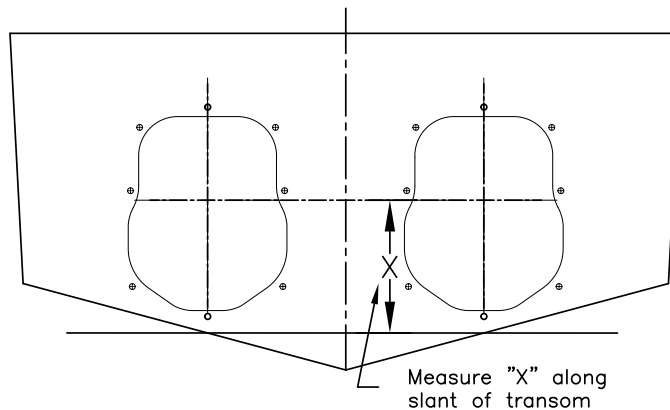

**IMPORTANT:** Damage to Konrad products caused by too high or too low of a Konrad recommended install height will not be covered by Konrad warranty.

## Torque Specifications for Selected Fasteners

Description	Torque Value
Transom Assembly / Gimbal Housing Studs to Inner Transom Plate Nuts (6)	50 lb. ft. (67.8 Nm)
Gimbal Ring Center Pivot Pin Cover Hex Head Cap Screws	35 lb. ft. (47.5 Nm)
Gimbal Ring Center Pivot Pin Retaining Hex Head Cap Screw	50 lb. ft. (67.8 Nm)
Trim Sender Cover Button Head Cap Screws	13 lb. in. (147 N cm)
Trim Sender Housing Cap Screws	8 lb. ft. (10.8 Nm)
Trim Sender Socket Head Cap Screws	8 lb. ft. (10.8 Nm)
Lifting Bracket Top Cover Button Head Cap Screws (5)	20 lb. ft. (27 Nm)
Gimbal Carrier Compression Ring Socket Head Cap Screws Tail piece Compression Ring Hex Head Cap Screws	45 lb. ft. (61 Nm) 35 lb. ft. (47.5 Nm)
620 Propeller Nut (1)	80 lb. ft. (109 Nm)
660 Forward Propeller Nut (1)	100 lb. ft. (136 Nm)
660 Aft Propeller Nut (1)	60 lb. ft. (81 Nm)
680 Forward Propeller Nut (1)	100 lb. ft. (136 Nm)
680 Aft Propeller Nut (1)	80 lb. ft. (109 Nm)

# Specified Lubricants

## Gear / Drive Oil

<b>Konrad 75W90 Full Synthetic Oil</b>		<b>Part number</b>
1 Quart	(.95 Liters)	(13-090)
2.5 Gallon	(9.5 Liters)	(13-091)
55 Gallon	(208 Liters)	(13-092)



### Lubricant Capacity 600B Series (standard configuration) \*\*

Complete Sterndrive, 620B model - **approximately** eighteen (18) quarts (17 Liters).  
Complete Sterndrive, 660B model - **approximately** sixteen (16.5) quarts (15.1 Liters).  
Complete Sterndrive, 680B model - **approximately** eighteen (18) quarts (17 Liters).

**\*\* Oil capacities will vary depending on application configurations, such as spacers, by 1-3 quarts (.95-2.84 liters)**

**Make sure the drive is completely filled to the top and line from reservoir is purged of air prior to operating.**

## KVD Transmisson

<b>Mobiltrans HD30 Drive-train Oil SAE 30</b>		<b>Part number</b>
1 Gallon	(3.79 Liters)	(13-758)

**Approved Alternative - Shell Spirax S4 CX 30**

### Fluid capacity

Fluid capacity will vary depending on the location, transmission model, and length of cooler hoses. Refer to the Velvet Drive owners manual for instructions on how to check the fluid level.

## Trim / Lift pump

<b>Dexron III automatic transmission fluid</b>		<b>Part number</b>
1 Quart	(.95 Liters)	(10-585)

### Fluid capacity

Trim Pump Reservoir - approximately (1) quart (.95 Liters)

## Steering system

<b>Dexron III automatic transmission fluid</b>		<b>Part number</b>
1 Quart	(.95 Liters)	(10-585)

### Fluid capacity

Capacity will vary depending on the type of steering system used and hose length.

# Step 1: Transom Installation

1.1 Locate the Cutout Template (13-548) that is packaged along with the manuals in the drive shipment. Place the cut out on the transom of the vessel following the mounting height guidelines established for the vessel's application.



1.2 Carefully drill and cut out the transom of the vessel according to the template.



Clean the area and prep for installing the transom assembly.

1.3 Apply marine grease to the gasket around the transom assembly. Carefully lift the transom assembly into place, guide the eight (8) studs through the drilled holes and secure by sliding the inner transom straps (13-675), round flat washers (10-584) and nylock nuts (13-623) over the studs on the sides. Place the two (2) square backing plates (10-941) onto the top and bottom center studs, secure using the remaining nylock nuts (13-623).

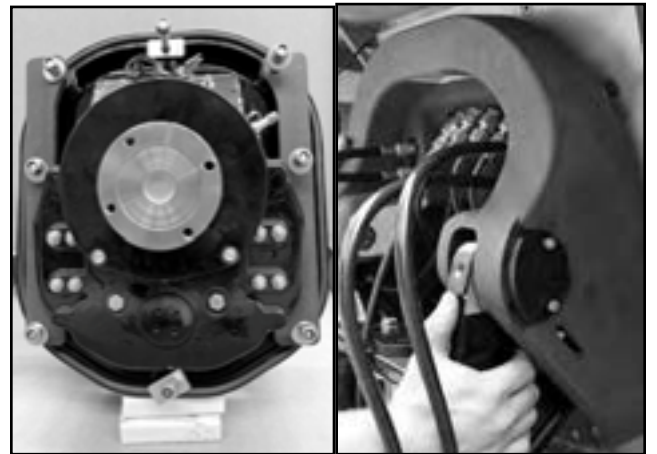

1.4 Attach one end of the continuity cable (31-094) to one of the transom studs, and secure. The other end will be connected to the engine ground.

1.5 Tighten the nuts evenly in a star pattern until the final torque of 50 lb. ft. (67.8 Nm) is reached.

1.6 Remove the two (2) H.H.C.S. and washers from both the bottom and top plates on the gimbal ring, then remove the plates.



**NOTE:** Be careful to keep the top center pin bushing in place for installing the drive later.

**NOTE:** If the application uses a drive shaft, proceed to Step 3: Drive Leg Installation.

## Step 2: Direct Mount / Tailpiece installation

### Direct Mount / Tailpiece Assembly - 30-998

2.1 Remove the tailpiece compression ring and oring from the transmission tailpiece by removing the five (5) H.H.C.S. and washers.

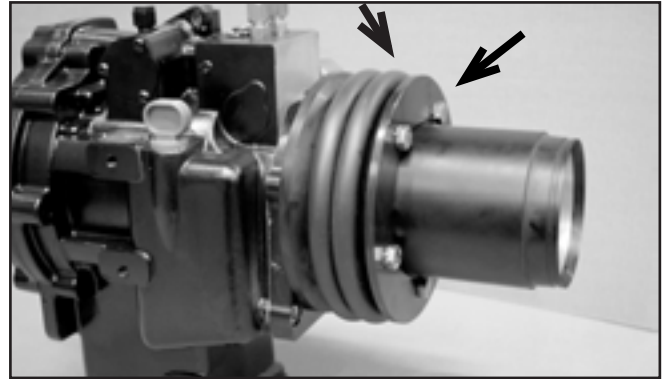

2.2 Position the tailpiece compression ring and oring onto the gimbal housing by sliding the ring and gasket from the bottom of the gimbal housing upward under the trim hoses and into position.



2.3 With the transmission and tailpiece mounted on the engine, position the tailpiece to slide through the gimbal housing. Hold the tailpiece compression ring and oring so it will slide onto the tailpiece housing while positioning the engine and transmission into place.



2.4 Apply red *Loctite* to the (5) H.H.C.S. that were removed in Step 2.1. Start the bolts by hand and tighten in a star pattern at 5 lb ft (6.8 Nm) increments until 35 lb ft (47.5 Nm) is obtained.



## Step 2: Direct Mount / Tailpiece installation (continued)

2.5 Tool TO-189 is used to align the engine, transmission and tailpiece with the gimbal housing.

**NOTE: These steps must be completed prior to installing the stern drive.**

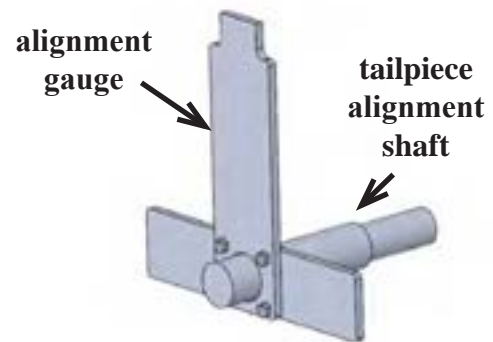

2.6 Slide the tailpiece alignment shaft (TO-189-A) all the way into the tailpiece output.



2.7 Hold the top portion of the alignment gauge against the flat surface on the top of the gimbal housing. Slide the gauge towards the back of the tailpiece until it is flush with the tailpiece.

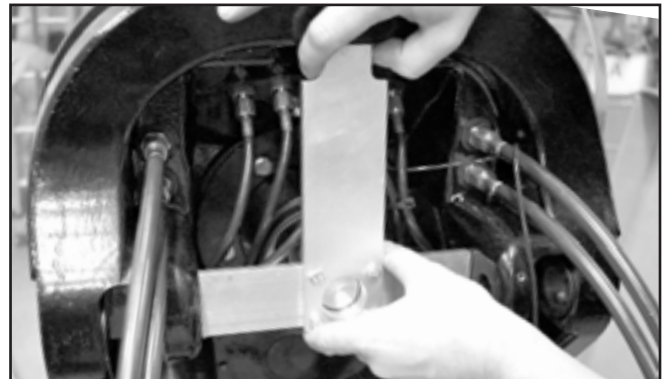

Adjust the engine mounts until the gauge slides over the alignment shaft while sitting flush against the tailpiece housing, and the top of the gauge is up against the flat on the upper portion of the gimbal housing.

2.8 When the correct alignment is made, the alignment pin will be centered in the alignment gauge as shown in the picture to the right.

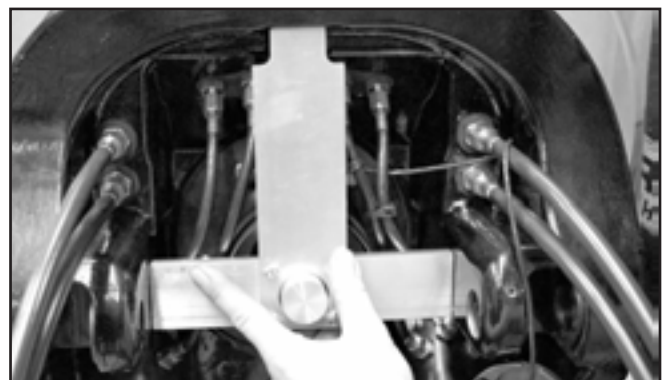



## Step 3: Drive Leg Installation

3.1 Install the u-joint bellows (10-230) on the output flange of the gimbal bearing carrier assembly. Position the bellows with the “TOP” mark facing upward.

Install the grounding clip on the bellows making contact with the gimbal bearing. Tighten the forward clamp.



3.2 Prepare the Konrad drive leg for installation by securing it upright. (A lifting ring is included with the drive and is located in the packet with the manuals). You may install the lifting ring by removing the plug on top of the drive's top cap and threading it into place.

***NOTE: Stern drive is shipped full of oil, secure drive upright before removing plug and installing lift ring.***



3.3 Locate the alignment pin shipped with the manual packet. **Apply marine grease to the pin, end yoke splines, and o-ring.** Install one end of the pin into the end of the yoke assembly. Use the other end of the pin to help guide the end yoke into the splines of the gimbal housing.

3.4 Remove the center pivot pin and retaining bolt from the intermediate section of the drive, to be reinstalled later.

3.5 Slide the drive toward the transom assembly, aligning the center of the gimbal ring with the drive's intermediate pivot point. Carefully sliding the u-joint end yoke into the bellows and at the same time rotate the u-joint to help align with the gimbal housing splines.

**WARNING! Do not impact or apply force to the drive while engaging the input shaft as this will damage the gimbal carrier seal.**

Install the grounding clip on the bellows so it makes contact with the bearing carrier. Tighten the aft clamp.



## Step 3: Drive Leg Installation (continued)

3.6 Apply marine grease onto center pin and install the center pivot pin (13-832 for contactless sensor or 13-561 for contact sensor) into the lower gimbal ring and into the intermediate section the drive.

*Note:* Use the slot on the bottom of the pin to align the hole for the retaining bolt at the bottom of the intermediate housing.

3.7 Put red *Loctite* on the H.H.C.S. (13-560) and install into the intermediate section (as shown in picture to the right). Tighten into the center pivot pin at 50 lb.ft. (67.8 Nm).

3.8 Reinstall the bottom cover (13-320), lock washers (13-670), and the H.H.C.S. (13-310). Apply blue *Loctite* and tighten the H.H.C.S. to 35 lb.ft (47.5 Nm).

3.9 Remove the screw from the top starboard side of the intermediate and attach the continuity cable from the transom assembly.

3.10 Install the sensor magnet (13-842) to top of center pin (13-832) with notch facing forward. Apply blue *Loctite* and tighten two S.H.C.S. (13-840). For contactless sensor, reinstall the top cover plate with sensor facing forward, aligning wire with notch on magnet.

*(For contact sensor 31-053)* Reinstall the top cover plate with rudder indicator sensor (if equipped) facing forward aligning the sensor and wiring with the slot on the top portion of the pivot pin. There is a small indicator on the shaft of the sensor indicating the side to align with the wiring and the slot of the shaft. *(See arrow in picture)*

3.11 Apply blue *Loctite* to the H.H.C.S (12-378) and reinstall into the washers (13-670), and top plate, then tighten into the gimbal ring.

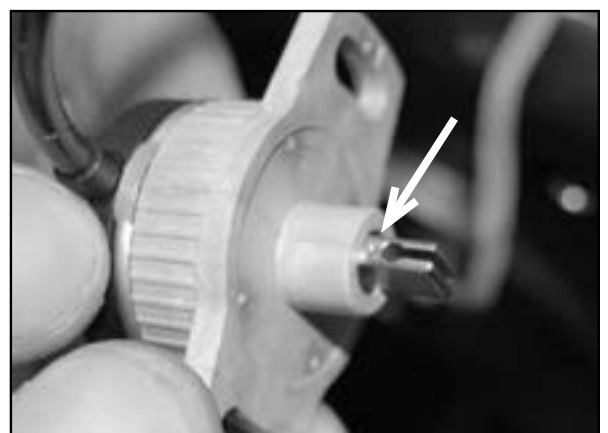
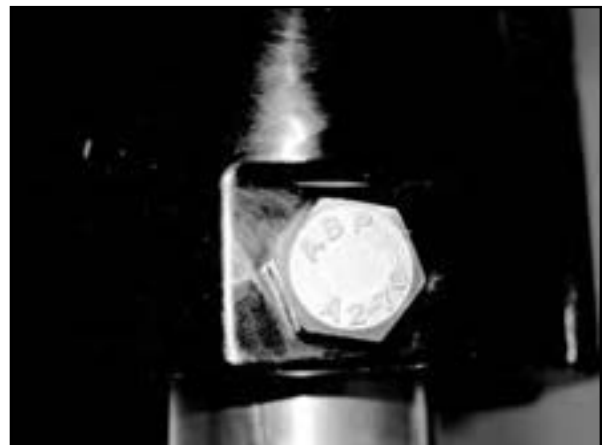



## Step 3: Drive Leg Installation (continued)

3.12 Install the steering rams onto the drive by placing the two (2) bushings (13-319) on the steering ram eyelet. Place the steering ram between the steering tabs on the drive. Clevis pin (13-341), slides through the top steering tab and downward through the steering rod and out the bottom tab. Install flat washer (12-352), and secure with cotter pin (13-368) by sliding through the hole at the bottom of clevis pin and bending the legs of the cotter pin back around the outside of the clevis pin.

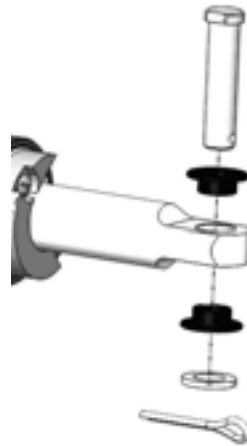

Repeat this process for both port and starboard sides.

3.13 Remove lifting ring from drive and reinstall gasket (10-285) and plug (10-010) into top cap (13-421).

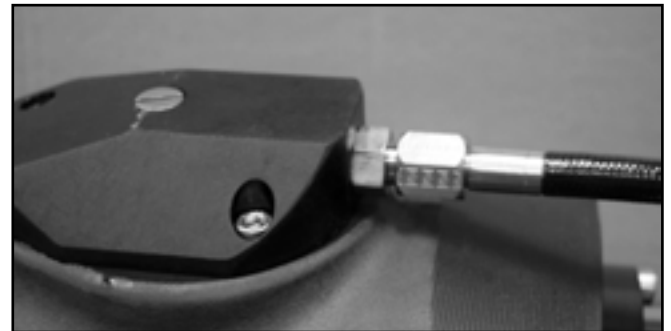

3.14 Remove cap (13-012) from fitting (11-702). Place blue *Loctite* on oil vent hose fitting (11-702), and install oil supply hose (31-130) from the gimbal housing and tighten.

3.15 Install the cover onto the upper housing. Place blue *Loctite* onto the S.H.C.S. before placing them through the flat washers and hand tighten.

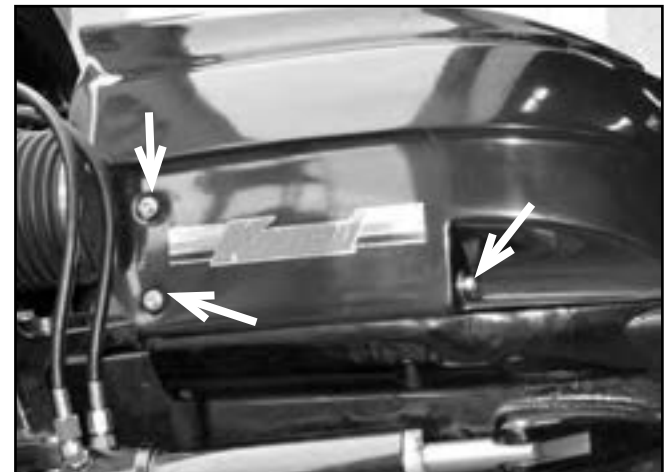

Install two (2) M6 X 18mm S.H.C.S (13-696) into the forward upper side of the cover. Install two (2) M6 X 18mm S.H.C.S (13-696) into each forward bottom side hole in the cover.

3.16 Install two (2) M6 X 18mm S.H.C.S. (13-696) with blue *Loctite* and washers (12-335) on the aft side of the cover and tighten.

3.17 Install splash deflector (13-403), using the four (4) H.H.C.S. and washers supplied with the deflector plate into the lower gimbal housing. Apply red *Loctite* to the bolts and tighten to 35 lb.ft. (47.5 Nm)

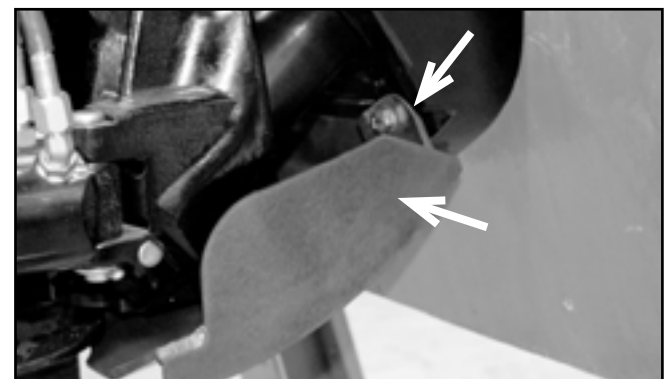

*See photo to right.*

## Step 4: Trim Pump Installation

4.1 Apply blue *Loctite* to each of the transom trim fittings (13-575), then attach one end of each of the four (4) trim hoses (13-702) to the four (4) transom fittings (13-575).

**NOTE:** Six (6) total trim hoses are included with each drive. (4) 13-702 for transom to manifold and (2) 13-703 for trim pump to manifold.

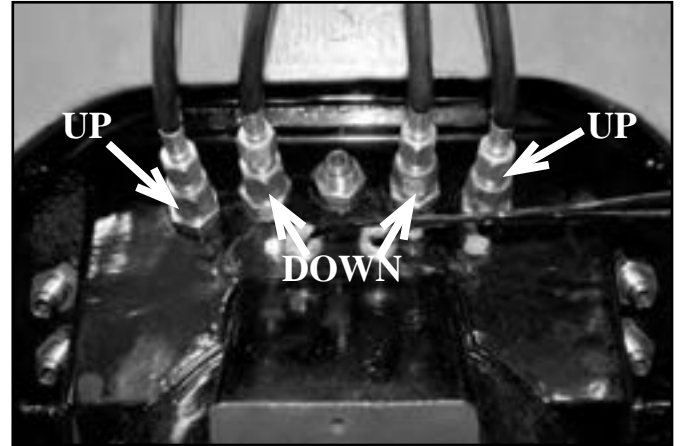

4.2 Mount the trim system manifold in the desired location, and attach the opposite ends of the trim hoses (13-702) to the four (4) fittings.

**NOTE:** Trim hose lengths are 24 inches (60cm) each)

4.3 Install one end of the remaining two (2) trim hoses (13-703) to the bottom fittings on the trim manifold. As seen in image to the right.

**NOTE:** Apply blue *Loctite* to all the hose fittings on final install.

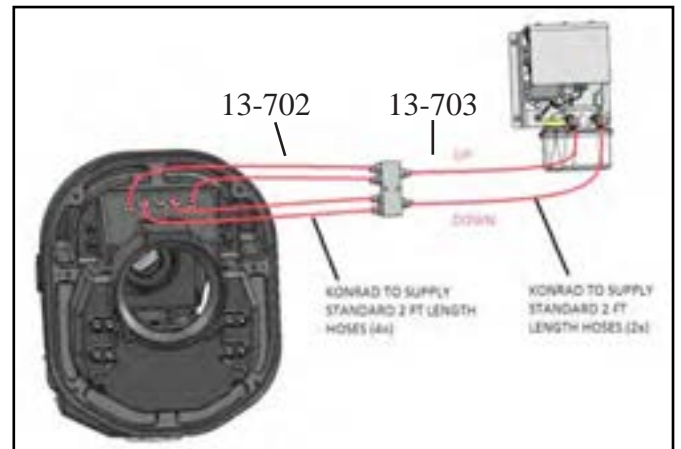

4.4 Mount the trim pump in the desired location within 24 inches (60cm) of the trim system manifold, and install the remaining hose ends onto the pump fittings.

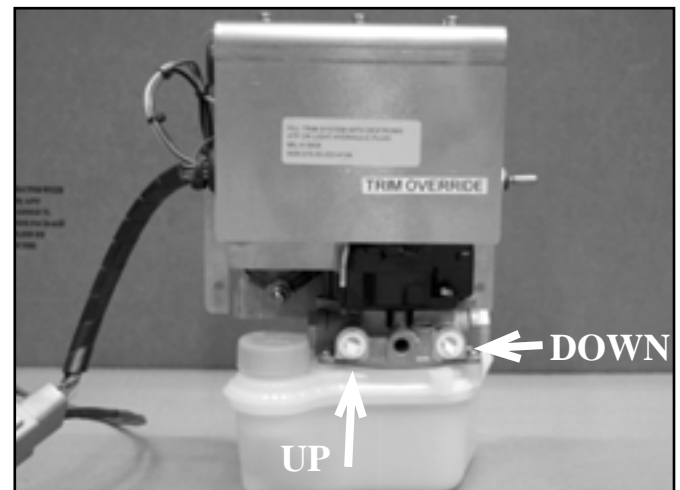

## Step 5: MerCathode Installation

The transom can be equipped with a Mercury MerCathode kit. The reference electrode and anode assembly can be mounted on the transom/gimbal housing assembly by removing the plugs mounted on the lower portion.

5.1 Mount the MerCathode controller to the inside of the transom or other vertical surface and is within reach of the wire leads.

### CAUTION!

Disconnecting or connecting the battery cables in the incorrect order can cause injury from electrical shock or can damage the electrical system. Always disconnect the negative(-) battery cable first and connect it last.

**NOTE: Prevent galvanic corrosion resulting from inadequate electrical power to the MerCathode system. Avoid using switches in the system and ensure current is always available from the battery.**

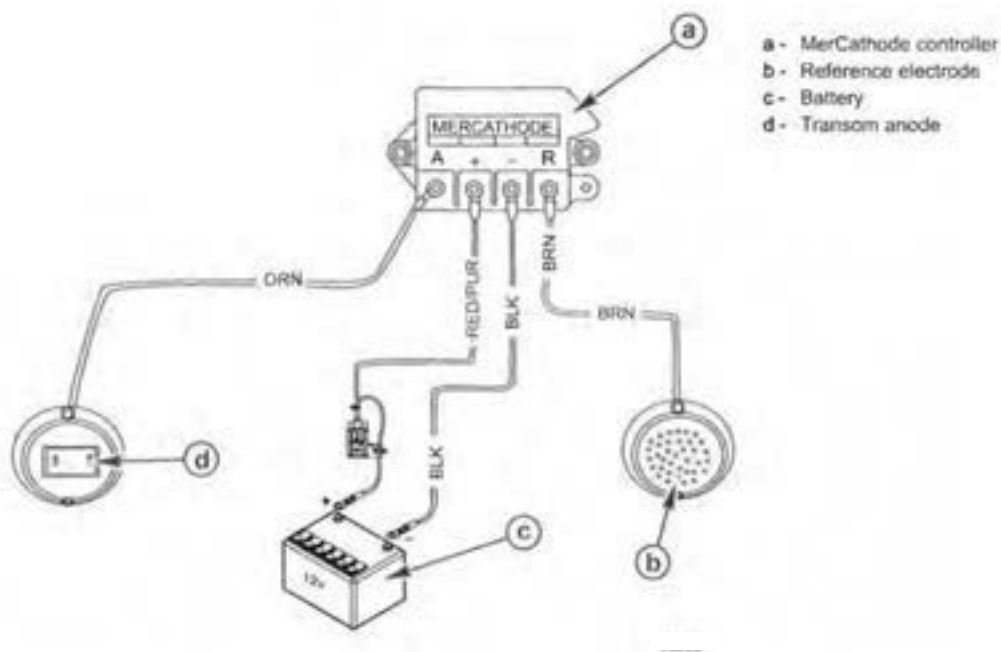

5.2 Connect the red /purple wire assembly (with fuse) between the controller and battery positive (+) terminal. Check the fuse for proper installation.

5.3 Connect the black wire assembly to the controller and the battery negative (-) terminals.

5.4 Connect the anode lead (orange) to the controller terminal marked “A”.

5.5 Connect the electrode lead (brown) to the controller terminal marked “R”.

5.6 Secure all connections and apply a thin coat of liquid neoprene sealant (Mercury Marine part # 92-25711 3) to all exposed terminals and fasteners

## Step 6: Oil Reservoir Installation

6.1 The oil reservoir assembly (30-992) that is shipped with each drive consists of a 4 qt (3.79 L) bottle with molded mounting brackets, low oil level sensor and a vented cap.



6.2 Locate and mark the desired mounting location for the oil reservoir on the transom keeping within 12-18 inches (30-45.7 cm) of the trim pump assembly. This is a gravity fed system and must be mounted above the oil input line to the drive.

Make sure there is enough clearance to fill the bottle with oil, and it is clear of any steering or other moving parts that maybe installed later.

6.3 Mount the bottle with a minimum of four (4) of the appropriate fasteners, (using more fasteners for rough water applications).



6.4 Connect the oil supply line hose to the bottom of the reservoir.

Direct Mount application: go to Step 5.7 for installation of fitting side of hose.

Remote Mount application only: route other end of the hose to one side of the brass "T" fitting and secure both ends with a hose clamp.



## Step 6: Oil Reservoir Installation (continued)

6.5 Place one end of the hose onto the brass “T” fitting. (Remote Mount only)

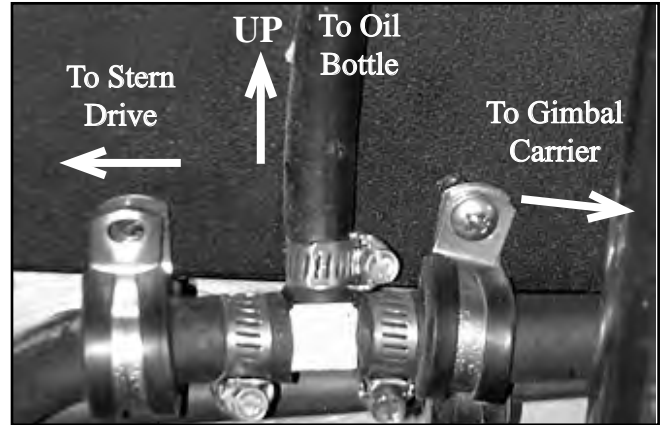

6.6 Connect the opposite end of the oil supply hose to the barbed fitting on the gimbal carrier and secure with a hose clamp. (Remote Mount only)

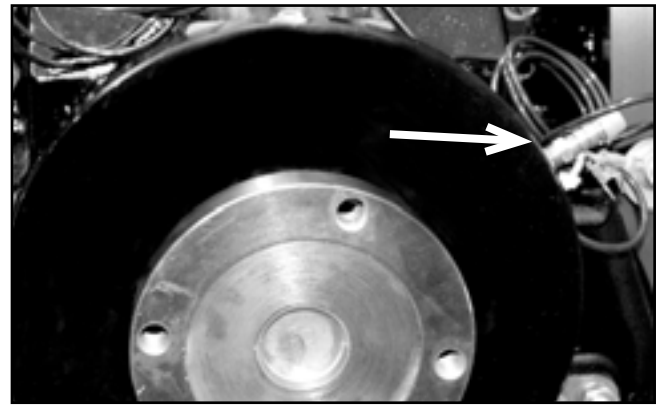

6.7 Apply blue *Loctite* to the center fitting on the transom assembly. Install oil supply hose with the adapter fitting onto transom fitting and tighten. Route other end of hose to the final location on the “T” fitting.

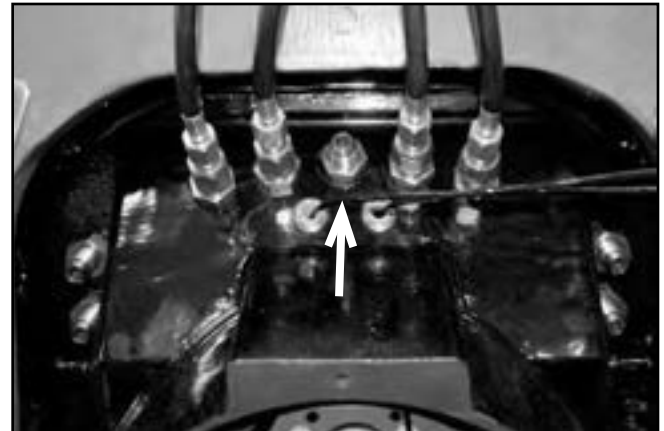

**NOTE:** *Oil hose should be cut to length for easiest downward flow to both the drive and the gimbal carrier.*

6.8 Fill oil reservoir to “Fill” line using Konrad High Performance Gear Lubricant. Available in a 1qt (.946 L) bottle (13-090) or 2.5 gallon (9.46 L) bottle (13-091).





# Step 7: Trim Control Wiring Installation

**NOTE:** *Wire style and gauge shall meet requirements of the ABYC, local, state and national codes.*

Trim pump circuit requires in-line fuse/breaker (on the positive lead) of the following values:

- 1) 12 Volt = 100 Amperes
- 2) 24 Volt = 50 Amperes

This item should be mounted in an accessible and logical position away from bilge fluid contact. It must also be labeled clearly.

Wiring from the batteries to the trim pump must meet the specifications listed in the chart below.

Length	12 Volt	24 Volt
0-30 Feet	4 AWG	6 AWG
0-9.1 Meters	25 mm <sup>2</sup>	16 mm <sup>2</sup>



**NOTE:** *Battery, or batteries, must be disconnected while all electrical connections are being made or serviced.*

**NOTE:** *Refer to the Trim System Electrical Drawings for further instructions.*

## Step 7: Trim Control Wiring Installation (continued)

7.1 Remove the front cover of the trim pump assembly by removing the three (3) H.H.C.S. and lock washers from the top of the assembly.

7.2 Remove the remaining three (3) H.H.C.S. and lock washers. Remove the top portion of the trim pump assembly bracket.

7.3 Attach the positive trim pump power feed (from the fuse or breaker unit) to one of the solenoid bolts on the link-bar side.

**NOTE: coat terminal with corrosion protectant.**

7.4 Attach the negative power feed to the trim pump ground bolt.

**NOTE: coat terminal with corrosion protectant.**

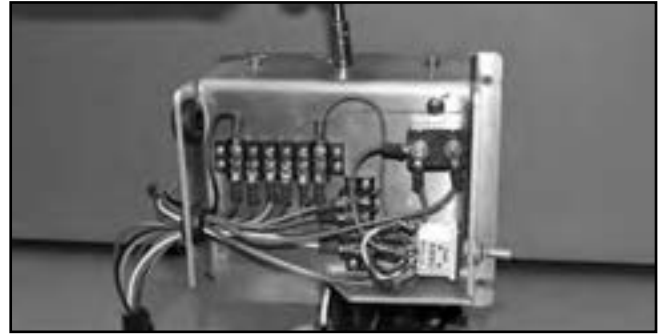

## Step 7: Trim Control Wiring Installation (continued)

7.5 Reinstall the top portion of the trim pump assembly bracket that was previously removed.

7.6 Unwrap the twist ties from the wires for the trim and rudder indicator (if equipped) sensor(s). Route the wires across the transom securing every 6 inches. Keep track of which wire harness goes to which sensor.

*The port side harness is for the rudder indicator  
The starboard side harness is for the trim.*

7.7 Feed the wires through grommet in the top opening of the trim pump assembly bracket and connect them to the appropriate terminals of the 6 position horizontal terminal strip.

**NOTE:** *The brown wires for the contactless sensor or the black wires for the contact sensor are routed to terminal 2.*

*The white wires for contactless sensor and yellow wires for the contact sensor are for the rudder and will be routed to terminal 3.*

*The white wires for contactless sensor and the yellow wires for the contact sensor are for the trim and will be routed to terminal 4.*

*The green wires for contactless sensor and red wires for contact sensor are routed to terminal 5.*

**NOTE:** *Numbering for the terminals starts on the left side with number 1 and goes to the right.*

**NOTE:** *Coat the terminals with corrosion protectant.*

7.8 Route the low oil level sensor wires from the oil reservoir to the trim pump and attach to the positions 1&2 on the 4 position vertical terminal.

**NOTE:** *Numbering for the terminals starts on the top side with number 1 and goes downward.*

**NOTE:** *Coat the terminals with corrosion protectant.*

7.9 Reattach the trim pump assembly cover.

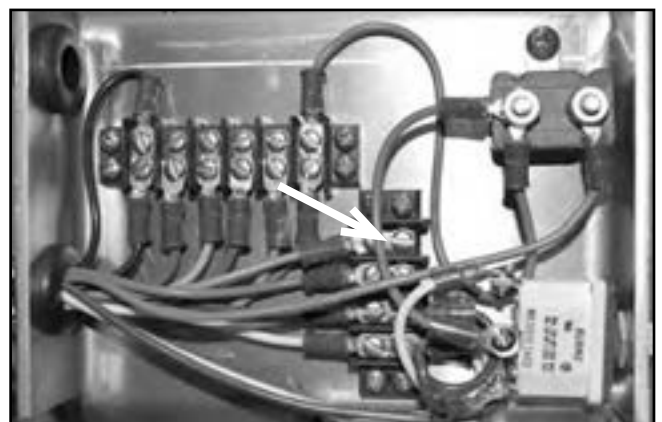
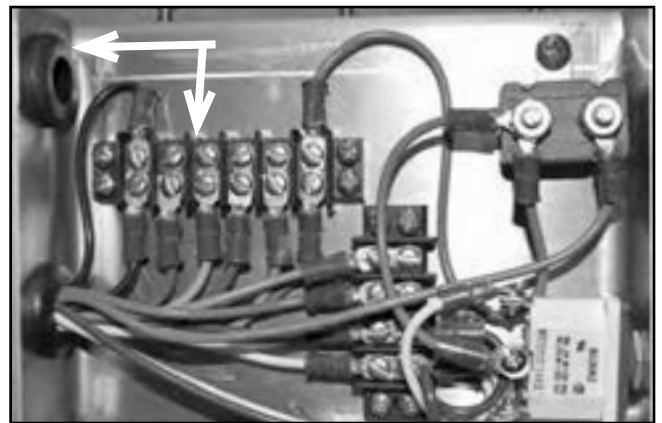
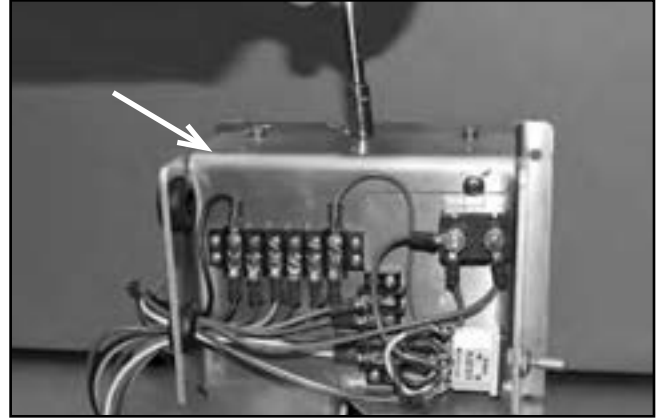



## Step 7: Trim Control Wiring Installation (continued)

7.10 Attach the trim control module(s) (13-543, 13-697, or 13-698) to the transom within 24 inches (60cm) of the trim pump.

**NOTE: Each module is programmed for either port, center, or starboard. Make sure to mount in the appropriate position. Single (13-543)  
Twin (Port 13-543, Starboard 13-697)  
Triple (Port 13-543, Center 13-697, Starboard 13-698)**

- Part numbers are scribed on top of Module
- Part number coincides with orientation

7.11 Connect the appropriate wire harness connector to the trim control module.



7.12 Connect the large wire harness connector from trim control module to the large connector at the trim pump.

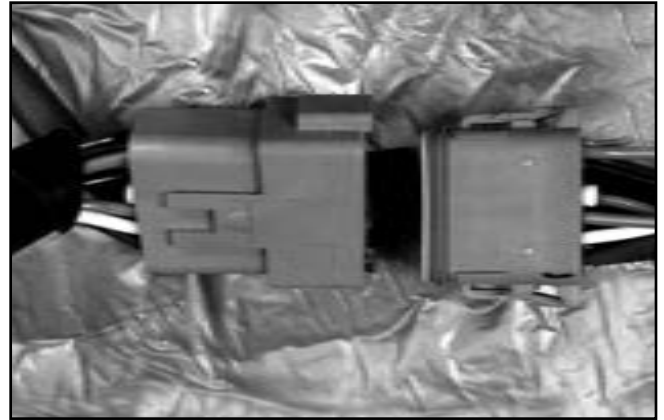

7.13 Connect the small three pin connector at the trim pump with the one from the wire harness.

7.14 Route wire harness to helm area to the mounting location of the trim gauge. Wire the trim control harness pigtail to the power source and other designations as called out on the corresponding electrical drawing.

**NOTE: Battery or batteries must be disconnected while all electrical connections are being made.**

**NOTE: (See Trim System Electrical Drawing for your specific vessel configuration).**



# Step 7: Trim Control Wiring Installation (continued)

# KONRAD

## SINGLE WIRING

### Single Drive, Single Helm

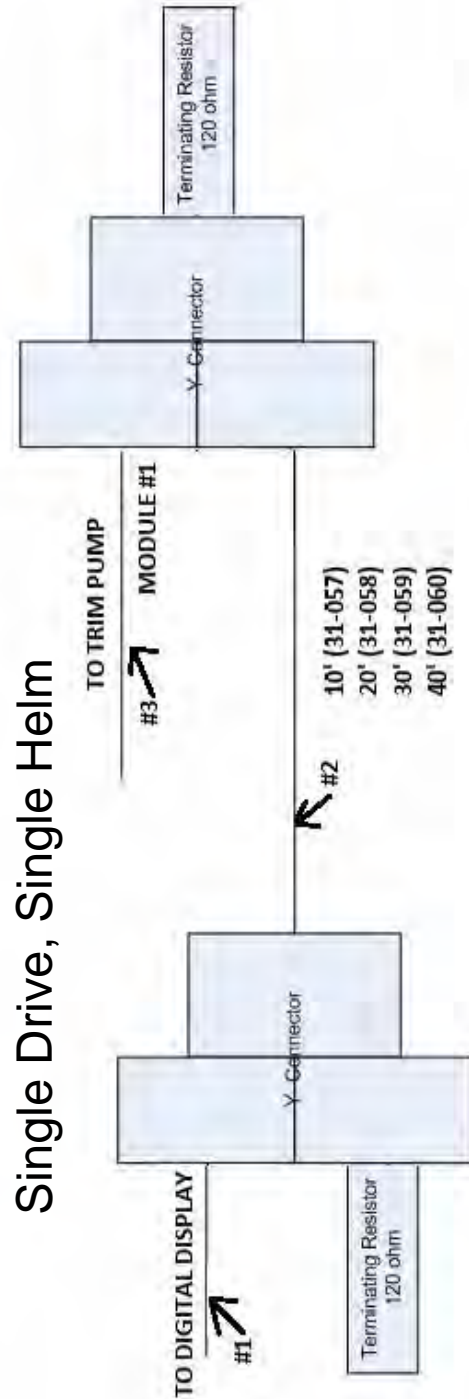

SHIPPING TAG #'S

- #1
- #2
- #3

Note:  
 All Y-CONNECTORS HAVE 3 PORTS (2 TRIANGLE WEDGES PORTS, 1 CIRCLE WEDGE PORT). ALL ACCESSORIES (DISPLAY, TRIM PUMP) CAN-BUS LINES HAVE CIRCLE WEDGES (ORANGE) THAT PLUG INTO CORRESPONDING PORT ON THE Y-CONNECTOR. ALL JUMPER HARNESSES HAVE TRIANGLE WEDGES (BLUE) THAT PLUG INTO CORRESPONDING PORT ON THE Y-CONNECTORS.

# Step 7: Trim Control Wiring Installation (continued)

KONRAD MARINE INC.  
TRIM SYSTEM ELECTRICAL  
DRAWING (12 VOLT) 600B  
SINGLE DRIVE

AS OF 01 APRIL 2021  
REVISED FROM  
K.M. P/N 31-193

ORIGINAL SENSOR K.M. P/N 31-053  
WAS RD (NOW GR)-POWER (+)  
WAS BL (NOW BR)-GROUND (-)

LOCATED ON  
SIGNAL ASSEMBLY

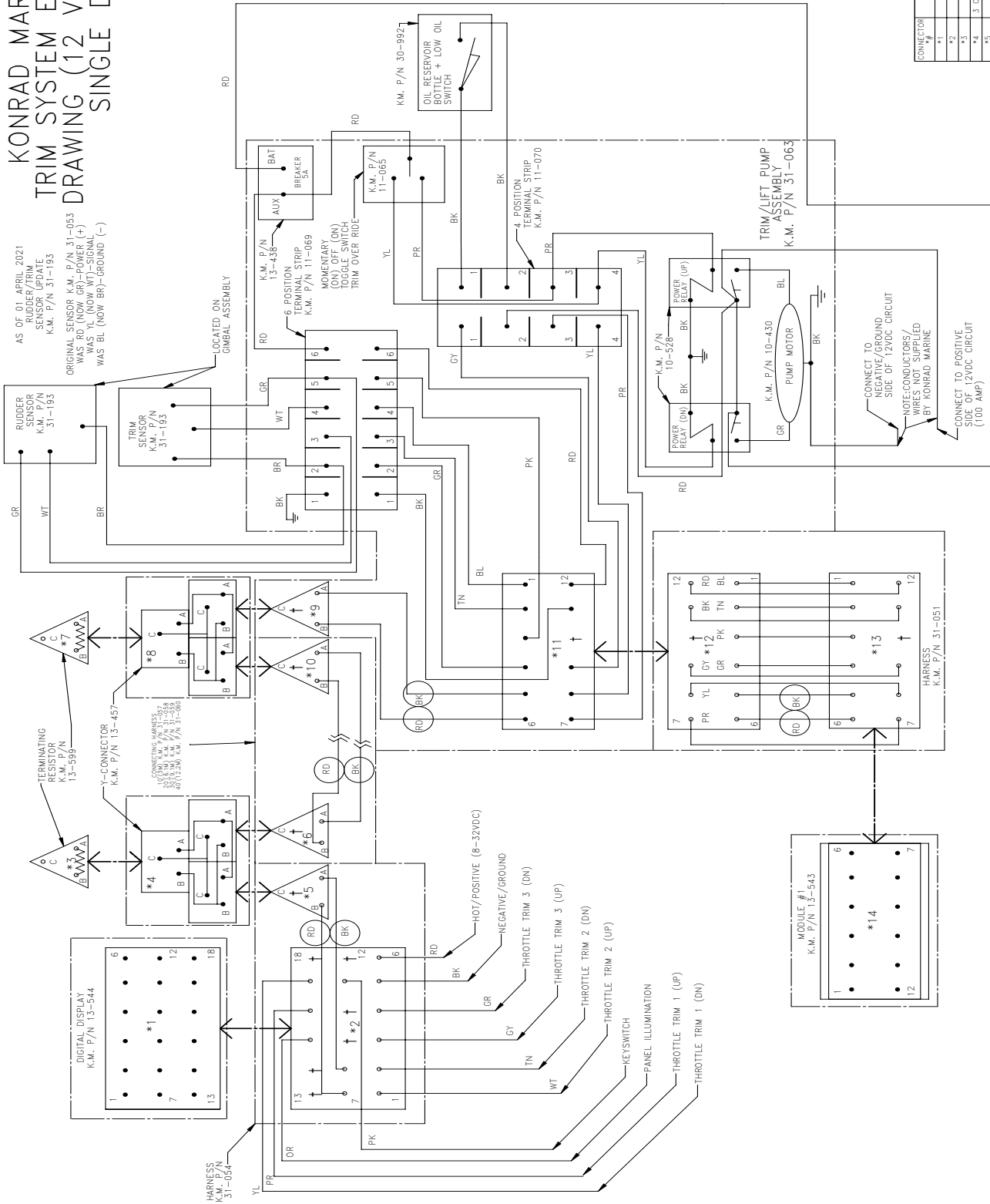

CONNECTOR	DESCRIPTION	MATING CONNECTOR
*1	18 CAVITY FEMALE	*1
*2	18 CAVITY FEMALE	*2
*3	3 CAVITY MALE	*3
*4	3 CAVITY 3 WAY FEMALE Y	*4
*5	3 CAVITY MALE	*5
*6	3 CAVITY MALE	*6
*7	3 CAVITY MALE	*7
*8	3 CAVITY 3 WAY FEMALE Y	*8
*9	3 CAVITY MALE	*9
*10	3 CAVITY MALE	*10
*11	12 CAVITY FEMALE	*11
*12	12 CAVITY MALE	*12
*13	12 CAVITY MALE	*13
*14	12 CAVITY FEMALE	*14

DRAWING BY A.G.  
AUGUST 2015  
REVISION 1 MAY 2016  
REVISION 2 APRIL 2021 (S.C.)

NOTES FOR HARNESS K.M. P/N 31-054:  
1) ALL WIRES ARE PIGTAILED AND TO BE ROUTED/CONNECTED TO DESIGNATED LOCATION.  
2) ALL THROTTLE CONTROL WIRES ARE INCLUDED/COMPATIBLE WITH UP TO 3 THROTTLE SWITCHES; HOWEVER, NOT ALL APPLICATIONS WILL UTILIZE ANY OR ALL OF THE WIRES.  
3) (1) MEANS CAVITY IS FILLED WITH A SEAL PLUG K.M. P/N 13-445  
4) CORRESPONDING IDENTIFICATION NUMERICAL CONTACT POINTS ARE IN COMMON FOR TERMINAL STRIP K.M. P/N 11-069 AND 11-070  
5) CIRCLED RD/BK SYMBOLS INDICATE THE WIRE IS TWISTED PAIR.

# Step 7: Trim Control Wiring Installation (continued)

## KONRAD MARINE INC. TRIM SYSTEM ELECTRICAL DRAWING (24 VOLT) 600B SINGLE DRIVE

AS OF 01 APRIL 2021  
REVISION 1 MAY 2016  
SENSOR UPDATE  
K.M. P/N 31-193

ORIGINAL SENSOR K.M. P/N 31-053  
WAS YL (NOW WT)-SIGNAL (+)  
WAS BL (NOW BR)-GROUND (-)

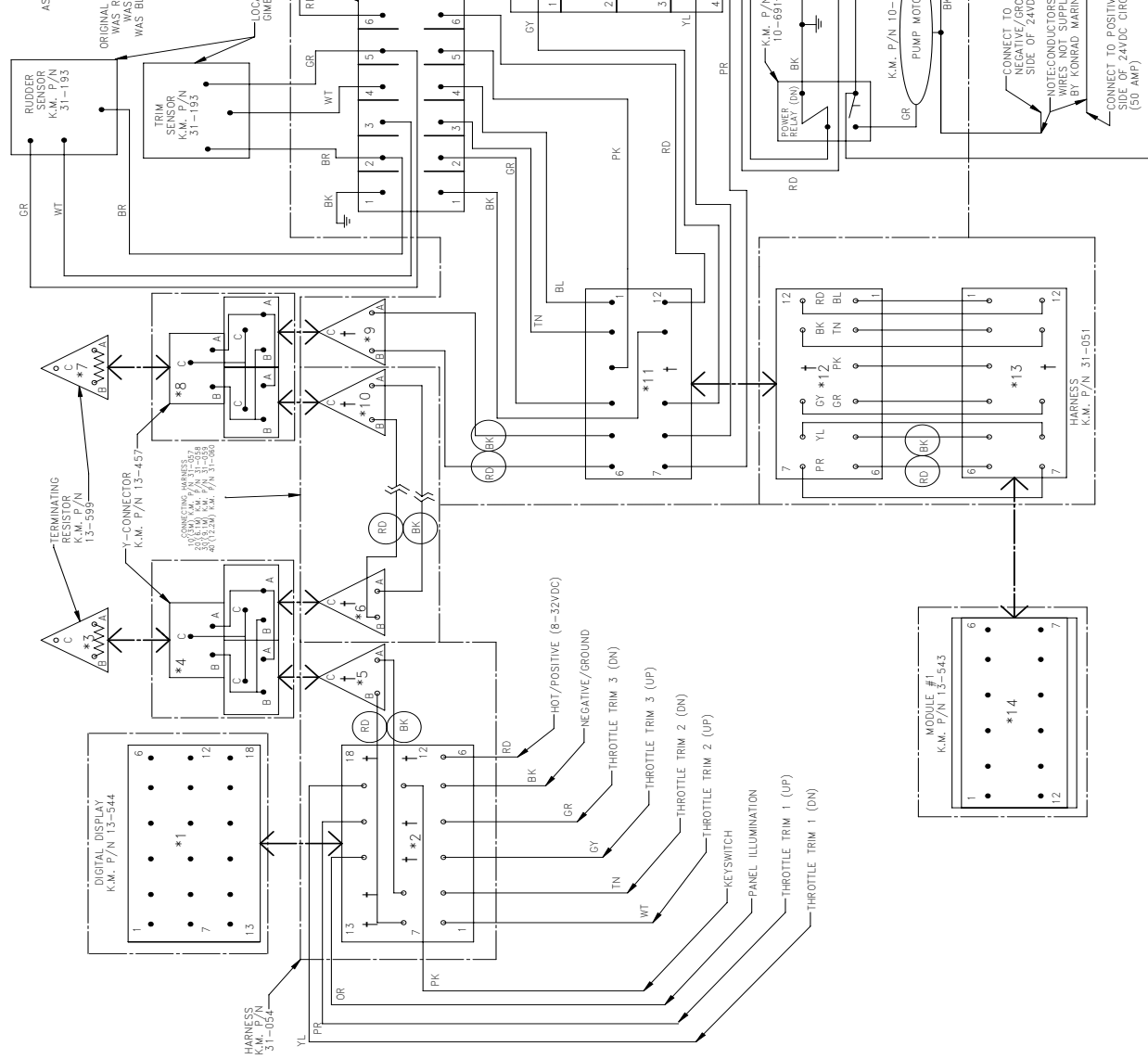

CONNECTOR	DESCRIPTION	WIRING CONNECTOR
*1	18 CAVITY FEMALE	*2
*2	18 CAVITY MALE	*1
*3	3 CAVITY MALE	*4
*4	3 CAVIT.3. WXY FEMALE Y	*3,*5,*6
*5	3 CAVITY MALE	*4
*6	3 CAVITY MALE	*4
*7	3 CAVITY MALE	*4
*8	3 CAVIT.3. WXY FEMALE Y	*7,*9,*10
*9	3 CAVITY MALE	*8
*10	3 CAVITY MALE	*8
*11	12 CAVITY FEMALE	*12
*12	12 CAVITY MALE	*11
*13	12 CAVITY MALE	*14
*14	12 CAVITY FEMALE	*13

NOTES FOR HARNESS K.M. P/N 31-054:  
1) WIRE IDENTIFICATIONS ARE LABELED AS: BK=BLACK, BL=BLUE, RD=RED, PR=PURPLE, GR=GREEN, OR=ORANGE, WT=WHITE, GY=GRAY, YL=YELLOW, TN=TAN, BR=BROWN, PK=PINK  
2) ALL WIRES PASSING THROUGH THE CONNECTORS REMAIN THE SAME COLOR  
3) ALL THROTTLE CONTROL WIRES ARE INCLUDED (COMPATIBLE WITH UP TO 3 THROTTLE TRIM SWITCHES); HOWEVER, NOT ALL APPLICATIONS WILL UTILIZE ANY OR ALL OF THE WIRES.  
4) WIRING POINTS ARE LABELED ON THE ORIGINAL P/N 31-053 HARNESS. WIRING POINTS ARE IN COMMON FOR TERMINAL STRIP K.M. P/N 11-069 AND 11-070  
5) CIRCLED RD BK SYMBOLS INDICATE THE WIRE IS TWISTED PAIR.

DRAWING BY A.G.  
AUGUST 2015  
REVISION 1 MAY 2016  
REVISION 2 APRIL 2021 (S.C.)

# Step 7: Trim Control Wiring Installation (continued)

# KONRAD

## SINGLE WIRING

### Single Drive, Dual Helm

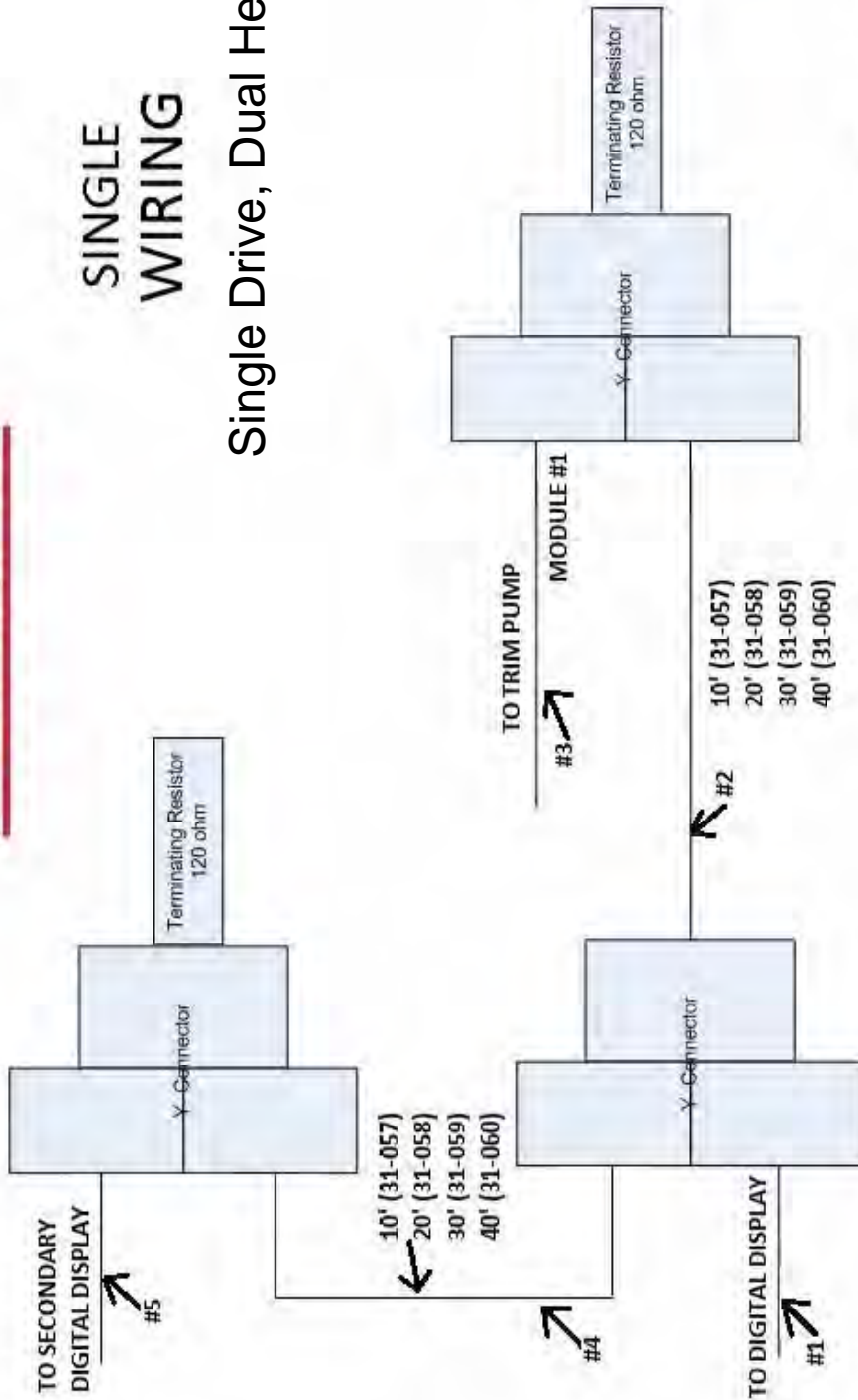

#### SHIPPING TAG #'S

- #1 #4
- #2 #5
- #3 #3

Note:  
 All Y-CONNECTORS HAVE 3 PORTS (2 TRIANGLE WEDGES PORTS, 1 CIRCLE WEDGE PORT). ALL ACCESSORIES (DISPLAY, TRIM PUMP) CAN-BUS LINES HAVE CIRCLE WEDGES(ORANGE) THAT PLUG INTO CORRESPONDING PORT ON THE Y-CONNECTOR. ALL JUMPER HARNESSES HAVE TRIANGLE WEDGES(BLUE) THAT PLUG INTO CORRESPONDING PORT ON THE Y-CONNECTORS.





# Step 7: Trim Control Wiring Installation (continued)

**KONRAD MARINE INC.**  
**TRIM SYSTEM ELECTRICAL**  
**DRAWING (24 VOLT) 600B**  
**SINGLE DRIVE, DUAL HELM**

AS OF 01 APRIL 2021  
 RIDDER/TRIM  
 SENSOR UPDATE  
 K.M. P/N 31-193  
 ORIGINAL SENSOR K.M. P/N 31-055  
 WAS RD (NOW GR)-POWER (+)  
 WAS YL (NOW WT)-SIGNAL  
 WAS BL (NOW BR)-GROUND (-)

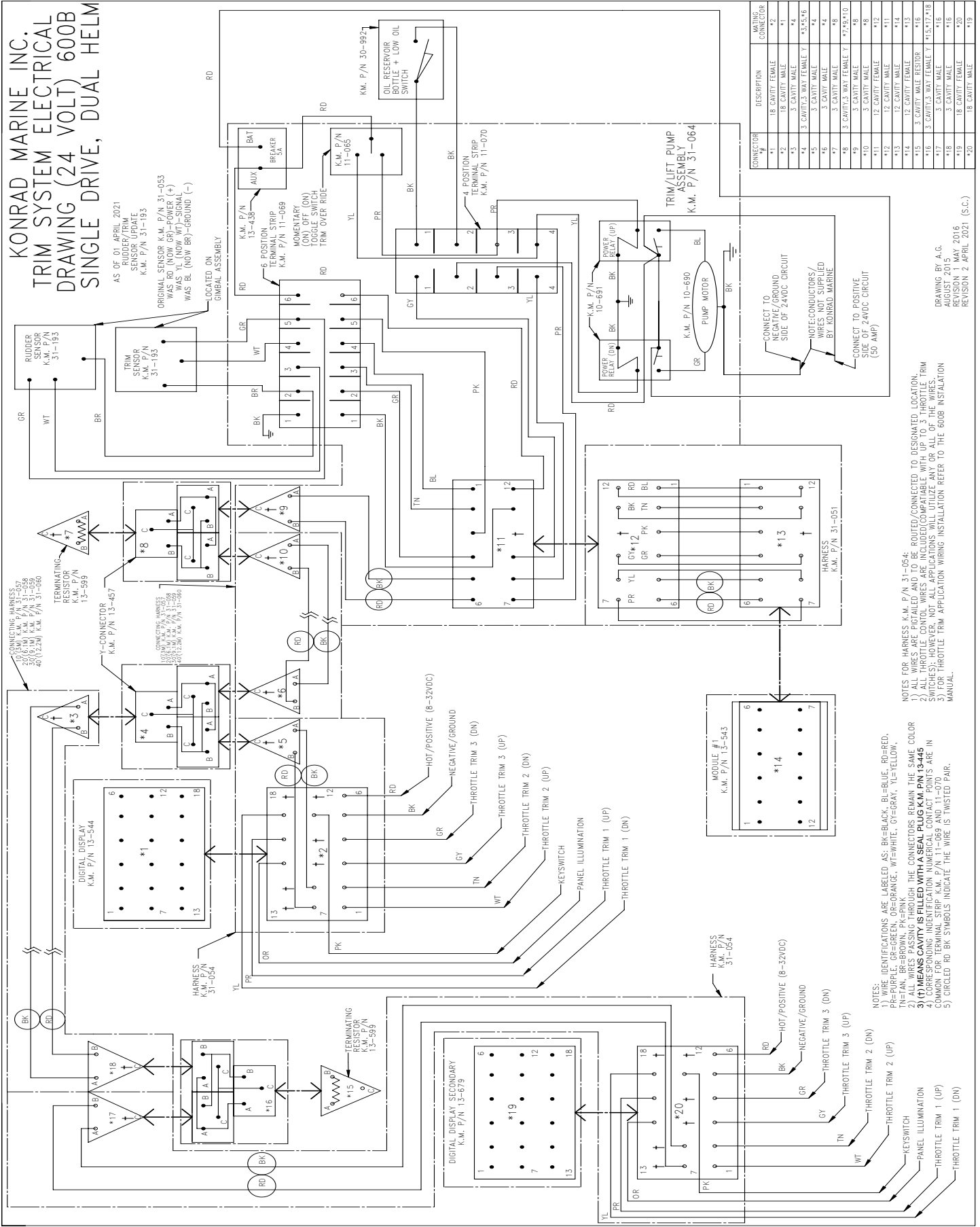

LOCATED ON GIMBAL ASSEMBLY

CONNECTING HARNESS 27  
 20 (6.0V) K.M. P/N 31-058  
 21 (6.0V) K.M. P/N 31-058  
 40 (12.2V) K.M. P/N 31-060

TERMINATING RESISTOR  
 K.M. P/N 13-589

Y-CONNECTOR  
 K.M. P/N 13-457

CONNECTING HARNESS 28  
 20 (6.0V) K.M. P/N 31-058  
 21 (6.0V) K.M. P/N 31-058  
 40 (12.2V) K.M. P/N 31-060

TRIM/LIFT PUMP ASSEMBLY  
 K.M. P/N 31-064

TRIM SENSOR  
 K.M. P/N 31-185

RIDDER SENSOR  
 K.M. P/N 31-193

POWER RELAY (UP)  
 K.M. P/N 10-681

PUMP MOTOR  
 K.M. P/N 10-690

CONNECT TO NEGATIVE/GROUND SIDE OF 24VDC CIRCUIT

NOTE-CONNECTORS/WIRES NOT SUPPLIED BY KONRAD MARINE

CONNECT TO POSITIVE SIDE OF 24VDC CIRCUIT (50 AMP)

CONNECT TO POSITIVE SIDE OF 24VDC CIRCUIT (50 AMP)

HARNESS K.M. P/N 31-051

MODULE #1  
 K.M. P/N 13-543

DIGITAL DISPLAY  
 K.M. P/N 13-544

DIGITAL DISPLAY SECONDARY  
 K.M. P/N 13-679

THROTTLE TRIM 3 (UP)

THROTTLE TRIM 3 (DN)

THROTTLE TRIM 2 (UP)

THROTTLE TRIM 2 (DN)

THROTTLE TRIM 1 (UP)

THROTTLE TRIM 1 (DN)

KEYSWITCH

PANEL ILLUMINATION

KEYSWITCH

PANEL ILLUMINATION

THROTTLE TRIM 1 (UP)

THROTTLE TRIM 1 (DN)

THROTTLE TRIM 2 (UP)

THROTTLE TRIM 2 (DN)

THROTTLE TRIM 3 (UP)

THROTTLE TRIM 3 (DN)

HOT/POSITIVE (8-32VDC)

NEGATIVE/GROUND

HOT/POSITIVE (8-32VDC)

NEGATIVE/GROUND

CONNECTING HARNESS 29  
 20 (6.0V) K.M. P/N 31-058  
 21 (6.0V) K.M. P/N 31-058  
 40 (12.2V) K.M. P/N 31-060

TERMINATING RESISTOR  
 K.M. P/N 13-589

CONNECTING HARNESS 30  
 20 (6.0V) K.M. P/N 31-058  
 21 (6.0V) K.M. P/N 31-058  
 40 (12.2V) K.M. P/N 31-060

TERMINATING RESISTOR  
 K.M. P/N 13-589

CONNECTING HARNESS 31  
 20 (6.0V) K.M. P/N 31-058  
 21 (6.0V) K.M. P/N 31-058  
 40 (12.2V) K.M. P/N 31-060

TERMINATING RESISTOR  
 K.M. P/N 13-589

CONNECTING HARNESS 32  
 20 (6.0V) K.M. P/N 31-058  
 21 (6.0V) K.M. P/N 31-058  
 40 (12.2V) K.M. P/N 31-060

TERMINATING RESISTOR  
 K.M. P/N 13-589

CONNECTING HARNESS 33  
 20 (6.0V) K.M. P/N 31-058  
 21 (6.0V) K.M. P/N 31-058  
 40 (12.2V) K.M. P/N 31-060

TERMINATING RESISTOR  
 K.M. P/N 13-589

CONNECTING HARNESS 34  
 20 (6.0V) K.M. P/N 31-058  
 21 (6.0V) K.M. P/N 31-058  
 40 (12.2V) K.M. P/N 31-060

TERMINATING RESISTOR  
 K.M. P/N 13-589

CONNECTING HARNESS 35  
 20 (6.0V) K.M. P/N 31-058  
 21 (6.0V) K.M. P/N 31-058  
 40 (12.2V) K.M. P/N 31-060

TERMINATING RESISTOR  
 K.M. P/N 13-589

CONNECTING HARNESS 36  
 20 (6.0V) K.M. P/N 31-058  
 21 (6.0V) K.M. P/N 31-058  
 40 (12.2V) K.M. P/N 31-060

TERMINATING RESISTOR  
 K.M. P/N 13-589

CONNECTING HARNESS 37  
 20 (6.0V) K.M. P/N 31-058  
 21 (6.0V) K.M. P/N 31-058  
 40 (12.2V) K.M. P/N 31-060

TERMINATING RESISTOR  
 K.M. P/N 13-589

CONNECTING HARNESS 38  
 20 (6.0V) K.M. P/N 31-058  
 21 (6.0V) K.M. P/N 31-058  
 40 (12.2V) K.M. P/N 31-060

TERMINATING RESISTOR  
 K.M. P/N 13-589

CONNECTING HARNESS 39  
 20 (6.0V) K.M. P/N 31-058  
 21 (6.0V) K.M. P/N 31-058  
 40 (12.2V) K.M. P/N 31-060

TERMINATING RESISTOR  
 K.M. P/N 13-589

CONNECTING HARNESS 40  
 20 (6.0V) K.M. P/N 31-058  
 21 (6.0V) K.M. P/N 31-058  
 40 (12.2V) K.M. P/N 31-060

TERMINATING RESISTOR  
 K.M. P/N 13-589

CONNECTING HARNESS 41  
 20 (6.0V) K.M. P/N 31-058  
 21 (6.0V) K.M. P/N 31-058  
 40 (12.2V) K.M. P/N 31-060

TERMINATING RESISTOR  
 K.M. P/N 13-589

CONNECTING HARNESS 42  
 20 (6.0V) K.M. P/N 31-058  
 21 (6.0V) K.M. P/N 31-058  
 40 (12.2V) K.M. P/N 31-060

TERMINATING RESISTOR  
 K.M. P/N 13-589

CONNECTING HARNESS 43  
 20 (6.0V) K.M. P/N 31-058  
 21 (6.0V) K.M. P/N 31-058  
 40 (12.2V) K.M. P/N 31-060

TERMINATING RESISTOR  
 K.M. P/N 13-589

CONNECTING HARNESS 44  
 20 (6.0V) K.M. P/N 31-058  
 21 (6.0V) K.M. P/N 31-058  
 40 (12.2V) K.M. P/N 31-060

TERMINATING RESISTOR  
 K.M. P/N 13-589

CONNECTING HARNESS 45  
 20 (6.0V) K.M. P/N 31-058  
 21 (6.0V) K.M. P/N 31-058  
 40 (12.2V) K.M. P/N 31-060

TERMINATING RESISTOR  
 K.M. P/N 13-589

CONNECTING HARNESS 46  
 20 (6.0V) K.M. P/N 31-058  
 21 (6.0V) K.M. P/N 31-058  
 40 (12.2V) K.M. P/N 31-060

TERMINATING RESISTOR  
 K.M. P/N 13-589

CONNECTING HARNESS 47  
 20 (6.0V) K.M. P/N 31-058  
 21 (6.0V) K.M. P/N 31-058  
 40 (12.2V) K.M. P/N 31-060

TERMINATING RESISTOR  
 K.M. P/N 13-589

CONNECTING HARNESS 48  
 20 (6.0V) K.M. P/N 31-058  
 21 (6.0V) K.M. P/N 31-058  
 40 (12.2V) K.M. P/N 31-060

TERMINATING RESISTOR  
 K.M. P/N 13-589

CONNECTING HARNESS 49  
 20 (6.0V) K.M. P/N 31-058  
 21 (6.0V) K.M. P/N 31-058  
 40 (12.2V) K.M. P/N 31-060

TERMINATING RESISTOR  
 K.M. P/N 13-589

CONNECTING HARNESS 50  
 20 (6.0V) K.M. P/N 31-058  
 21 (6.0V) K.M. P/N 31-058  
 40 (12.2V) K.M. P/N 31-060

TERMINATING RESISTOR  
 K.M. P/N 13-589

CONNECTING HARNESS 51  
 20 (6.0V) K.M. P/N 31-058  
 21 (6.0V) K.M. P/N 31-058  
 40 (12.2V) K.M. P/N 31-060

TERMINATING RESISTOR  
 K.M. P/N 13-589

CONNECTING HARNESS 52  
 20 (6.0V) K.M. P/N 31-058  
 21 (6.0V) K.M. P/N 31-058  
 40 (12.2V) K.M. P/N 31-060

TERMINATING RESISTOR  
 K.M. P/N 13-589

CONNECTING HARNESS 53  
 20 (6.0V) K.M. P/N 31-058  
 21 (6.0V) K.M. P/N 31-058  
 40 (12.2V) K.M. P/N 31-060

TERMINATING RESISTOR  
 K.M. P/N 13-589

CONNECTING HARNESS 54  
 20 (6.0V) K.M. P/N 31-058  
 21 (6.0V) K.M. P/N 31-058  
 40 (12.2V) K.M. P/N 31-060

TERMINATING RESISTOR  
 K.M. P/N 13-589

CONNECTING HARNESS 55  
 20 (6.0V) K.M. P/N 31-058  
 21 (6.0V) K.M. P/N 31-058  
 40 (12.2V) K.M. P/N 31-060

TERMINATING RESISTOR  
 K.M. P/N 13-589

CONNECTING HARNESS 56  
 20 (6.0V) K.M. P/N 31-058  
 21 (6.0V) K.M. P/N 31-058  
 40 (12.2V) K.M. P/N 31-060

TERMINATING RESISTOR  
 K.M. P/N 13-589

CONNECTING HARNESS 57  
 20 (6.0V) K.M. P/N 31-058  
 21 (6.0V) K.M. P/N 31-058  
 40 (12.2V) K.M. P/N 31-060

TERMINATING RESISTOR  
 K.M. P/N 13-589

CONNECTING HARNESS 58  
 20 (6.0V) K.M. P/N 31-058  
 21 (6.0V) K.M. P/N 31-058  
 40 (12.2V) K.M. P/N 31-060

TERMINATING RESISTOR  
 K.M. P/N 13-589

CONNECTING HARNESS 59  
 20 (6.0V) K.M. P/N 31-058  
 21 (6.0V) K.M. P/N 31-058  
 40 (12.2V) K.M. P/N 31-060

TERMINATING RESISTOR  
 K.M. P/N 13-589

CONNECTING HARNESS 60  
 20 (6.0V) K.M. P/N 31-058  
 21 (6.0V) K.M. P/N 31-058  
 40 (12.2V) K.M. P/N 31-060

TERMINATING RESISTOR  
 K.M. P/N 13-589

CONNECTING HARNESS 61  
 20 (6.0V) K.M. P/N 31-058  
 21 (6.0V) K.M. P/N 31-058  
 40 (12.2V) K.M. P/N 31-060

TERMINATING RESISTOR  
 K.M. P/N 13-589

CONNECTING HARNESS 62  
 20 (6.0V) K.M. P/N 31-058  
 21 (6.0V) K.M. P/N 31-058  
 40 (12.2V) K.M. P/N 31-060

TERMINATING RESISTOR  
 K.M. P/N 13-589

CONNECTING HARNESS 63  
 20 (6.0V) K.M. P/N 31-058  
 21 (6.0V) K.M. P/N 31-058  
 40 (12.2V) K.M. P/N 31-060

TERMINATING RESISTOR  
 K.M. P/N 13-589

CONNECTING HARNESS 64  
 20 (6.0V) K.M. P/N 31-058  
 21 (6.0V) K.M. P/N 31-058  
 40 (12.2V) K.M. P/N 31-060

TERMINATING RESISTOR  
 K.M. P/N 13-589

CONNECTING HARNESS 65  
 20 (6.0V) K.M. P/N 31-058  
 21 (6.0V) K.M. P/N 31-058  
 40 (12.2V) K.M. P/N 31-060

TERMINATING RESISTOR  
 K.M. P/N 13-589

CONNECTING HARNESS 66  
 20 (6.0V) K.M. P/N 31-058  
 21 (6.0V) K.M. P/N 31-058  
 40 (12.2V) K.M. P/N 31-060

TERMINATING RESISTOR  
 K.M. P/N 13-589

CONNECTING HARNESS 67  
 20 (6.0V) K.M. P/N 31-058  
 21 (6.0V) K.M. P/N 31-058  
 40 (12.2V) K.M. P/N 31-060

TERMINATING RESISTOR  
 K.M. P/N 13-589

CONNECTING HARNESS 68  
 20 (6.0V) K.M. P/N 31-058  
 21 (6.0V) K.M. P/N 31-058  
 40 (12.2V) K.M. P/N 31-060

TERMINATING RESISTOR  
 K.M. P/N 13-589

CONNECTING HARNESS 69  
 20 (6.0V) K.M. P/N 31-058  
 21 (6.0V) K.M. P/N 31-058  
 40 (12.2V) K.M. P/N 31-060

TERMINATING RESISTOR  
 K.M. P/N 13-589

CONNECTING HARNESS 70  
 20 (6.0V) K.M. P/N 31-058  
 21 (6.0V) K.M. P/N 31-058  
 40 (12.2V) K.M. P/N 31-060

TERMINATING RESISTOR  
 K.M. P/N 13-589

CONNECTING HARNESS 71  
 20 (6.0V) K.M. P/N 31-058  
 21 (6.0V) K.M. P/N 31-058  
 40 (12.2V) K.M. P/N 31-060

TERMINATING RESISTOR  
 K.M. P/N 13-589

CONNECTING HARNESS 72  
 20 (6.0V) K.M. P/N 31-058  
 21 (6.0V) K.M. P/N 31-058  
 40 (12.2V) K.M. P/N 31-060

TERMINATING RESISTOR  
 K.M. P/N 13-589

CONNECTING HARNESS 73  
 20 (6.0V) K.M. P/N 31-058  
 21 (6.0V) K.M. P/N 31-058  
 40 (12.2V) K.M. P/N 31-060

TERMINATING RESISTOR  
 K.M. P/N 13-589

CONNECTING HARNESS 74  
 20 (6.0V) K.M. P/N 31-058  
 21 (6.0V) K.M. P/N 31-058  
 40 (12.2V) K.M. P/N 31-060

TERMINATING RESISTOR  
 K.M. P/N 13-589

CONNECTING HARNESS 75  
 20 (6.0V) K.M. P/N 31-058  
 21 (6.0V) K.M. P/N 31-058  
 40 (12.2V) K.M. P/N 31-060

TERMINATING RESISTOR  
 K.M. P/N 13-589

CONNECTING HARNESS 76  
 20 (6.0V) K.M. P/N 31-058  
 21 (6.0V) K.M. P/N 31-058  
 40 (12.2V) K.M. P/N 31-060

TERMINATING RESISTOR  
 K.M. P/N 13-589

CONNECTING HARNESS 77  
 20 (6.0V) K.M. P/N 31-058  
 21 (6.0V) K.M. P/N 31-058  
 40 (12.2V) K.M. P/N 31-060

TERMINATING RESISTOR  
 K.M. P/N 13-589

CONNECTING HARNESS 78  
 20 (6.0V) K.M. P/N 31-058  
 21 (6.0V) K.M. P/N 31-058  
 40 (12.2V) K.M. P/N 31-060

TERMINATING RESISTOR  
 K.M. P/N 13-589

CONNECTING HARNESS 79  
 20 (6.0V) K.M. P/N 31-058  
 21 (6.0V) K.M. P/N 31-058  
 40 (12.2V) K.M. P/N 31-060

TERMINATING RESISTOR  
 K.M. P/N 13-589

CONNECTING HARNESS 80  
 20 (6.0V) K.M. P/N 31-058  
 21 (6.0V) K.M. P/N 31-058  
 40 (12.2V) K.M. P/N 31-060

TERMINATING RESISTOR  
 K.M. P/N 13-589

CONNECTING HARNESS 81  
 20 (6.0V) K.M. P/N 31-058  
 21 (6.0V) K.M. P/N 31-058  
 40 (12.2V) K.M. P/N 31-060

TERMINATING RESISTOR  
 K.M. P/N 13-589

CONNECTING HARNESS 82  
 20 (6.0V) K.M. P/N 31-058  
 21 (6.0V) K.M. P/N 31-058  
 40 (12.2V) K.M. P/N 31-060

TERMINATING RESISTOR  
 K.M. P/N 13-589

CONNECTING HARNESS 83  
 20 (6.0V) K.M. P/N 31-058  
 21 (6.0V) K.M. P/N 31-058  
 40 (12.2V) K.M. P/N 31-060

TERMINATING RESISTOR  
 K.M. P/N 13-589

CONNECTING HARNESS 84  
 20 (6.0V) K.M. P/N 31-058  
 21 (6.0V) K.M. P/N 31-058  
 40 (12.2V) K.M. P/N 31-060

TERMINATING RESISTOR  
 K.M. P/N 13-589

CONNECTING HARNESS 85  
 20 (6.0V) K.M. P/N 31-058  
 21 (6.0V) K.M. P/N 31-058  
 40 (12.2V) K.M. P/N 31-060

TERMINATING RESISTOR  
 K.M. P/N 13-589

CONNECTING HARNESS 86  
 20 (6.0V) K.M. P/N 31-058  
 21 (6.0V) K.M. P/N 31-058  
 40 (12.2V) K.M. P/N 31-060

TERMINATING RESISTOR  
 K.M. P/N 13-589

CONNECTING HARNESS 87  
 20 (6.0V) K.M. P/N 31-058  
 21 (6.0V) K.M. P/N 31-058  
 40 (12.2V) K.M. P/N 31-060

TERMINATING RESISTOR  
 K.M. P/N 13-589

CONNECTING HARNESS 88  
 20 (6.0V) K.M. P/N 31-058  
 21 (6.0V) K.M. P/N 31-058  
 40 (12.2V) K.M. P/N 31-060

TERMINATING RESISTOR  
 K.M. P/N 13-589

CONNECTING HARNESS 89  
 20 (6.0V) K.M. P/N 31-058  
 21 (6.0V) K.M. P/N 31-058  
 40 (12.2V) K.M. P/N 31-060

TERMINATING RESISTOR  
 K.M. P/N 13-589

CONNECTING HARNESS 90  
 20 (6.0V) K.M. P/N 31-058  
 21 (6.0V) K.M. P/N 31-058  
 40 (12.2V) K.M. P/N 31-060

TERMINATING RESISTOR  
 K.M. P/N 13-589

CONNECTING HARNESS 91  
 20 (6.0V) K.M. P/N 31-058  
 21 (6.0V) K.M. P/N 31-058  
 40 (12.2V) K.M. P/N 31-060

TERMINATING RESISTOR  
 K.M. P/N 13-589

CONNECTING HARNESS 92  
 20 (6.0V) K.M. P/N 31-058  
 21 (6.0V) K.M. P/N 31-058  
 40 (12.2V) K.M. P/N 31-060

TERMINATING RESISTOR  
 K.M. P/N 13-589

CONNECTING HARNESS 93  
 20 (6.0V) K.M. P/N 31-058  
 21 (6.0V) K.M. P/N 31-058  
 40 (12.2V) K.M. P/N 31-060

TERMINATING RESISTOR  
 K.M. P/N 13-589

CONNECTING HARNESS 94  
 20 (6.0V) K.M. P/N 31-058  
 21 (6.0V) K.M. P/N 31-058  
 40 (12.2V) K.M. P/N 31-060

TERMINATING RESISTOR  
 K.M. P/N 13-589

CONNECTING HARNESS 95  
 20 (6.0V) K.M. P/N 31-058  
 21 (6.0V) K.M. P/N 31-058  
 40 (12.2V) K.M. P/N 31-060

TERMINATING RESISTOR  
 K.M. P/N 13-589

CONNECTING HARNESS 96  
 20 (6.0V) K.M. P/N 31-058  
 21 (6.0V) K.M. P/N 31-058  
 40 (12.2V) K.M. P/N 31-060

TERMINATING RESISTOR  
 K.M. P/N 13-589

CONNECTING HARNESS 97  
 20 (6.0V) K.M. P/N 31-058  
 21 (6.0V) K.M. P/N 31-058  
 40 (12.2V) K.M. P/N 31-060

TERMINATING RESISTOR  
 K.M. P/N 13-589

CONNECTING HARNESS 98  
 20 (6.0V) K.M. P/N 31-058  
 21 (6.0V) K.M. P/N 31-058  
 40 (12.2V) K.M. P/N 31-060

TERMINATING RESISTOR  
 K.M. P/N 13-589

CONNECTING HARNESS 99  
 20 (6.0V) K.M. P/N 31-058  
 21 (6.0V) K.M. P/N 31-058  
 40 (12.2V) K.M. P/N 31-060

TERMINATING RESISTOR  
 K.M. P/N 13-589

CONNECTING HARNESS 100  
 20 (6.0V) K.M. P/N 31-058  
 21 (6.0V) K.M. P/N 31-058  
 40 (12.2V) K.M. P/N 31-060

TERMINATING RESISTOR  
 K.M. P/N 13-589

NOTES FOR HARNESS K.M. P/N 31-054:

- 1) ALL WIRES ARE PIGTAILED AND TO BE ROUTED/CONNECTED TO DESIGNATED LOCATION.
- 2) ALL WIRES ARE PIGTAILED AND TO BE ROUTED/CONNECTED TO DESIGNATED LOCATION.
- 3) ALL WIRES ARE PIGTAILED AND TO BE ROUTED/CONNECTED TO DESIGNATED LOCATION.
- 4) MEANS CAVITY IS FILLED WITH A SEAL PLUG K.M. P/N 13-445
- 5) CORRESPONDING IDENTIFICATION NUMERICAL CONTACT POINTS ARE IN COMMON FOR TERMINAL STRIP K.M. P/N 11-069 AND 11-070
- 6) CIRCLED RD BK SYMBOLS INDICATE THE WIRE IS TWISTED PAIR.

NOTES:

- 1) WIRE IDENTIFICATIONS ARE LABELED AS: BK=BLACK, BL=BLUE, RD=RED, PR=PURPLE, GR=GREEN, OR=ORANGE, WT=WHITE, GY=GRAY, YL=YELLOW, TN=TEAL, BR=BROWN, PK=PINK
- 2) ALL WIRE IDENTIFICATIONS ARE LABELED AS: BK=BLACK, BL=BLUE, RD=RED, PR=PURPLE, GR=GREEN, OR=ORANGE, WT=WHITE, GY=GRAY, YL=YELLOW, TN=TEAL, BR=BROWN, PK=PINK
- 3) ALL WIRE IDENTIFICATIONS ARE LABELED AS: BK=BLACK, BL=BLUE, RD=RED, PR=PURPLE, GR=GREEN, OR=ORANGE, WT=WHITE, GY=GRAY, YL=YELLOW, TN=TEAL, BR=BROWN, PK=PINK
- 4) MEANS CAVITY IS FILLED WITH A SEAL PLUG K.M. P/N 13-445
- 5) CORRESPONDING IDENTIFICATION NUMERICAL CONTACT POINTS ARE IN COMMON FOR TERMINAL STRIP K.M. P/N 11-069 AND 11-070
- 6) CIRCLED RD BK SYMBOLS INDICATE THE WIRE IS TWISTED PAIR.

# Step 7: Trim Control Wiring Installation (continued)

# KONRAD

## TWIN WIRING

Twin Drives, Single Helm

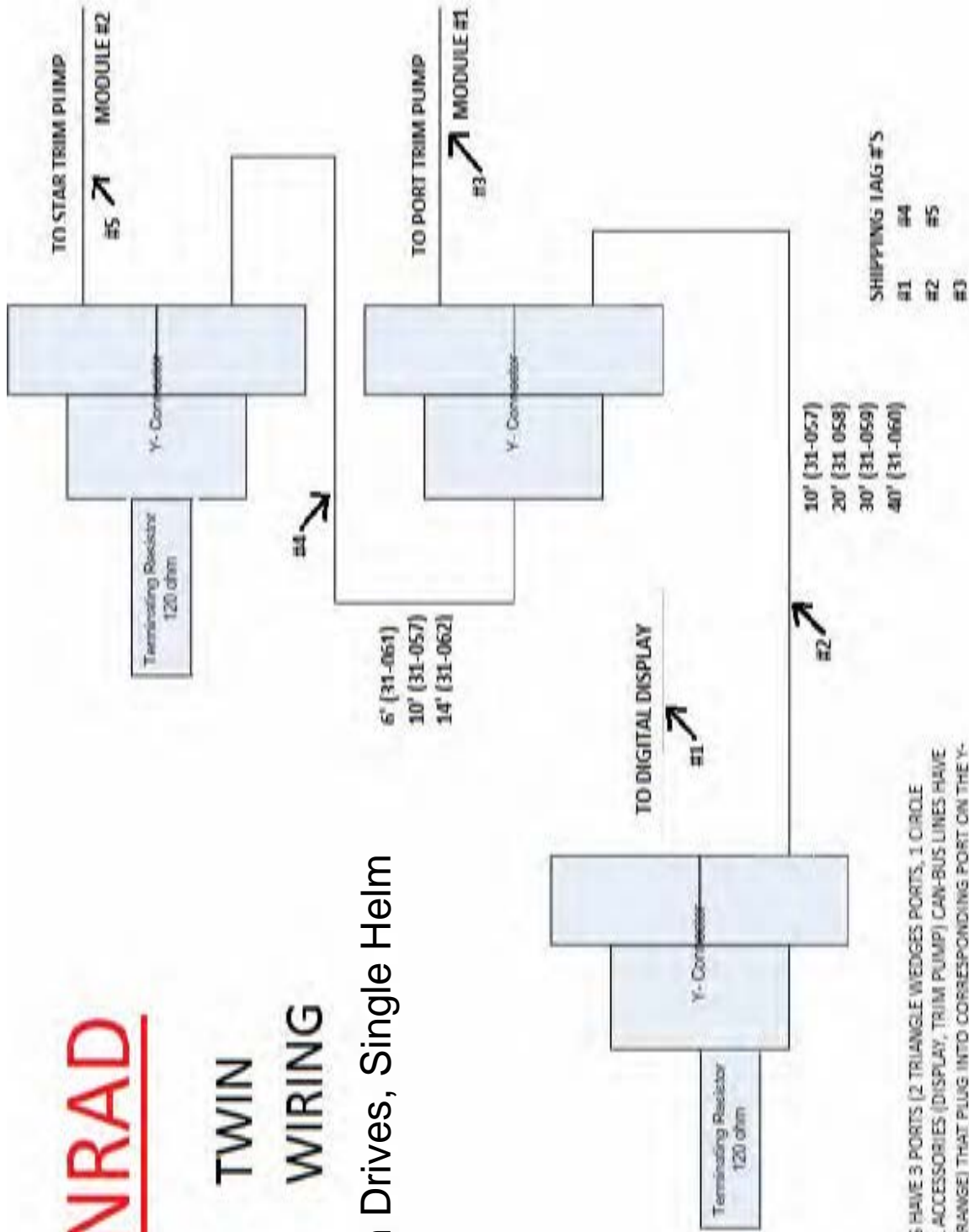

Note:  
All Y-CONNECTORS HAVE 3 PORTS (2 TRIANGLE WEDGES PORTS, 1 CIRCLE WEDGE PORT). ALL ACCESSORIES (DISPLAY, TRIM PUMP) CAN-BUS LINES HAVE CIRCLE WEDGES (ORANGE) THAT PLUG INTO CORRESPONDING PORT ON THE Y-CONNECTOR. ALL JUMPER HARNESSES HAVE TRIANGLE WEDGES (BLUE) THAT PLUG INTO CORRESPONDING PORT ON THE Y-CONNECTORS.



# Step 7: Trim Control Wiring Installation (continued)

## KONRAD MARINE INC. TRIM SYSTEM ELECTRICAL DRAWING (12 VOLT) 600B TWIN DRIVE

AS OF 01 APRIL 2021  
SENSOR UPDATE  
RUDDER/TRIM  
K.M. P/N 31-193  
ORIGINAL SENSOR K.M. P/N 31-053  
WAS YL (NOW WT)-SIGNAL (+)  
WAS BL (NOW BR)-GROUND (-)

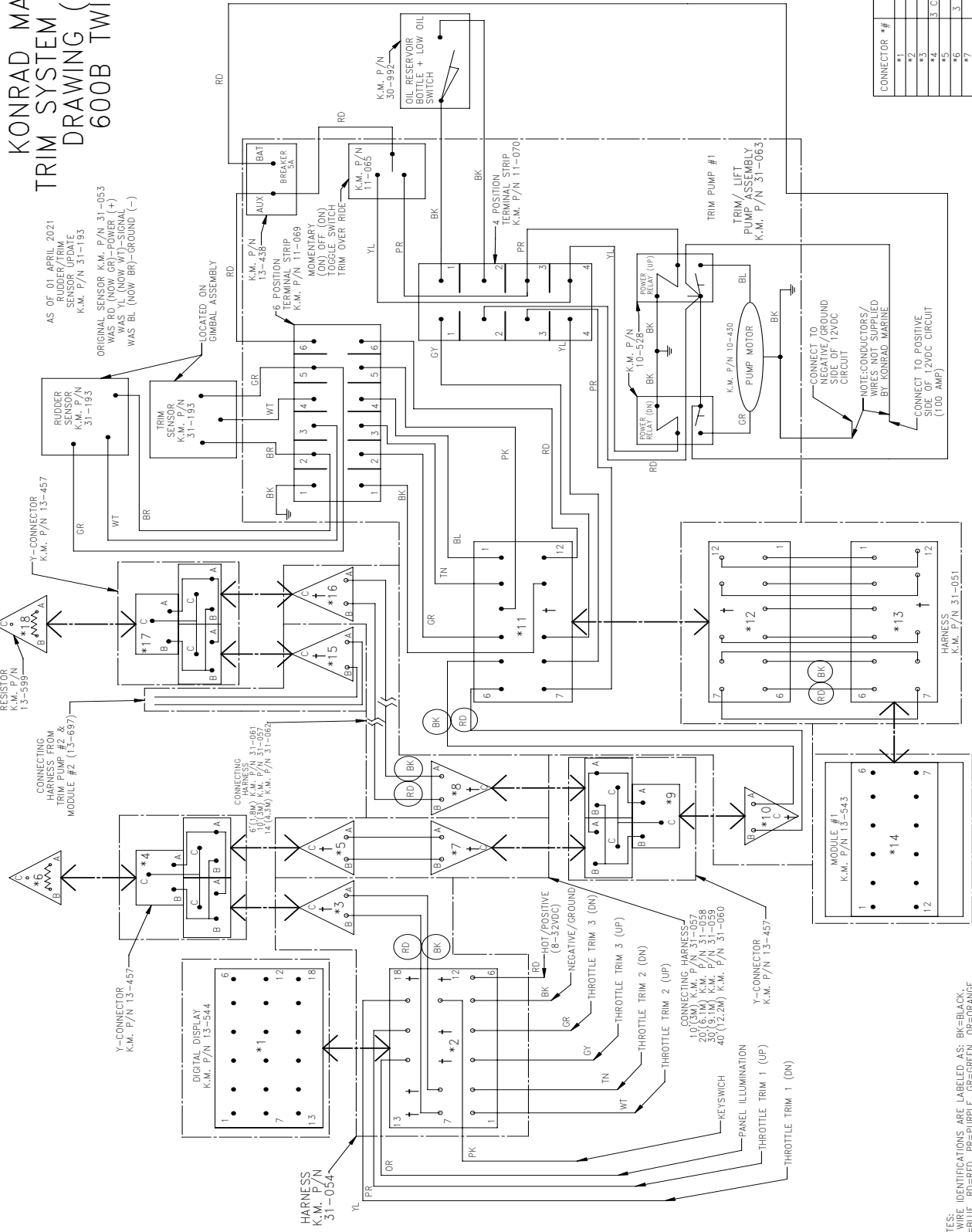

CONNECTOR #	DESCRIPTION	MATING CONNECTOR
*1	18 CAVITY FEMALE	*1
*2	18 CAVITY MALE	*2
*3	3 CAVITY MALE	*4
*4	3 CAVITY-3 WAY FEMALE	*3,*5,*6
*5	3 CAVITY MALE	*4
*6	3 CAVITY MALE RESISTOR	*4
*7	3 CAVITY MALE	*4
*8	3 CAVITY-3 WAY FEMALE	*7,*8,*10
*9	3 CAVITY MALE	*4
*10	3 CAVITY FEMALE	*12
*11	12 CAVITY MALE	*11
*12	12 CAVITY FEMALE	*11
*13	12 CAVITY MALE	*14
*14	12 CAVITY FEMALE	*13
*15	3 CAVITY MALE	*17
*16	3 CAVITY-3 WAY FEMALE	*15,*16,*18
*17	3 CAVITY MALE	*17
*18	3 CAVITY MALE RESISTOR	*17

DRAWING BY: A.G.  
REVISION 1: JUNE 2016  
REVISION 2: APRIL 2021 (S.C.)

- NOTES FOR HARNESS K.M. P/N 31-054:
- 1) ALL WIRES ARE PIGTAILED AND TO BE ROUTED/CONNECTED TO DESIGNATED LOCATION.
  - 2) ALL THROTTLE CONTROL WIRES ARE INCLUDED (COMPATIBLE WITH UP TO 3 THROTTLE TRIM SWITCHES); HOWEVER, NOT ALL APPLICATIONS WILL UTILIZE ANY OR ALL OF THE WIRES.
  - 3) (H) MEANS CAVITY IS FILLED WITH A SEAL PLUG K.M. P/N 13-445
  - 4) CORRESPONDING NUMERICAL CONTACT POINTS ARE IN COMMON FOR TERMINAL STRIP K.M. P/N 11-069 AND 11-070
  - 5) CIRCLED BK SYMBOLS INDICATE THE WIRE IS TWISTED PAIR.

# Step 7: Trim Control Wiring Installation (continued)

## KONRAD MARINE INC. TRIM SYSTEM ELECTRICAL DRAWING (24 VOLT) 600B TWIN DRIVE

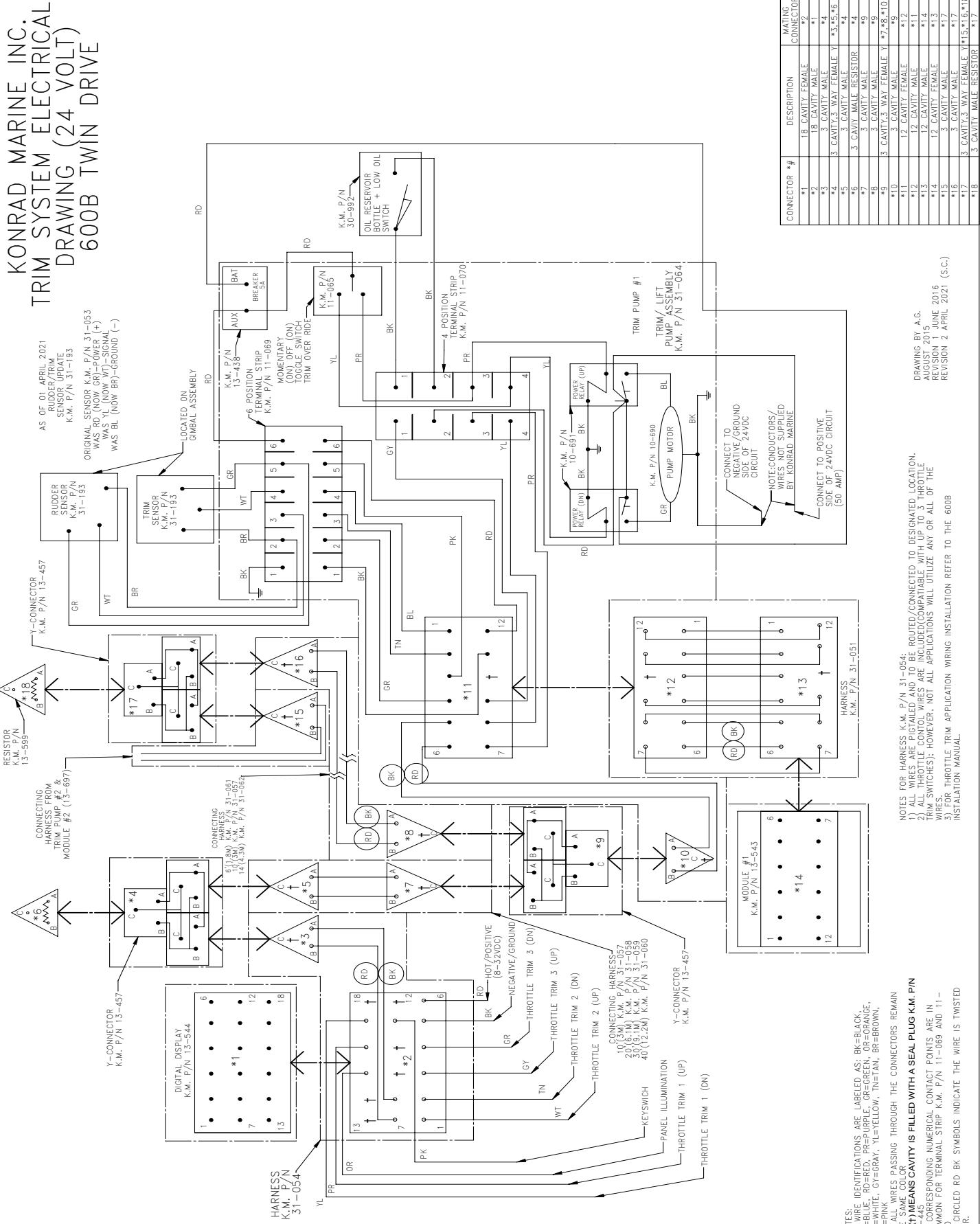

CONNECTOR #/ #	DESCRIPTION	MATING CONNECTOR
*1	18 CAVITY FEMALE	*1
*2	18 CAVITY MALE	*1
*3	3 CAVITY MALE	*4
*4	3 CAVITY 3-WAY FEMALE	*3, *5, *6
*5	3 CAVITY MALE	*4
*6	3 CAVITY MALE RESISTOR	*4
*7	3 CAVITY MALE	*4
*8	3 CAVITY MALE	*4
*9	3 CAVITY 3-WAY FEMALE	*7, *8, *10
*10	3 CAVITY MALE	*9
*11	12 CAVITY FEMALE	*12
*12	12 CAVITY MALE	*11
*13	12 CAVITY FEMALE	*14
*14	12 CAVITY MALE	*13
*15	3 CAVITY MALE	*17
*16	3 CAVITY MALE	*17
*17	3 CAVITY 3-WAY FEMALE	*15, *16, *18
*18	3 CAVITY MALE RESISTOR	*17

DRAWING BY: A.C.  
 REVISION 1: 01.15.2016  
 REVISION 2: 04.20.2021  
 REVISION 3: 04.20.2021

- NOTES FOR HARNESS K.M. P/N 31-054:
- 1) ALL WIRES ARE PIGTAILED AND TO BE ROUTED/CONNECTED TO DESIGNATED LOCATION.
  - 2) ALL THROTTLE CONTROL WIRES ARE INCLUDED (COMPATIBLE WITH UP TO 3 THROTTLE TRIM SWITCHES); HOWEVER, NOT ALL APPLICATIONS WILL UTILIZE ANY OR ALL OF THE WIRES.
  - 3) THROTTLE TRIM APPLICATION WIRING INSTALLATION REFER TO THE 600B INSTALLATION MANUAL.

- NOTES:
- 1) WIRE IDENTIFICATIONS ARE LABELED AS: BK=BLACK, BL=BLUE, RD=RED, PR=PURPLE, GR=GREEN, OR=ORANGE, WT=WHITE, GY=GRAY, YL=YELLOW, TN=TAN, BR=BROWN, PK=PINK. WIRES PASSING THROUGH THE CONNECTORS REMAIN THE SAME COLOR.
  - 2) (H) MEANS CAVITY IS FILLED WITH A SEAL PLUG K.M. P/N 13-445.
  - 3) CORRESPONDING NUMERICAL CONTACT POINTS ARE IN COMMON FOR TERMINAL STRIP K.M. P/N 11-069 AND 11-070.
  - 4) CIRCLED RD BK SYMBOLS INDICATE THE WIRE IS TWISTED PAIR.

# Step 7: Trim Control Wiring Installation (continued)

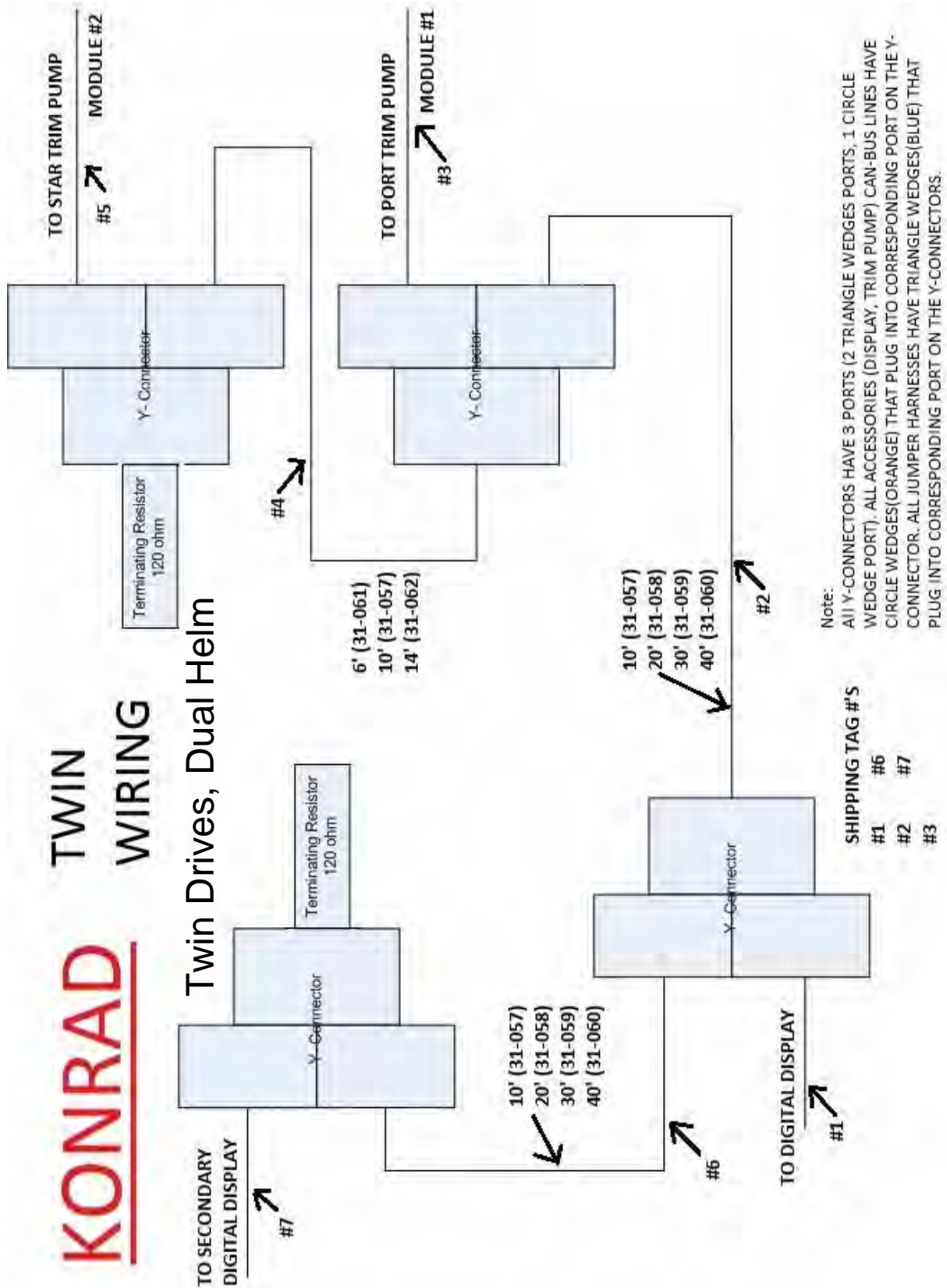





# Step 7: Trim Control Wiring Installation (continued)

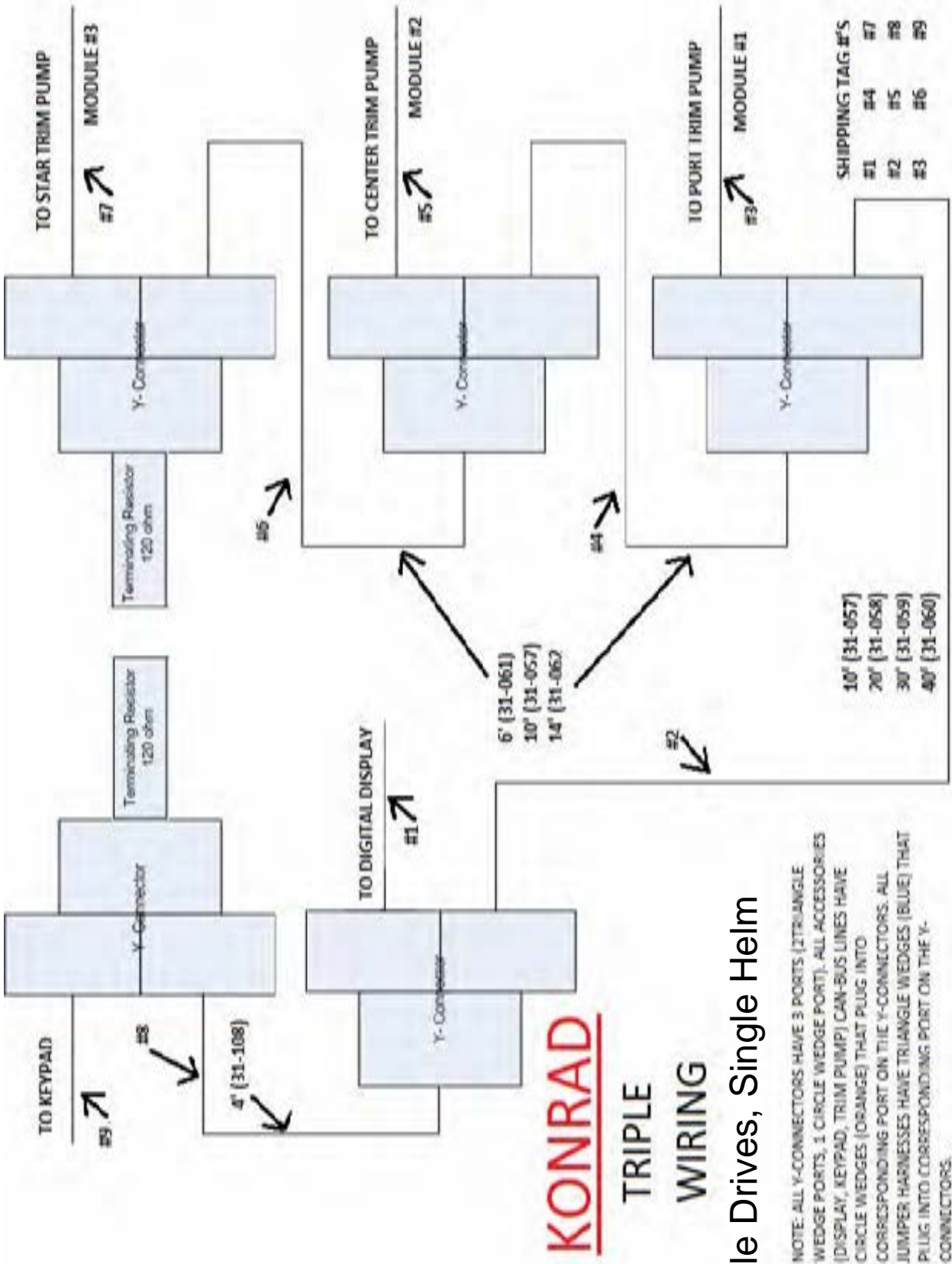

## Triple Drives, Single Helm









# Step 7: Trim Control Wiring Installation (continued)

## Triple Drives, Dual Helm

### KONRAD TRIPLE WIRING

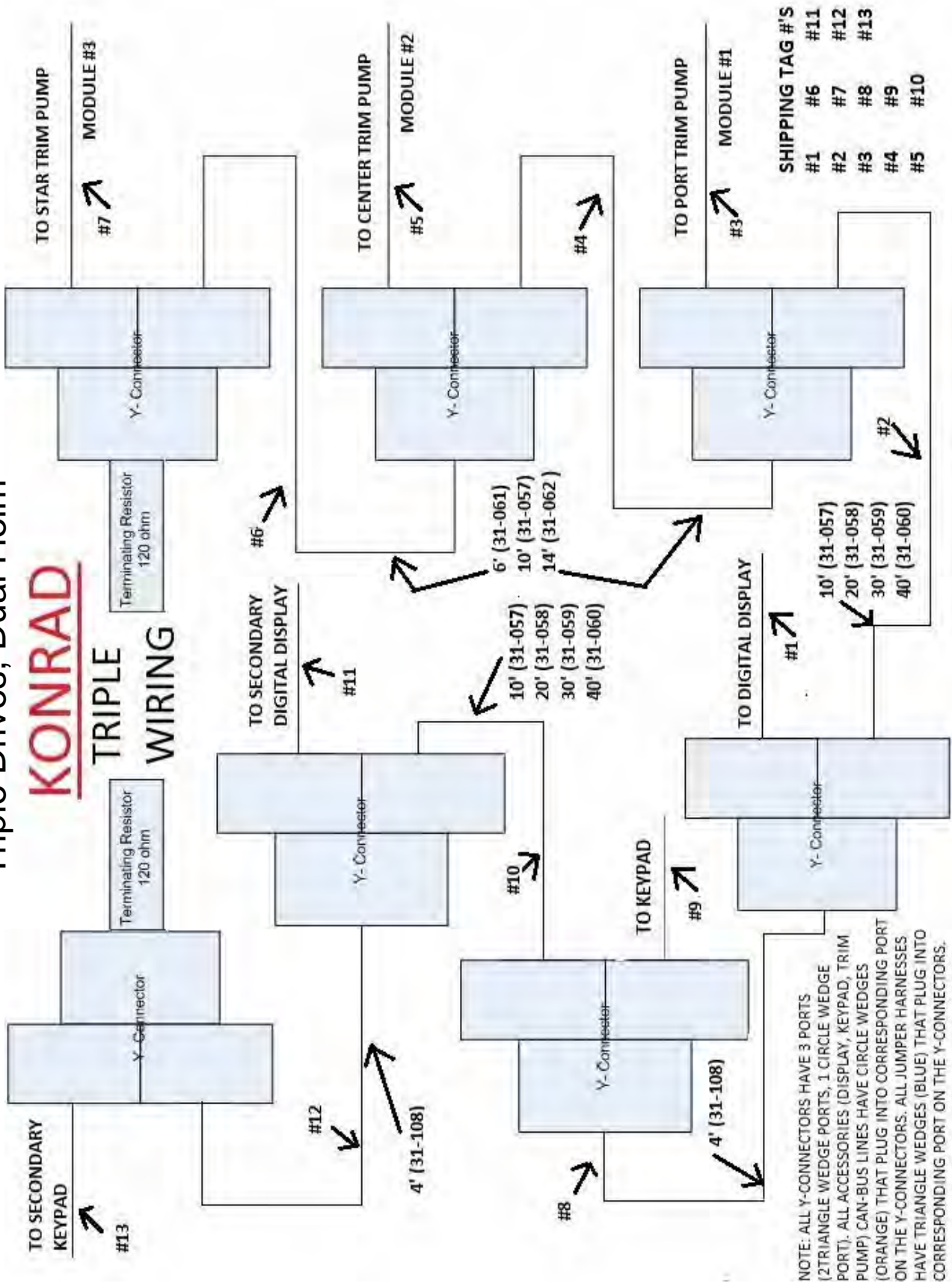

# Step 7: Trim Control Wiring Installation (continued)

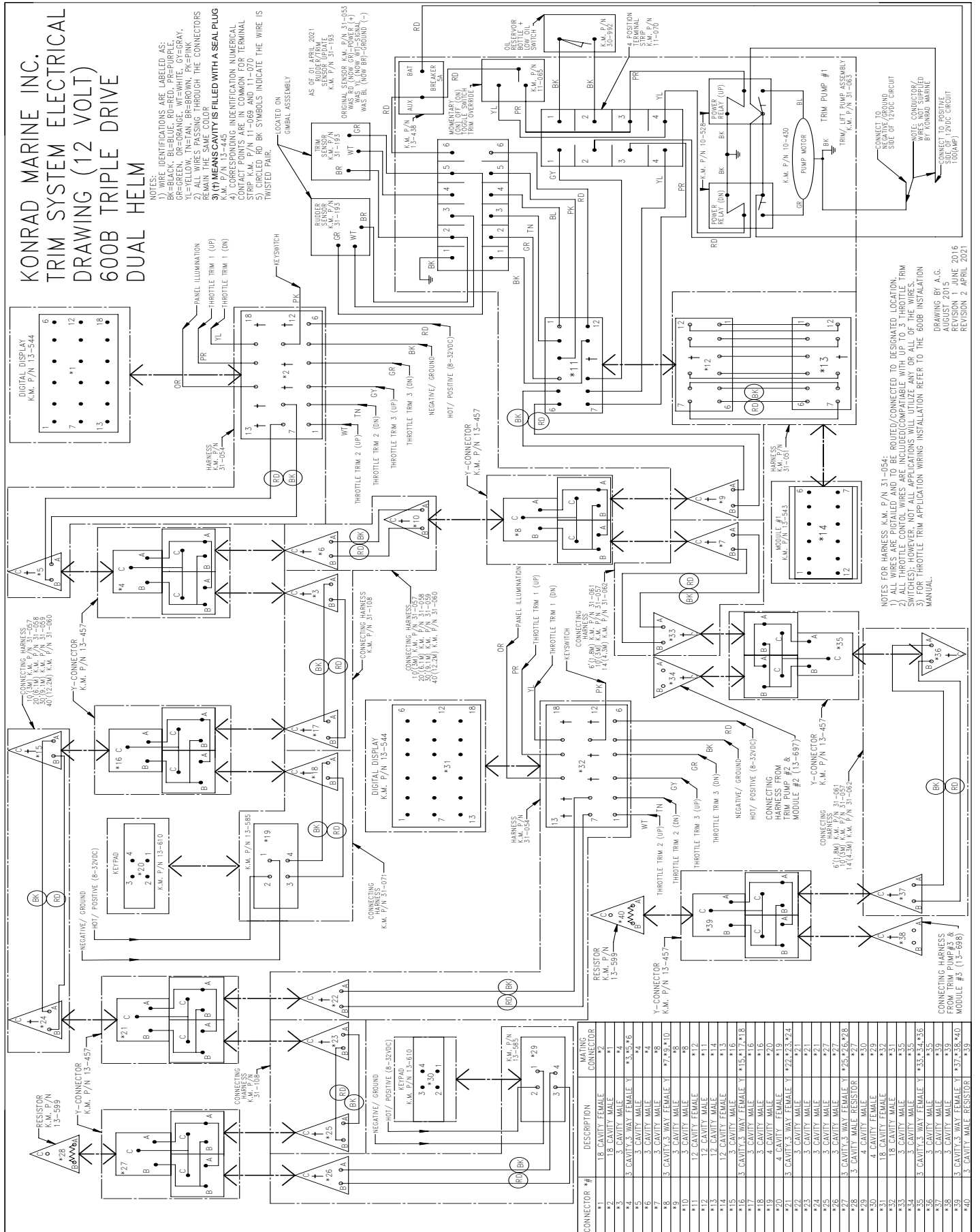

# Step 7: Trim Control Wiring Installation (continued)

## KONRAD MARINE INC. TRIM SYSTEM ELECTRICAL DRAWING (24 VOLT) 600B TRIPLE DRIVE DUAL HELM

- NOTES:  
1) WIRE IDENTIFICATIONS ARE LABELED AS:  
BK=BLACK, BL=BLUE, RD=RED, PR=PURPLE,  
GR=GREEN, YL=YELLOW, TN=TEAL, OR=GRAY,  
2) ALL WIRES PASSING THROUGH THE CONNECTORS  
REMAIN THE SAME COLOR  
3) (Y) MEANS CAVITY IS FILLED WITH A SEAL PLUG  
4) CORRESPONDING IDENTIFICATION NUMERICAL  
CONTACT POINTS ARE IN COMMON FOR TERMINAL  
STRIP K.M. P/N 11-069 AND 11-070  
5) CIRCLED RD BK SYMBOLS INDICATE THE WIRE IS  
TWISTED PAIR.

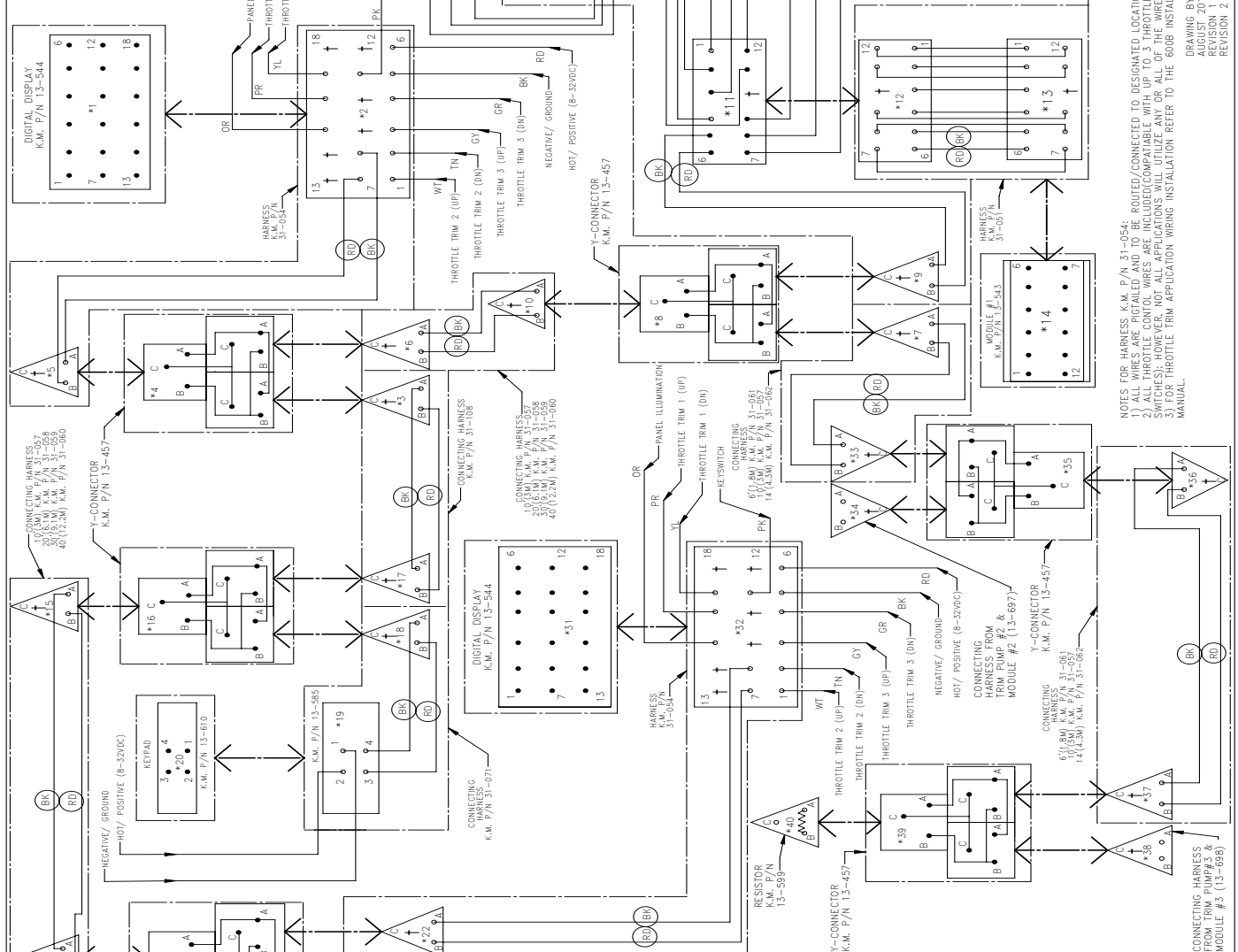

- NOTES FOR HARNESS K.M. P/N 31-054:  
1) ALL WIRES ARE CRIMPED AND TO BE ROUTED/CONNECTED TO DESIGNATED LOCATION.  
2) ALL THROTTLE CONTROL WIRES ARE INCLUDED/COMPATIBLE WITH UP TO 3 THROTTLE TRIM  
SWITCHES; HOWEVER, NOT ALL APPLICATIONS WILL UTILIZE ANY OR ALL OF THE WIRES.  
3) FOR THROTTLE TRIM APPLICATION WIRING INSTALLATION REFER TO THE 600B INSTALLATION  
MANUAL.  
DRAWING BY A.G.  
AUGUST 2015  
REVISION 1 JUNE 2016  
REVISION 2 APRIL 2021

CONNECTOR #	DESCRIPTION	MATING CONNECTOR
*1	18 CAVITY FEMALE	*2
*2	18 CAVITY MALE	*1
*3	3 CAVITY FEMALE	*4
*4	3 CAVITY MALE	*3
*5	3 CAVITY FEMALE	*6
*6	3 CAVITY MALE	*5
*7	3 CAVITY FEMALE	*8
*8	3 CAVITY MALE	*7
*9	3 CAVITY FEMALE	*8
*10	3 CAVITY MALE	*9
*11	3 CAVITY FEMALE	*11
*12	12 CAVITY MALE	*14
*13	12 CAVITY FEMALE	*13
*14	12 CAVITY MALE	*13
*15	3 CAVITY FEMALE	*16
*16	3 CAVITY MALE	*15
*17	3 CAVITY FEMALE	*17
*18	3 CAVITY MALE	*18
*19	4 CAVITY MALE	*20
*20	4 CAVITY FEMALE	*19
*21	3 CAVITY 3-WAY FEMALE	*22, *23, *24
*22	3 CAVITY MALE	*21
*23	3 CAVITY MALE	*21
*24	3 CAVITY MALE	*21
*25	3 CAVITY MALE	*27
*26	3 CAVITY MALE	*27
*27	3 CAVITY 3-WAY FEMALE	*25, *26, *28
*28	3 CAVITY MALE RESISTOR	*27
*29	4 CAVITY MALE	*30
*30	4 CAVITY FEMALE	*29
*31	18 CAVITY FEMALE	*32
*32	18 CAVITY MALE	*31
*33	3 CAVITY MALE	*35
*34	3 CAVITY MALE	*35
*35	3 CAVITY 3-WAY FEMALE	*33, *34, *36
*36	3 CAVITY MALE	*35
*37	3 CAVITY MALE	*38
*38	3 CAVITY MALE	*37
*39	3 CAVITY 3-WAY FEMALE	*37, *38, *40
*40	3 CAVITY MALE RESISTOR	*39

## Step 8: Trim Pump Filling/Bleeding Procedure

8.1 Fill the trim pump reservoir with Automatic Transmission Fluid type Dextron III or a non-foaming light hydraulic fluid.

*NOTE: If ATF Dextron III is not used, it is recommended that the trim cylinders be purged of any fluid since they are shipped new from Konrad with this fluid in them.*



8.2 Remove the down line hose from the trim pump, and place in a container to catch any purged fluid. The “up” line should already be attached from (Trim Pump Installation) earlier in this manual. Hold one finger over the “down” line port of the trim pump to prevent the intake of air.

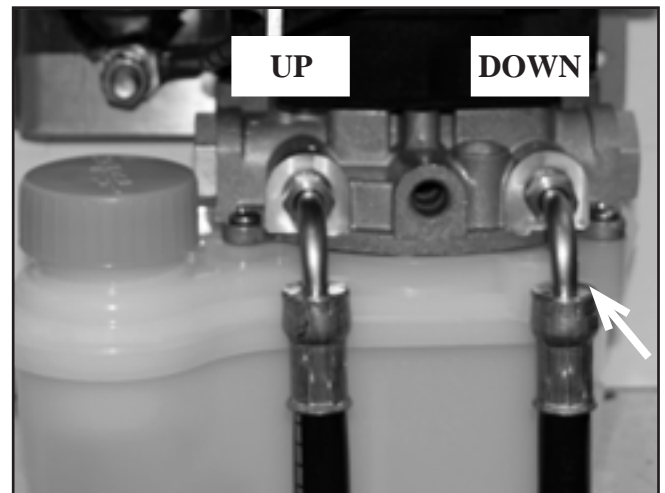

## Step 8: Trim Pump Filling/Bleeding Procedure (continued)

8.3 Trim the drive all the way up using the Trim Override toggle switch on the side of the trim pump.

**NOTE:** *Fluid may need to be added if the reservoir bottle goes below the minimum level.*

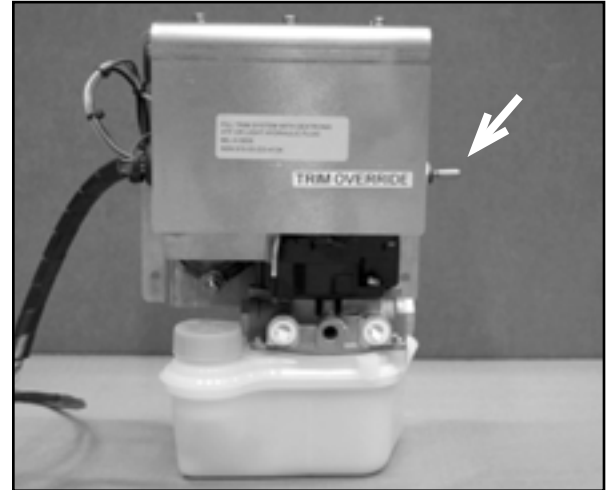

8.4 With the drive in the up position, reattach the down line to the trim pump.

8.5 Cycle the drive all the way to the down position and then all the way to the up position. Repeat this step three to four (3-4) times to purge any remaining air out of the system.

**NOTE:** *Re-check the fluid level of the reservoir. Add fluid if necessary.*

**NOTE:** *Check the entire trim system (inboard and outboard the transom) for leaks before proceeding.*

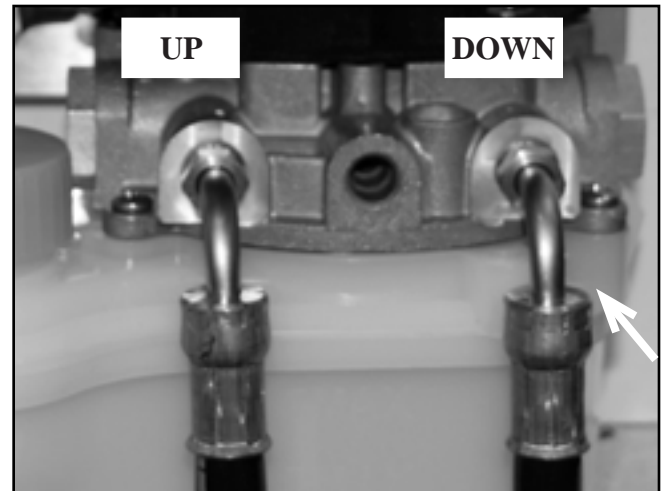



## Step 9: Trim Gauge Installation and Programming

9.1 Find a location at the helm to mount the trim control unit that is in plain view and within reach of the boat operator.

**NOTE:** The trim control unit can be mounted either flush, or with a RAM mount bracket RAM-B-238U and two 8-32 fasteners (Not Included) with a max depth of 0.340" and a minimum of 0.250" inches into the display. The template includes details for either installation.

9.2 Using the template provided drill or cut out location suitable for installing the trim control unit.

9.3 Once the trim control unit is installed in the desired location, the wire harness pigtail for the trim control can be connected to power and the unit calibrated.

**NOTE:** Battery or batteries must be disconnected while all electrical connections are being made.

**NOTE:** (See Trim System Electrical Drawing for your specific vessel configuration).

9.4 Secure any loose and excess wire harness.

9.5 Once power is supplied to the trim control unit, the Main Menu will appear. This is where all the settings can be adjusted for the vessel.

**NOTE:** If the system asks for a password, enter 1111 which is the default password set at the factory.

9.6 Use the center directional pad to navigate the main menu. Press the button below the word Enter to set your selection, follow the on screen instructions for set up.

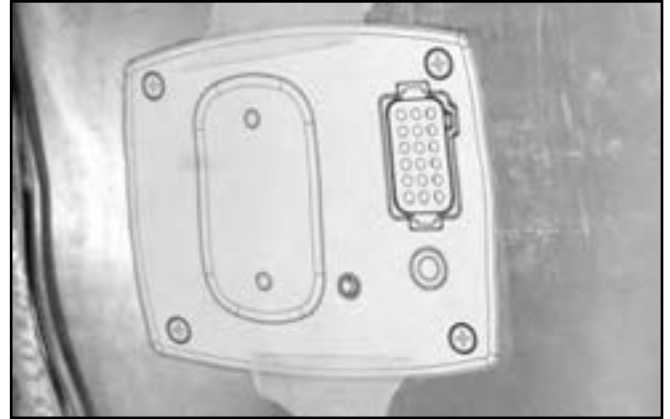



## Step 9: Trim Gauge Installation and Programming (continued)

9.7 The Adjust Backlight screen allows users to adjust the display lighting for both day and night. Use the arrow key to scroll, and adjust between the different settings. Press the enter key to save when done to go back to the Main Menu.



9.8 The Set Number of Drives screen allows users to tell the system how many drives are on the vessel so that each one will be displayed individually. Use the center arrow key to adjust the number of drives (1-3) and press the enter key when the correct number is shown in the square box.



9.9 The Module Configuration screen will be set up from the factory. **Do Not Attempt to Program!**

Location of the modules are critical since they are programmed to a specific drive location on the vessel.



9.10 The Calibration screen is where the drives trim and rudder position is set. Drive 1 will default to the port side drive in a twin and triple application. Follow the on screen instructions to set the trim and rudder parameters.

***NOTE: Make sure any external tie bars are removed and both the trim and steering systems have been properly filled with fluid and purged of air before performing this step.***



## Step 9: Trim Gauge Installation and Programming (continued)

**NOTE:** Zero trim position is when the cavitation plate is level.

When measuring for Zero trim position, the distance is measured between the center of the trim cylinder anchor pin and the stepped face of the gimbal housing as shown to the right. This distance should be 8.684 inches or 220.57 mm.

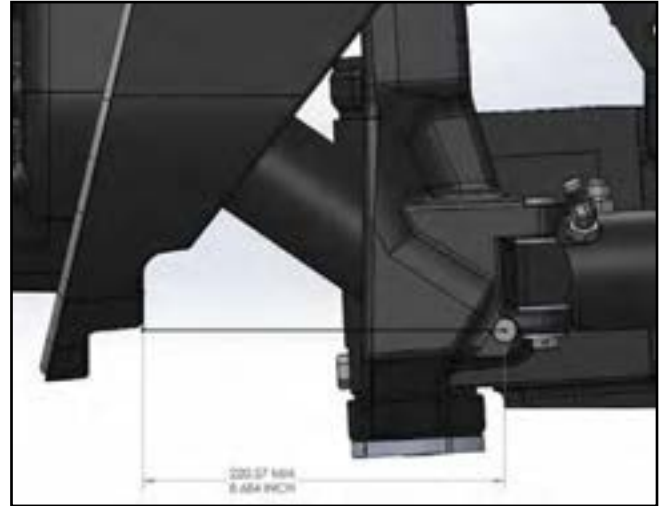

9.11 Once the trim and rudder calibration has been set, the home screen will show both. The trim location is on top, and the rudder location is below on the bottom.

The picture to the right is what a single drive with the default screen will look like.

To access the alternate display, press the down arrow on the directional button.



In a twin installation, the display will look like the one pictured to the right.

Each drive will have its own set of trim control buttons.



## Step 9: Trim Gauge Installation and Programming (continued)

Pressing the left arrow on the directional pad will sync the drives together on a twin or triple install. “Trim All” will appear on the left side of the screen as shown in the picture.

This allows the operator to control the trim of multiple drives with one set of buttons.

To disable this feature, simply press the right arrow on the directional pad.



TS Fail - Is displayed under the trim read out when there is a problem with the trim sensor.

Common issues are: Damaged sensor or wiring  
Loose wires at the trim pump  
Lost connection to the sensor

**NOTE:** This warning is only displayed on the standard screen shown in the picture to the right. The optional screen display will not show this warning.

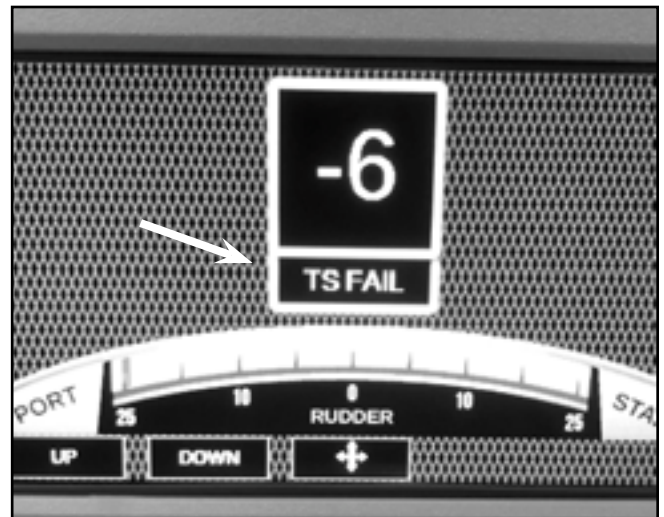

RS Fail - Is displayed under the trim read out when there is a problem with the rudder sensor.

Common issues are: Damaged sensor or wiring  
Loose wires at the trim pump  
Lost connection to the sensor

**NOTE:** This warning is only displayed on the standard screen shown in the picture to the right. The optional screen display will not show this warning.

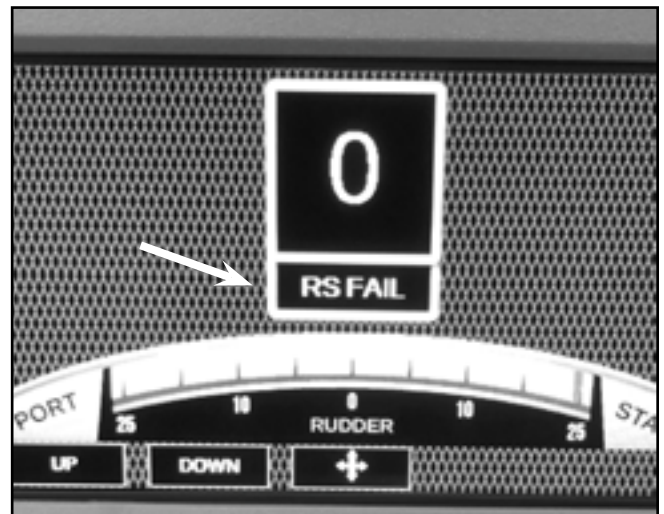

## Step 9: Trim Gauge Installation and Programming (continued)

If the oil reservoir is low on oil, the trim gauge will change over to a red oil warning light, and an image of an oil bottle will appear. Check the oil level in the drive and reservoir, then refill the oil to the appropriate level to avoid serious damage to the drive unit.



Once the drive is trimmed up to its limit in trim mode, (10 degrees) to trim the additional 30 degrees of lift for trailering, continue to press the up button.

The trim readout will change to a red color and the words "Trailer" will appear. **Do Not** operate the vessel in this mode.



To change the display to the optional one shown in the picture to the right, press the directional key pad downward. To return to the standard screen, press the directional key pad downward again.

**NOTE:** *Warnings for trim or rudder sensor failures will not display on this optional screen.*



# Step 10: Steering System Installation

There are many different steering systems available, and because of this the Konrad application engineer takes into consideration many contributing factors to determine which steering system is the best fit for your specific application/vessel.

Examples of some factors include:

- How many drives will be used?
- How is the vessel used?
- Does the vessel turn frequently, such as in a river?
- What type of drives are used (twin prop or single)?
- Will there be multiple helm stations?
- What engines are being used, and do they offer a power steering pump option?

The following pages will contain examples and routing diagrams of our most popular steering systems available for the 600B series drives. Please consult with your Konrad application engineer for the steering system prints, hose routing diagrams, and final approval of the steering system for your application/vessel.



# Steering System Routing Diagram 31-031R (single drive)

DATE	SYM	REVISION	DR

BOTTOM VIEW OF HELM UNIT & PORTS

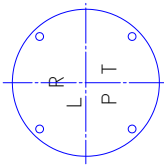

FWD

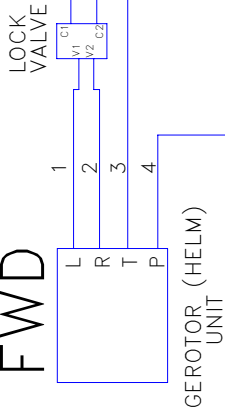

GEROTOR (HELM) UNIT

T-LOW PRESSURE RETURN  
P-HIGH PRESSURE PUMP  
L-LEFT (PORT) CYLINDER LINE  
R-RIGHT (STARBOARD) CYLINDER LINE

**HOSES FOR ELECTRICAL STEERING SYSTEM**

ITEM PART #	Description	QTY
K04-02-000	HOSE, 1/2" 4-JC (FEMALE) SERVO, BOTH ENDS	1
K04-02-000	Ports to LARK Valve #45	1
K04-02-000	HOSE, 1/2" 4-JC (FEMALE) SERVO, BOTH ENDS	1
K04-02-000	Ports to LARK Valve #42	1
K04-02-000	HOSE, 1/2" 4-JC (FEMALE) SERVO, BOTH ENDS	1
K04-02-000	Ports to Electrical Power Steering Pump #22	1
K04-02-000	HOSE, 1/2" 4-JC (FEMALE) SERVO, ONE END/FEMALE 1/4" (M) OTHER END	1
K04-02-000	Electrical Power Steering Pump #22 to Motor #45	1
K04-02-000	HOSE, 1/2" 4-JC (FEMALE) SERVO, BOTH ENDS	1
K04-02-000	Ports to LARK Valve #36 for Steering Cylinder #45	1
K04-02-000	HOSE, 1/2" 4-JC (FEMALE) SERVO, BOTH ENDS	1
K04-02-000	Ports to LARK Valve #36 for Steering Cylinder #45	1
K04-02-000	HOSE, 1/2" 4-JC (FEMALE) SERVO, BOTH ENDS	1
K04-02-000	Ports to LARK Valve #36 for Steering Cylinder #45	1
K04-02-000	HOSE, 1/2" 4-JC (FEMALE) SERVO, BOTH ENDS	1
K04-02-000	Ports to LARK Valve #36 for Steering Cylinder #45	1

TEACHERS NOTE: YOU WILL NEED TO CORRESPOND TO LENGTHS OF HOSE. POWERSTEERING PUMP IS PART # 18 4326 OF 4 HOSE. YOUR PART # IS K04-02-000

PLEASE CORRESPOND YOUR LENGTHS TO THE NUMBERS ON THE DIAGRAM

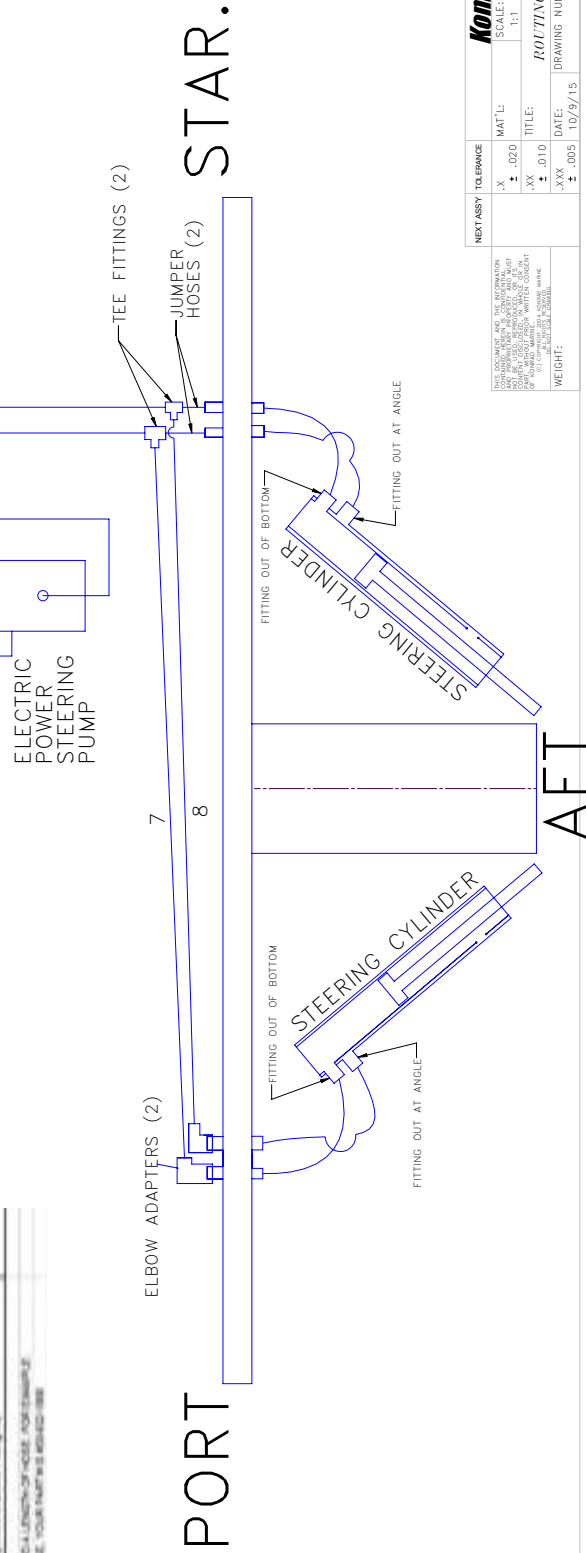

NEXT ASSY TOLERANCE	MAT'L	SCALE	DRAWN BY:
.X	.020	1:1	APP.BY:
.XX	.010	TITLE: ROUTING DIAGRAM	
.XXX	.005	DATE:	DRAWING NUMBER
		10/9/15	31-031R

THIS DOCUMENT AND THE INFORMATION CONTAINED HEREIN IS UNCLASSIFIED EXCEPT WHERE SHOWN OTHERWISE. IT IS THE PROPERTY OF KONRAD INDUSTRIES, INC. AND IS LOANED TO YOU BY THE COMPANY. IT IS TO BE USED ONLY FOR THE PURPOSES AUTHORIZED BY THE COMPANY. IT IS NOT TO BE REPRODUCED, COPIED, OR TRANSMITTED IN ANY FORM OR BY ANY MEANS, ELECTRONIC OR MECHANICAL, INCLUDING PHOTOCOPYING, RECORDING, OR BY ANY INFORMATION STORAGE AND RETRIEVAL SYSTEM. WITHOUT CONSENT FROM KONRAD INDUSTRIES, INC.

WEIGHT:





# Steering System Routing Diagram 31-074R (single drive)

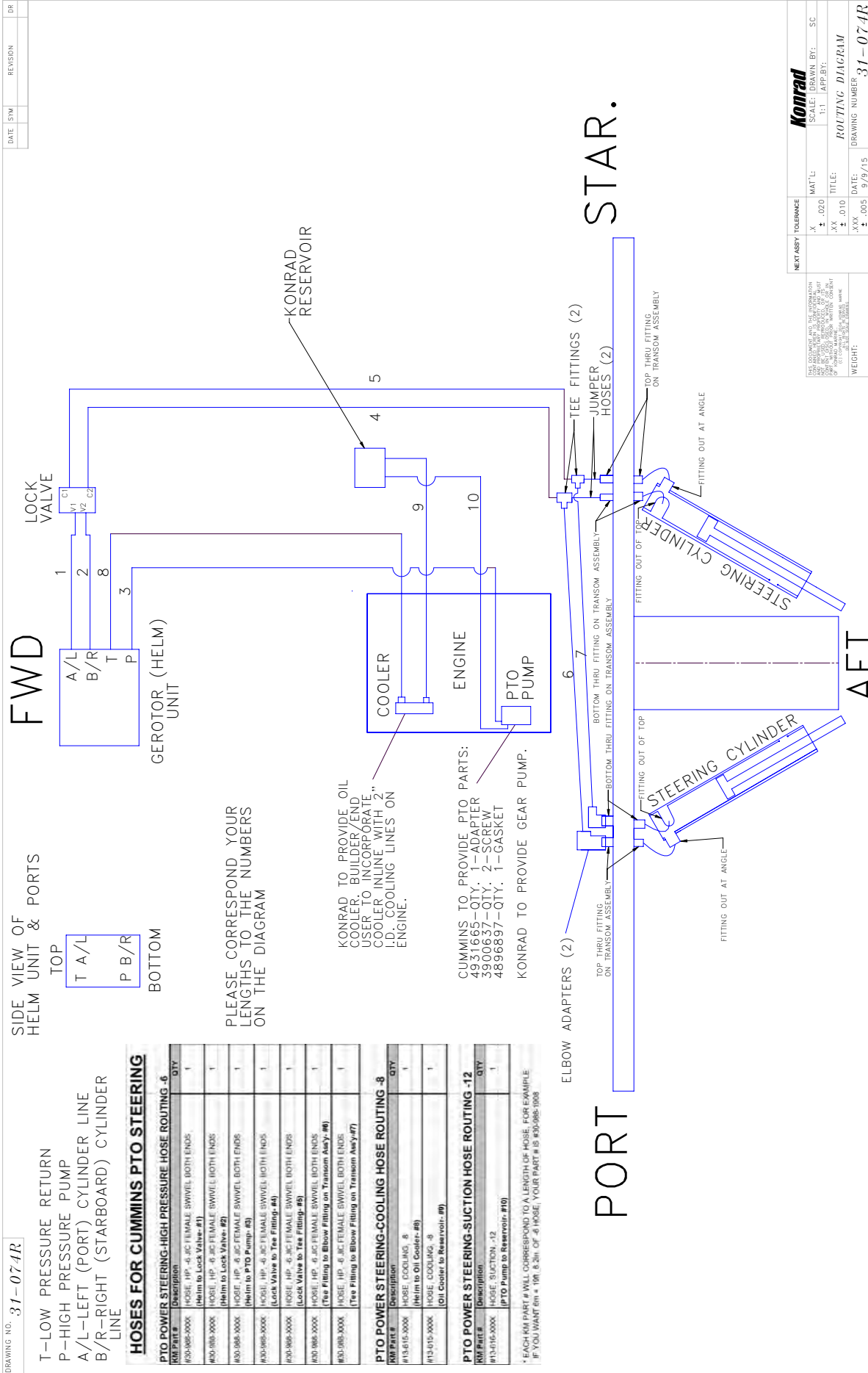

DATE	SYM	REVISION	DR

NEXT ASSY TOLERANCE	MAT'L	SCALE	DRAWN BY:
.XX	.020	1:1	SC
.XX	.010		APPBY:
.XXX	.005		

**Konrad**

TITLE: **ROUTING DIAGRAM**

DATE: 9/9/15

DRAWING NUMBER: **31-074R**





# Steering System Routing Diagram 31-079R (single drive)

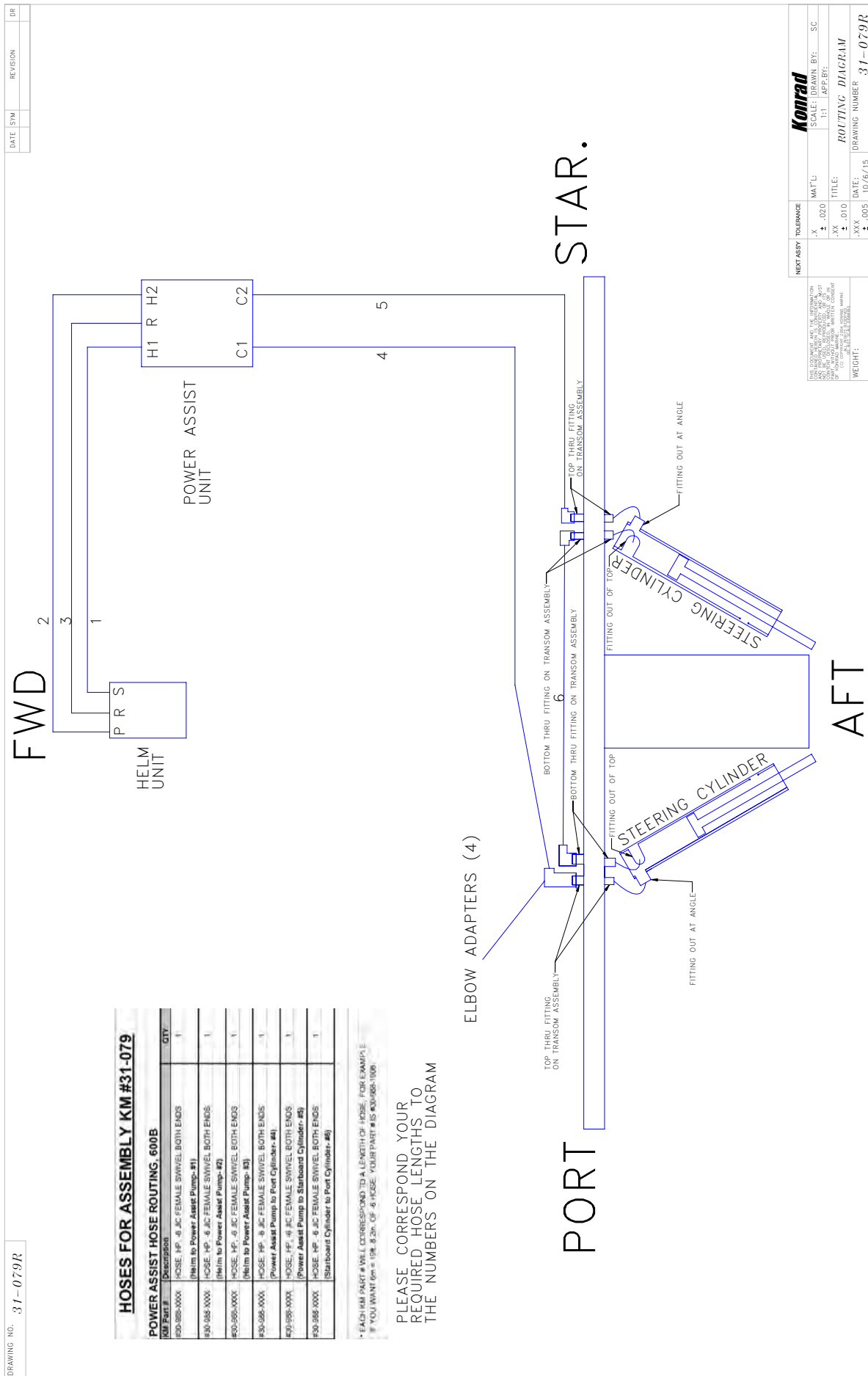

DRAWING NO. 31-079R

DATE:   
 REVISION:   
 DR:

**HOSES FOR ASSEMBLY KM #31-079**

Part #	Description	QTY.
#30-585-XXXX	HOSE, 1/2" ID, 3/8" O.D. FEMALE SWIVEL BOTH ENDS (Helm to Power Assist Pump-#1)	1
#30-588-XXXX	HOSE, 1/2" ID, 3/8" O.D. FEMALE SWIVEL BOTH ENDS (Helm to Power Assist Pump-#2)	1
#30-595-XXXX	HOSE, 1/2" ID, 3/8" O.D. FEMALE SWIVEL BOTH ENDS (Helm to Power Assist Pump-#3)	1
#30-586-XXXX	HOSE, 1/2" ID, 3/8" O.D. FEMALE SWIVEL BOTH ENDS (Power Assist Pump to Port Cylinder-#4)	1
#30-596-XXXX	HOSE, 1/2" ID, 3/8" O.D. FEMALE SWIVEL BOTH ENDS (Power Assist Pump to Starboard Cylinder-#5)	1
#30-589-XXXX	HOSE, 1/2" ID, 3/8" O.D. FEMALE SWIVEL BOTH ENDS (Starboard Cylinder to Port Cylinder-#6)	1

\* EACH PART # WILL CORRESPOND TO A LENGTH OF HOSE. FOR EXAMPLE  
 IF YOU WANT 6m = 19M, 8.2m OF .6 HOSE, YOUR PART # IS #30-585-1908

PLEASE CORRESPOND YOUR REQUIRED HOSE LENGTHS TO THE NUMBERS ON THE DIAGRAM

USE DIMENSIONS AND THE INFORMATION ON THIS DRAWING TO MANUFACTURE THE PARTS LISTED HEREIN. THE PARTS LISTED HEREIN ARE THE PROPERTY OF KONRAD. ANY REUSE OF THESE PARTS WITHOUT THE WRITTEN CONSENT OF KONRAD IS PROHIBITED. ANY PARTS LISTED HEREIN ARE THE PROPERTY OF KONRAD.	NEXT ASSY TOLERANCE	MAT'L	SCALE: DRAWN BY: SC
	.XX	.020	1:1 LAF:BT
	.XX	.010	TITLE: ROUTING DIAGRAM
	.XXX	.010	DATE: 10/16/15
	.005		DRAWING NUMBER 31-079R
			WEIGHT:





# Steering System Routing Diagram 31-080R (twin drive)

DATE	BY	REVISION	DR

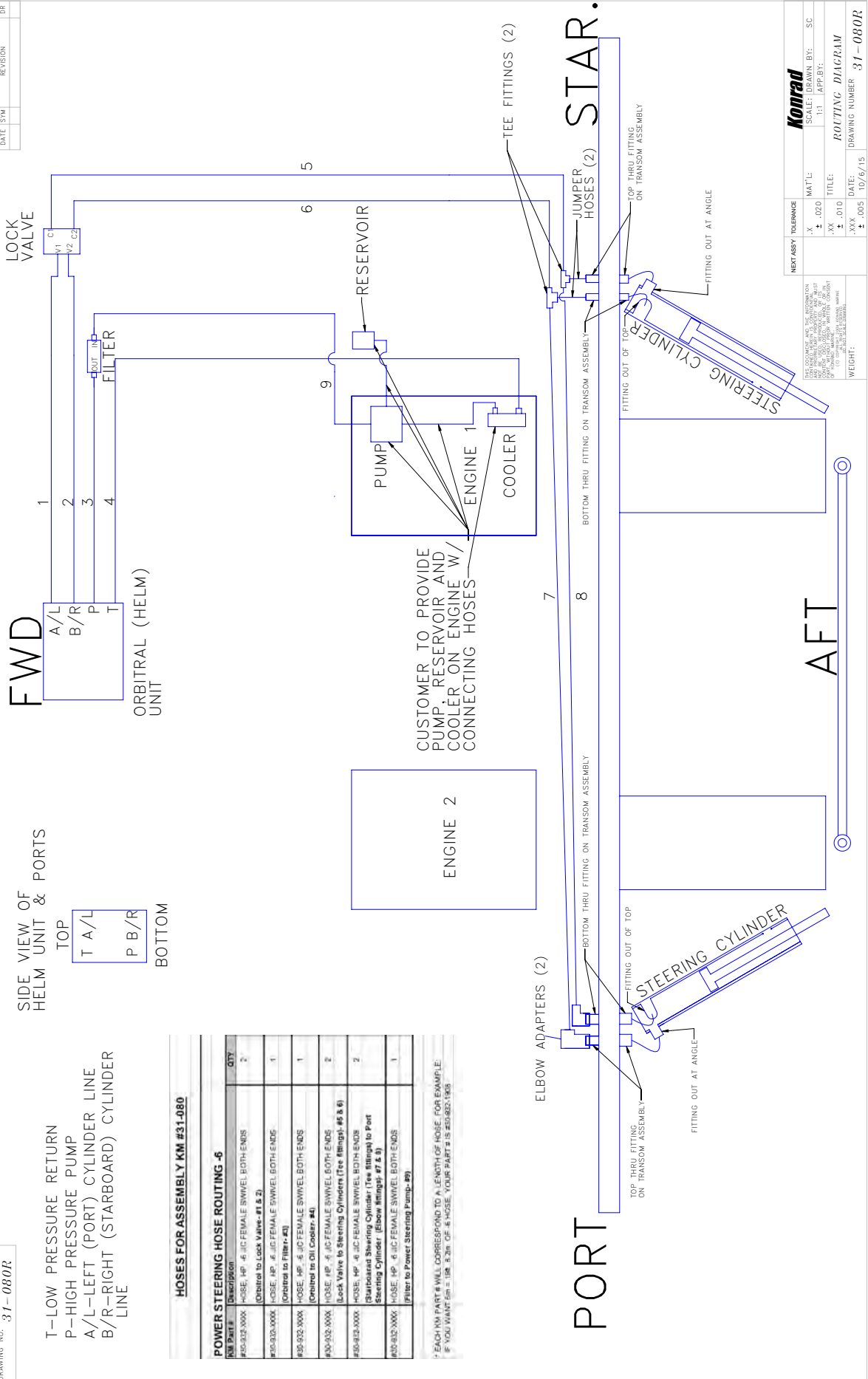

DRAWING NO. 31-080R

SIDE VIEW OF HELM UNIT & PORTS

TOP  
T A/L  
P B/R

BOTTOM  
P B/R

T-LOW PRESSURE RETURN  
P-HIGH PRESSURE PUMP  
A/L-LEFT (PORT) CYLINDER LINE  
B/R-RIGHT (STARBOARD) CYLINDER LINE

**HOSES FOR ASSEMBLY KM #31-080**

Part #	Description	QTY
#05-302-000X	HOSE, HP, .6 IJC FEMALE SWIVEL BOTH ENDS (Optional to Lock Valve #1 & 2)	2
#05-302-000X	HOSE, HP, .6 IJC FEMALE SWIVEL BOTH ENDS (Optional to Filter #3)	1
#05-302-000X	HOSE, HP, .6 IJC FEMALE SWIVEL BOTH ENDS (Optional to Oil Cooler #4)	1
#05-302-000X	HOSE, HP, .6 IJC FEMALE SWIVEL BOTH ENDS (Lock Valve to Steering Cylinders (See fittings #5 & 6))	2
#05-302-000X	HOSE, HP, .6 IJC FEMALE SWIVEL BOTH ENDS (Starboard Steering Cylinder (See fittings #7 & 8))	2
#05-302-000X	HOSE, HP, .6 IJC FEMALE SWIVEL BOTH ENDS (Port to Power Steering Pump #9)	1

\* EACH KM PART # WILL CORRESPOND TO A LENGTH OF HOSE. FOR EXAMPLE: IF YOU WANT 5m = 16ft. 5.2m OF .6 HOSE, YOUR PART # IS #05-821-1905

NEST ASBY TOLERANCE	X	MAT'L	SC
SCALE	1:1	DRAWN BY	SC
TITLE	ROUTING DIAGRAM		
DATE	10/6/15	DRAWING NUMBER	31-080R
WEIGHT			

**Konrad**

# Step 11: Drive Shaft Alignment Procedures

## A) U-Joint Extension Shaft

**Note:** We recommend using a dial indicator to check the transmission flange facial and circumference measurements to ensure all measurements are within .010 in. (.25mm) when rotating the flange.

1. We suggest using tool (TO-186) to bolt onto the flange faces of the transmission and the gimbal housing to make measuring the distances easier.

If aligning without Konrad tool (TO-186) then skip ahead to the NOTES and alignment specifications chart.

2. Place one of the alignment sticks onto the gimbal flange with the beveled edge facing away from the gimbal flange and fasten using two 13-625 H.H.C.S.

3. Take the remaining alignment stick and fasten it to the transmission output flange using two 13-716 bolts and two 11-247 nuts.



## Step 11: Drive Shaft Alignment Procedures (continued)

4. Rotate both flanges until the alignment sticks are in a vertical position..

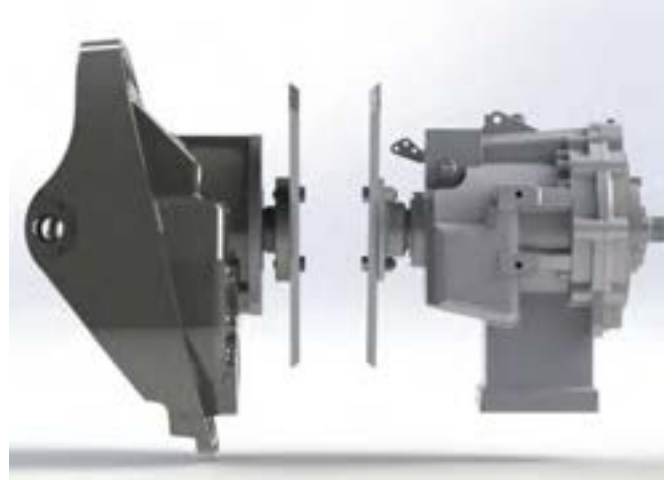

Side view

5. Measure the distance between points A-B, C-D, and A-D, C-B  
Adjust the engine mounts until the measured distance between points A-B and C-D are within .030 inches or .762mm. of each other.

See alignment specifications chart in the following pages.

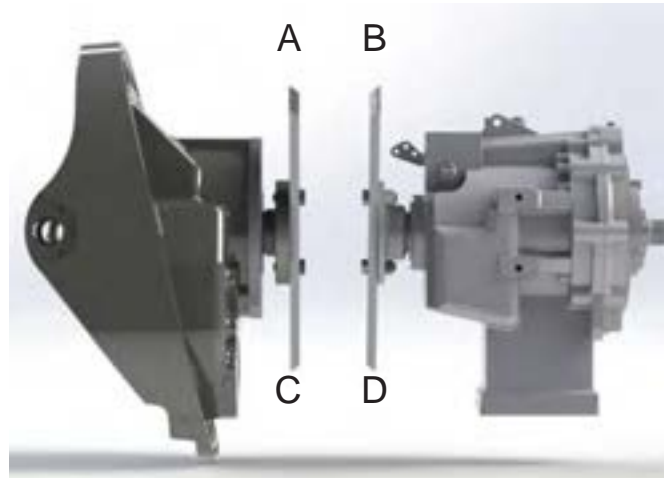

Top view looking down

6. Rotate the flanges until the sticks are horizontal and remeasure points A-B, C-D, A-D, and C-B

Adjust the engine mounts until the measured distances between the points A-B and C-D is within .030 inches or .762 mm. of each other.

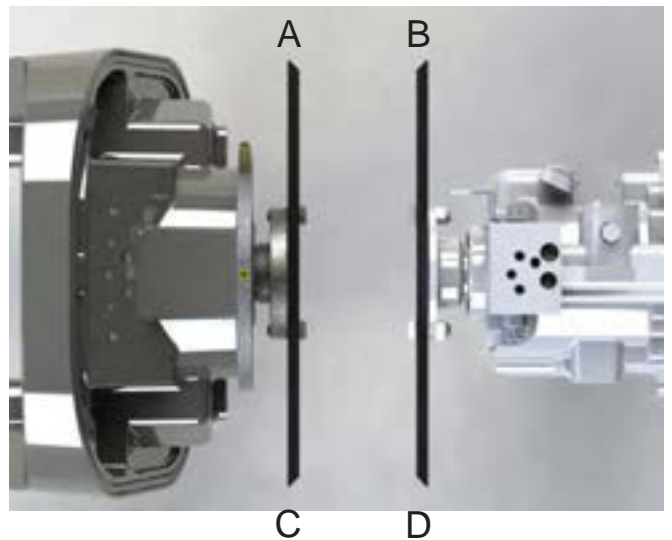

## Step 11: Drive Shaft Alignment Procedures (continued)

**NOTE:** It is recommended to hold either the horizontal or vertical offset at zero and achieve the offset in one plane. In most cases it is easier to hold the horizontal measurement at zero.

7. Adjust the vertical or horizontal offset on measure points, A-D, and C-B.

For a standard Konrad (13-430) 9 inch shaft, adjust the engine mounts until the distances between the two points A-D and C-B is within .047 - .094 inches or 1.19 - 2.39 mm. of each other



If your application is using another shaft, refer to the notes and chart below.

### NOTES:

- 1) Transmission output flange and gimbal carrier input flange must be parallel within .030 in. (.762 mm).
- 2) Transmission output flange and gimbal carrier input flange must have a compounded vertical and horizontal offset angle ( $\alpha$ ) which is  $1.0^\circ > \alpha > 0.5^\circ$ . This dimension is a function of the length of the shaft.
- 3) To determine vertical offset (see picture below)  
(x):  $x = \tan \alpha (y - 3.0 \text{ in.})$  or  
(x):  $x = \tan \alpha (y - 7.62 \text{ cm})$
- 4) Fix magnetic base, arm and dial indicator assembly (GO-017) to transmission output flange.
- 5) Rotate transmission flange indicating the face of the alignment flange. All facial measurements must be within .010 in. (.25 mm).
- 6) Rotate transmission flange indicating the circumference of the alignment flange. All measurements must be within .010 in. (.25 mm). Offset measurements are according to calculation above.
- 7) Refer to Step 12 in this guide for u-joint extension shaft installation.

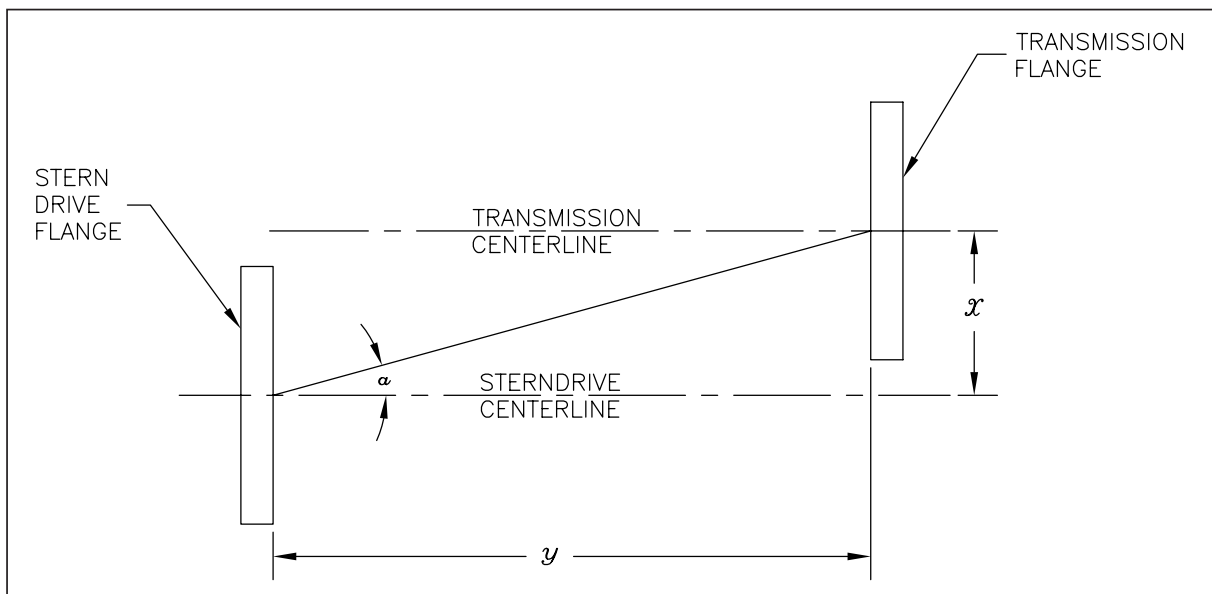

# Step 11: Drive Shaft Alignment Procedures (continued)

## B) CV Extension Shaft

**NOTE:** *The transmission output flange and gimbal carrier input flange must be parallel within two degrees (2°) or manufacturer's approval dependent on power and RPM levels.*

To determine vertical offset for a CV shaft, use the following formula. (see picture on previous page)

$$(x): x = \tan a (y - 5.04 \text{ in.}) \text{ or}$$

$$(x): x = \tan a (y - 12.8 \text{ cm})$$

- 1) The transmission output flange and gimbal carrier input flange must be concentric within the manufacturer's recommended specifications.
- 2) Fix magnetic base, arm and dial indicator assembly (GO-017) to transmission output flange.
- 3) Rotate transmission flange indicating the face of the alignment flange. All facial measurements must be within manufacturer's requirements.
- 4) Rotate transmission flange indicating the circumference of the alignment flange. All measurements must be within the manufacturer's requirements.
- 5) Refer to Step 13 in this manual for CV extension shaft installation.
- 6) The axial distance must be within .0625 in. (1.59 mm) of the shaft's working length (including the adapter flanges).



# Step 11: Drive Shaft Alignment Procedures (continued)

## Alignment Specifications Chart for Transmission to Stern Drive Coupling

Coupling Type	Part #	Length (Range)	Parallelism	Concentricity	Axial Slip Compensation	Coupling Orientation	Tools Suggested	Torque (Fasteners)	Thread Lock Compound	Transmission Type	Stern Drive Carrier Type
Direct (Rear Mount Tailpiece)	30-998	Fixed (Close Couple)	N/A	N/A	Fixed	N/A	TO-189	N/A	N/A	Tail Piece Coaxial	N/A
Constant Velocity (CV)	31-044	>9.5 - <55 in. 25.4 - 140 cm	Max 2°	Max Offset 2°	.0625 in. 1.59 mm	N/A	GO-017 TO-186 TO-187	85 lbs. ft. 115 Nm	Yes	Output Flange	30-999
U-Joint Carden*	13-430	>9 - <60 in. 23 - 152 cm	< .030 in. < .762 mm	Compound Offset between .5° < x < 1°	1 in. 25.4 mm	Yoke Orientation	GO-017 TO-186 TO-187	89 lbs. ft. 121 Nm	Yes	Output Flange	30-999

**\*NOTE:** Grease all splines prior to assembly.



## Step 12: U-Joint Extension Shaft Installation

- 12.1 Verify correct shaft length and installation parameters as defined in the Alignment Specifications Chart (on previous page) and the alignment procedure from Step 11 in this manual before proceeding.
  
- 12.2 If applicable, bolt transmission output flange adapter on to the transmission output flange. Apply *Loctite* to the fasteners before tightening. Torque fasteners correctly according to their size.
  
- 12.3 Bolt u-joint shaft onto gimbal carrier flange. Apply *Loctite* to the four (4) fasteners before tightening. Torque to 89 lb. ft. (121 Nm).

**NOTE:** *Ensure pilot is correctly sized and fully engaged (if applicable).*



## Step 12: U-Joint Extension Shaft Installation (continued)

- 12.4 Adjust u-joint shaft to appropriate length and bolt it on to the transmission output flange (or output flange adapter). Apply *Loctite* to the four (4) fasteners before tightening. Torque to 89 lb. ft. (121 Nm).

**NOTE:** *Ensure pilot is correctly sized and fully engaged (if applicable).*

**NOTE:** *Ensure that the shaft is installed within the working limitations of the slip compensating spline.*

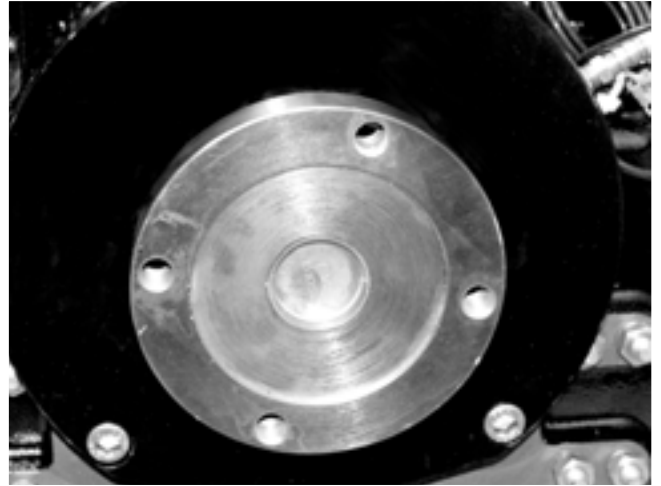

- 12.5 Grease u-joints and extension joint before operation of the shaft occurs.



## Step 13: CV Extension Shaft Installation

- 13.1 Verify correct shaft length and installation parameters as defined in the Alignment Specifications Chart (previously in this manual) and the alignment procedure from Step 11 in this manual before proceeding.



- 13.2 Connect CV adapter flange to gimbal carrier flange. Apply *Loctite* to threads of fasteners. Torque fasteners to 85 lb. ft. (115 Nm).
- 13.3 Connect CV adapter flange to transmission output flange. Apply *Loctite* to threads of fasteners. Torque fasteners correctly according to their size.

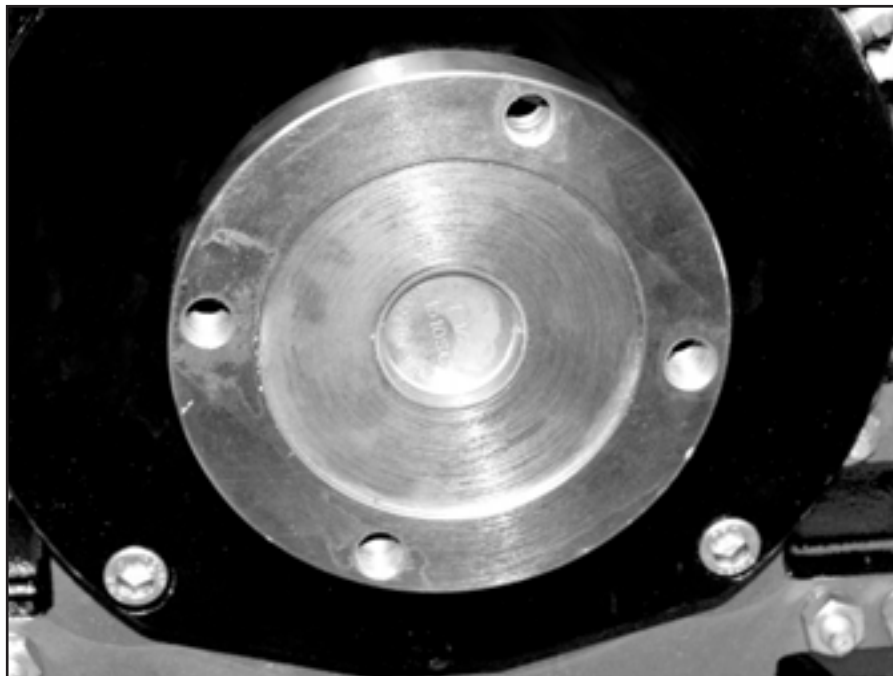

## Step 13: CV Extension Shaft Installation *(continued)*

13.4 Place the CV shaft between the adapter flanges. The shaft may be installed either direction. Fasten the shaft to the adapter flange on the transmission using the six (6) S. H. C. S. and the three (3) 2-hole washer plates provided. Repeat this for the gimbal carrier flange. Apply *Loctite* to the threads of the fasteners and torque to 85 lb. ft. (115 Nm).

**NOTE:** *In some cases only four (4) of the six (6) fasteners can be installed. Inspect adapter flanges prior to shaft installation. In this case insert a plastic plug (provided with shaft hardware) in each of the two (2) holes without a fastener.*

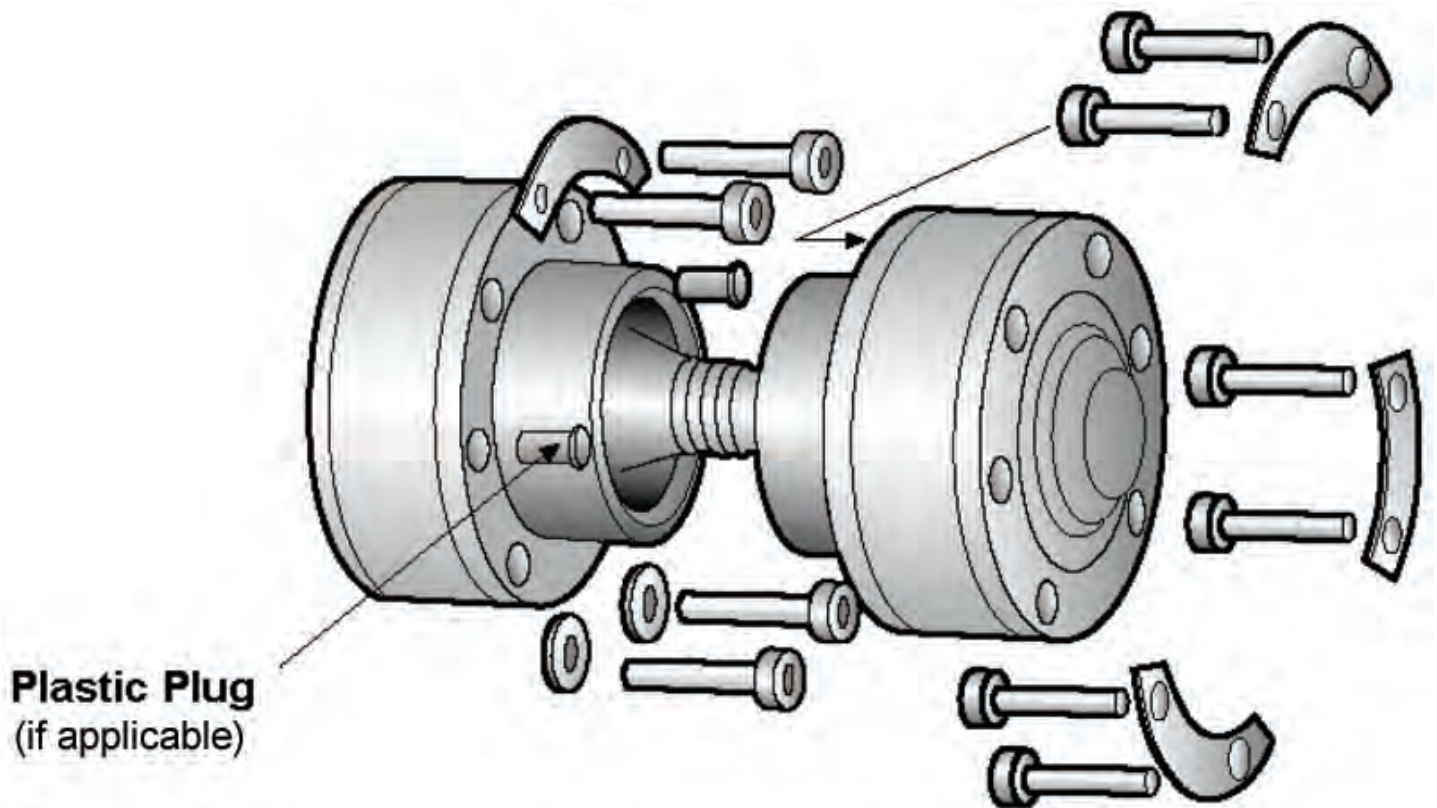

## Step 14(a): 620B Propeller Installation

14.1a Grease and slide thrust washer onto propeller shaft.

**NOTE:** *Tapered end of thrust washer must be towards the drive.*

14.2a Grease splined area and the threads of the propeller shaft.

14.3a Place the propeller on the propeller shaft followed by the appropriate hardware (see below).

14.4a Torque the propeller nut, using a 1 7/16" socket tool, to 80 lb. ft. (109 Nm). When approaching 80 lb. ft. (109 Nm), make sure that the tabs on the tabbed retaining washer (at least 2 out of 6) line up with the grooves in the splined washer/hub.

**NOTE:** *A block of wood can be placed between the propeller and the lower drive housing to prevent the propeller from spinning, while torquing the propeller nut.*

14.5a Bend over the tabs using appropriate tools.

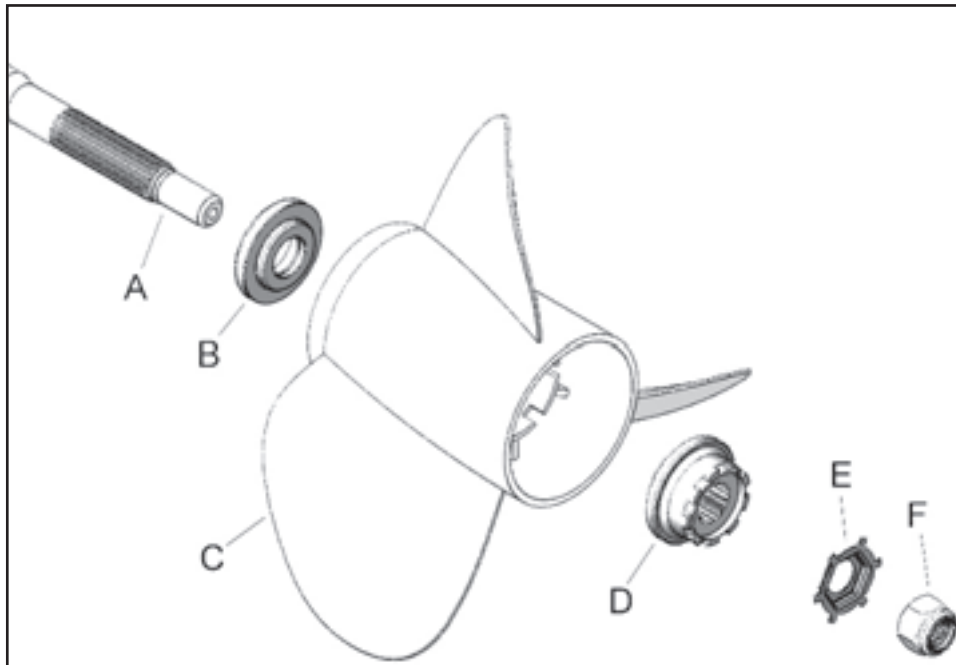

	Description	Qty	Part #
A.....	Prop shaft (L) OR	1	10-360
	Prop shaft (R).....	1	10-363
B.....	Forward thrust hub.....	1	10-292
C.....	Propeller.....	1	variable
D.....	Splined washer.....	1	10-293
E.....	Tab washer.....	1	10-295
F.....	Propeller nut.....	1	10-296

## Step 14(b): 660B Propeller Installation

14.1b Slide forward thrust hub onto forward prop shaft so the tapers meet. Some grease can be used on tapers to hold in place.

14.5b Slide aft thrust hub onto aft prop shaft so the tapers meet. Some grease can be used on tapers to hold in place.

14.2b Grease splined area and the threads of the forward propeller shaft.

14.6b Grease splined area and the threads of the aft propeller shaft.

14.3b Place the forward propeller on the propeller shaft until it seats against thrust hub.

14.7b Place the aft propeller on the propeller shaft until it seats against thrust hub.

14.4b Torque the forward propeller nut to 100 lb.ft. (136 Nm) using hex wrench TO-121.

14.8b Torque the aft propeller nut to 60 lb.ft. (81 Nm) using 1<sup>7</sup>/<sub>16</sub>" socket wrench.

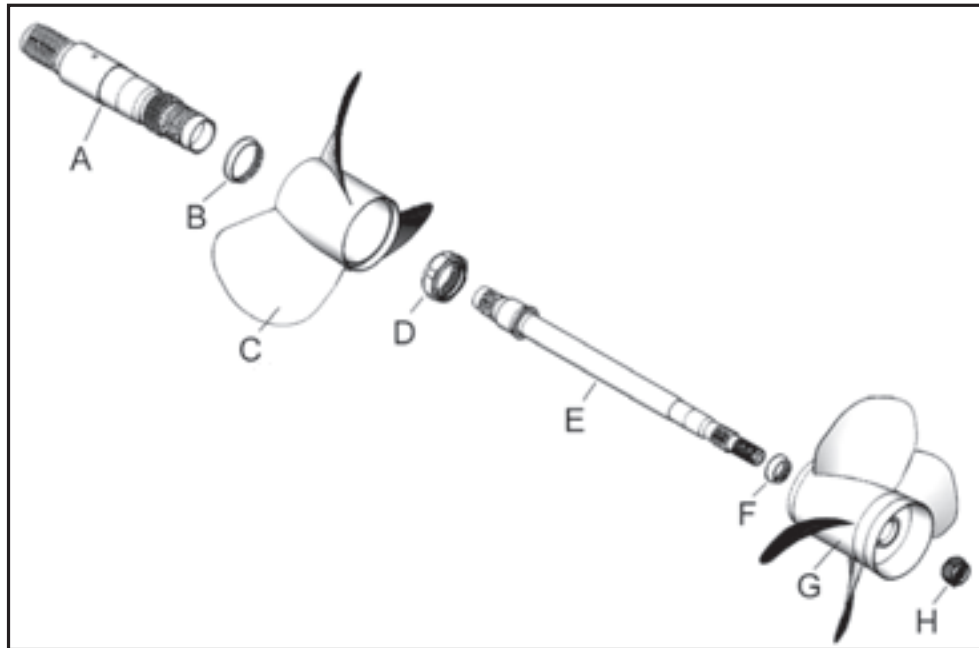

Description	Qty	Part #
A..... Forward prop shaft .....	1	12-502
B..... Forward thrust hub.....	1	12-509
C..... Forward propeller .....	1	variable
D..... Forward prop nut .....	1	12-506
E..... Aft prop shaft .....	1	12-503
F..... Aft thrust hub .....	1	12-508
G..... Aft propeller .....	1	variable
H..... Aft prop nut .....	1	12-529



## Step 14(c): 680B Propeller Installation

14.1c Slide forward thrust hub onto forward prop shaft so the tapers meet. Some grease can be used on tapers to hold in place.

14.2c Grease splined area and the threads of the forward propeller shaft.

14.3c Place the forward propeller on the propeller shaft until it seats against thrust hub.

14.4c Torque the forward propeller nut to 100 lb.ft. (136 Nm) using hex wrench TO-129.

14.5c Slide aft thrust hub onto aft prop shaft so the tapers meet. Some grease can be used on tapers to hold in place.

14.6c Grease splined area and the threads of the aft propeller shaft.

14.7c Place the aft propeller on the propeller shaft until it seats against thrust hub.

14.8c Torque the aft propeller nut to 80 lb.ft. (109 Nm) using 1<sup>13/16</sup>" socket wrench.

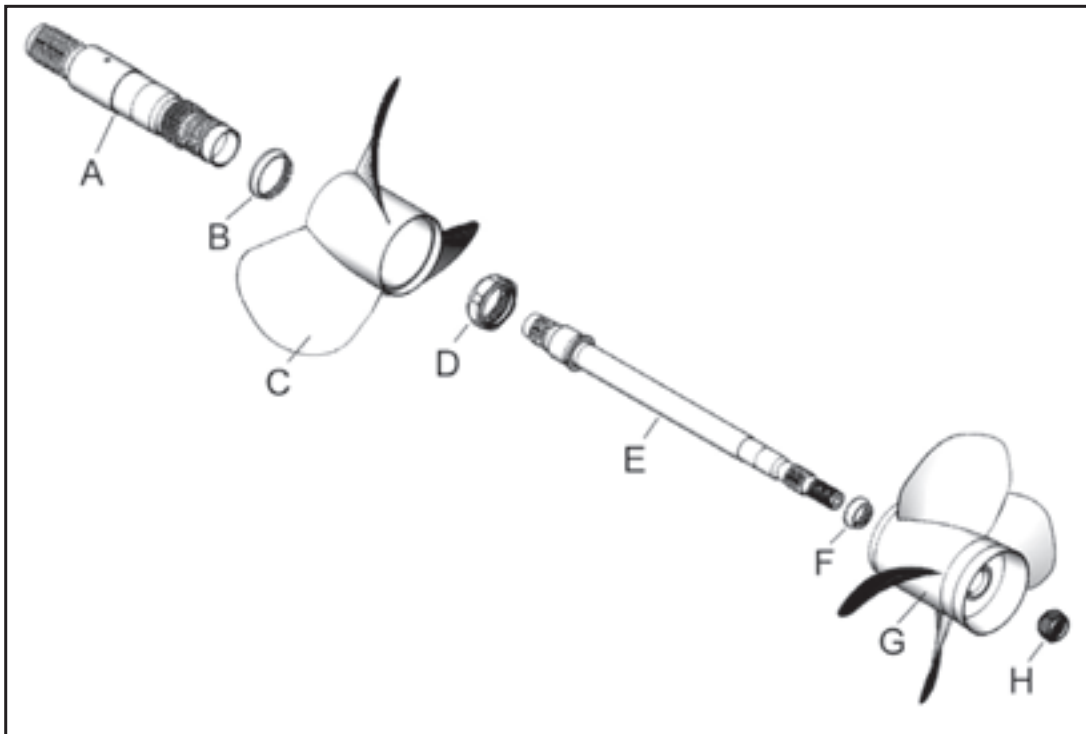

Description	Qty	Part #
A..... Forward prop shaft .....	1	12-705
B..... Forward thrust hub.....	1	12-707
C..... Forward propeller .....	1	variable
D..... Forward prop nut .....	1	12-710
E..... Aft prop shaft .....	1	12-704
F..... Aft thrust hub.....	1	12-708
G..... Aft propeller .....	1	variable
H..... Aft prop nut .....	1	12-716

# Step 15: Installation Review

## Installation Checklist-Inside of Vessel

Please initial when completed:

- \_\_\_\_\_ Verify proper position and level of oil in reservoir bottle. Confirm proper routing of hoses and check all connection points for leaks. Make sure hose is secure to transom a minimum of every 6 inches with fasteners.
- \_\_\_\_\_ Confirm proper amount of ATF fluid (Dexron III) in trim pump and verify proper bleeding of the system.
- \_\_\_\_\_ Check all internal trim cylinder hoses for proper routing and leaks at connection points.
- \_\_\_\_\_ Verify 12V or 24V system of vessel and confirm that proper trim pump has been supplied. Confirm circuit breaker (fuse) is installed on trim pump, and proper gauge wire is being used. Check for proper connection points for wiring of trim pump.
- \_\_\_\_\_ Tilt drives up and down to confirm proper function of trim pump and trim assembly. (Trim Sender) If fitted with mechanical trim senders, verify proper adjustment.
- \_\_\_\_\_ Confirm connection of continuity cable from transom stud to engine or transmission. Also check for continuity from prop shaft of sterndrive to the gimbal assembly, gimbal housing, trim cylinder and steering cylinder.

### Steering:

- \_\_\_\_\_ A) Confirm proper fluid level
- \_\_\_\_\_ B) Verify proper bleeding procedure was done
- \_\_\_\_\_ C) Check all hose routing and connection points for leaks
- \_\_\_\_\_ D) Verify # of turns lock to lock
- \_\_\_\_\_ E) Verify correct rudder indicator position, when compared with the drive position.

### Transmission:

- \_\_\_\_\_ A) Confirm proper fluid level in transmission
  - \_\_\_\_\_ B) Verify proper routing of lines and check for leaks at connection points
  - \_\_\_\_\_ C) Confirm proper orientation of lines and that they are going to the correct ports
  - \_\_\_\_\_ D) (If applicable) Mechanical Shift: Verify proper throw and linkage on mechanical arm.
  - \_\_\_\_\_ E) Check that the Neutral Safety Switch circuit is correct
- \_\_\_\_\_ Confirm that engine mounts/vibration isolators (on stringers) are within angular and height tolerance.

### Drive shaft - If applicable

- \_\_\_\_\_ A) Confirm Parallelism and Concentricity meet Konrad requirements for specific shaft type and length. Reference Step 11 in this manual for information.
- \_\_\_\_\_ B) Confirm proper torque on hardware at both drive and transmission connection. Also, verify that Loctite was used where recommended.

## Step 15: Installation Review (continued)

### Installation Checklist-Outside of Vessel

Please initial when completed:

- \_\_\_\_\_ Verify Serial #'s on drives for proper ratio and rotation.
- \_\_\_\_\_ X-Dimension: Confirm proper height. Verify from application drawing.
- \_\_\_\_\_ Confirm propeller specs for correct diameter and pitch.
- \_\_\_\_\_ Verify that alignment was done correctly for close couple or remote mount per your install type.
- \_\_\_\_\_ Confirm proper oil level in sterndrives.
- \_\_\_\_\_ External Steering: Confirm torque specs on fasteners. Steering rams, tie bars, etc...
- \_\_\_\_\_ Twin applications: Confirm centerline distance of drives on transom and take measurement from center to center on propshafts to make sure drives are in-line.
- \_\_\_\_\_ Inspect all hoses and fittings on trim and steering lines for any leaks at connection points and also proper routing of hoses.
- \_\_\_\_\_ Confirm proper orientation of bellows and check for secure connection on drive and gimbal assembly. Tighten hose clamps.
- \_\_\_\_\_ Check for continuity from prop shaft of sterndrive all the way to the gimbal assembly, including the gimbal housing, trim cylinders, and steering cylinders.
- \_\_\_\_\_ Check stern drive for side to side play. The movement should be minimal to none.
- \_\_\_\_\_ Check for proper continuity on drive from prop shaft to transom using a volt meter.
- \_\_\_\_\_ Verify correct adjustment of electrical trim senders.
- \_\_\_\_\_ Inspect bottom of hull for any protrusions impeding clean water flow to propellers. Ex. Transducers, water pickups, anodes, etc...(See drawing in Installation Guidelines section)
- \_\_\_\_\_ Inspect mounting area of transom for flatness and correct 13° degree mounting angle.

Prepare vessel for sea trial, fill out Application Trial Data Forms on following pages. Send in Konrad Warranty Registration and sea trial forms to Konrad Marine.

# Trim System Component Overview and Troubleshooting

## Components

### Displays

#### **Primary (13-544)**

**Secondary (13-679)** only used in dual helm applications.

- Part numbers are scribed on back of displays.
- Receives CAN messages from Module
- Secondary display does not have any internal memory and gets it's signal from the primary display.



### Modules

#### **Single (13-543)**

**Twin (Port 13-543, Starboard 13-697)**

**Triple (Port 13-543, Center 13-697, Starboard 13-698)**

- Part numbers are scribed on top of Module
- Part number coincides with orientation
- Analog signals get transferred to CAN-BUS
- Light on module should blink rapidly when operating properly
- If the light blinks at a slow rate about every 3 seconds, check to ensure that no CAN lines are disconnected.



### Trim Pumps

**12 Volt (31-063)**

**24 Volt (31-064)**

- One pump per drive
- Not orientation specific
- Hub where analog signals get sent to Module



# Trim System Component Overview and Troubleshooting

*(continued)*

## Keypads

**Primary (13-610)**

**Secondary (13-700)** only used in dual helm applications.

- Keypad pictured is for Triple applications only (Trim Control)

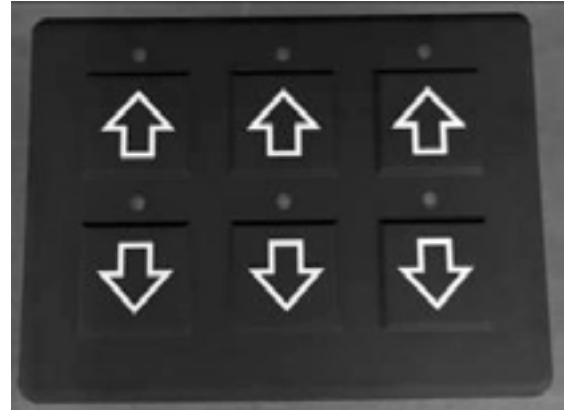

A basic knowledge of Control Area Network (CAN) line construction is mandatory to trouble shoot and repair damaged or broken CAN lines. Sometimes referred to as J1939, twisted pair, or distributed system.

Each CAN line is made up of a backbone (trunk), Y connectors, and differential twisted pair wires leading from the Y connector to the module.

## Backbone (Trunk)

The backbone of a CAN line runs from one terminating resistor to the other terminating resistor linking all modules together creating a path of communication throughout the entire boat.



## Y Connector

Each Y connector has three connecting points. The O (rounded) is the connecting point for additional modules. The X (triangle) is the connection point for additional CAN line or the terminating resistor.

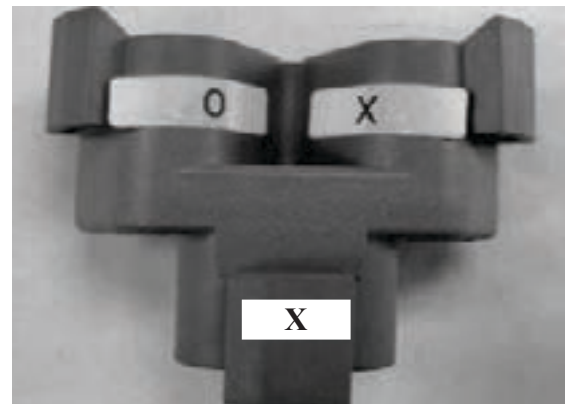

# Trim System Component Overview and Troubleshooting

*(continued)*

## Y Connector (continued)

Looking down at the connector, there is a male rounded post (O) surrounded by three pins (A, B, C). On the other side is a male triangle (X) surrounded by three pins (A, B, C).

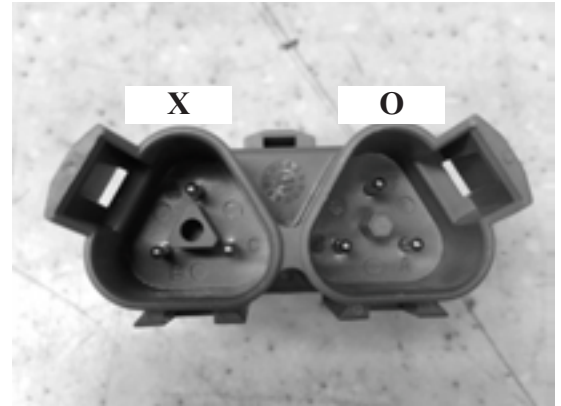

## Y Connector (continued)

Each Y Connector is connected together creating the backbone of the CAN line. The X or backbone connection wire will have a blue colored female triangular wedge lock. .



## Y Connector (continued)

Each Y Connector has a rounded post connection point for all modules used on the truck. The O or module connection wire, will have an orange colored female round wedge lock. .



## Backbone Wire

The backbone wires consists of:

- A red wire CAN HIGH pin B
- A black wire CAN LOW pin A
- A tinned copper wire CAN shield pin C (not typically needed).





# Trim System Component Overview and Troubleshooting

## (continued)

### Backbone Wire (continued)

Each end of the backbone (trunk) is terminated with one 120 OHM resistor. These resistors must be in place for proper CAN line operation.

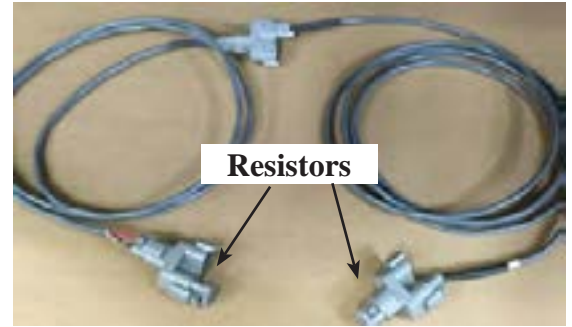

### Error Codes

Error codes are displayed under the digital trim angle readout on the standard screen only.

- Closs - Communication error between the module and display once in operation.
- RS Fail - Rudder sensor signal failure.
- TS Fail - Trim sensor signal failure.



### Dual Displays

Secondary display (13-679) screen turns all blue in color and reads “Communication loss with control module”. Make sure that the primary display is turned on.

If the primary display is turned on, and the message is displayed, check the wiring between the two displays for a good connection.

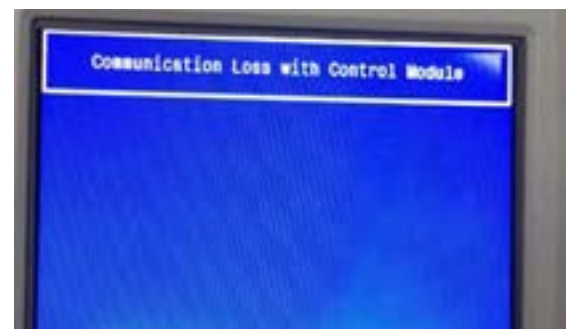

# Trim System Component Overview and Troubleshooting (continued)

## Trouble Shooting the CAN line

1. Make sure that all modules in the system have power and a heart beat (blinking light). Modules that have a heart beat, but are not communicating need to have the CAN line checked. Use the corresponding schematic for the system installed to identify the connections, routing and options.

**Note:** For every module on the trunk, there will be a Y connector. The two Y connectors with terminating resistors define the two end points of the CAN line. When both terminating resistors have been located, follow the steps outlined below to check each terminating resistor for the proper ohms value.

2. Remove the terminating resistor from the Y connector.

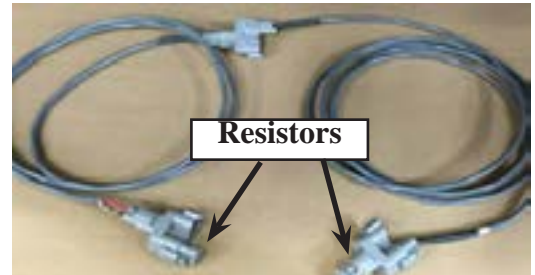

3. Remove the blue wedge lock from the resistor using a screw driver or pick. Using an ohm meter measure across the two pins of the resistor.

A good terminating resistor will have readings of 119.6 or 120 ohms, replace a resistor if the ohm reading is less.

Reinstall wedge lock if resistor tests okay and reinstall in Y connector.

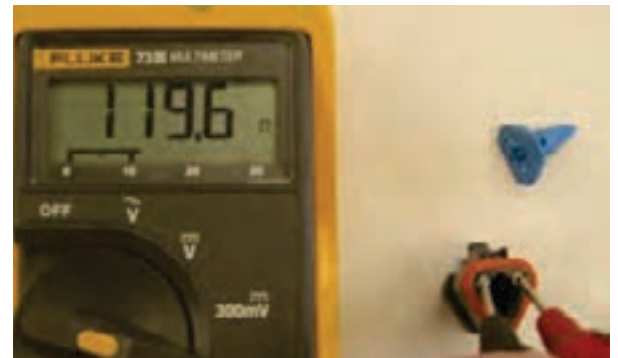

Once the terminating resistors are tested okay, next step is to isolate the CAN wire.

With both terminating resistors in place wired in parallel, the total resistance of the can line should be 60 ohms when tested at the open connector at each end of the Y connector.



# Trim System Component Overview and Troubleshooting

## (continued)

1. Disconnect the module at the Y connector with the terminating resistor.
2. Remove the wedge lock from the connector and measure the resistance.
3. If a reading of 59.9 or 60 ohms is measured, that portion of the CAN line is okay.
4. If a reading is 119 or 120 ohms is measured, the CAN line is broken a head of the point where the terminating resistor is placed. The easiest way to trouble shoot a broken CAN line is to shorten the CAN line. This is done by removing the terminating resistor and moving it up to the next Y connector and placing it back in the CAN line.



5. Go back to step 2 once the line is shorten and remeasure the ohms in the CAN line. If the reading is 119 to 120 ohms then the line is broken ahead of the point where the terminating resistor is placed, repeat step 4.
6. If the measured reading is 59.9 or 60 ohms the break in the CAN line is in the part of the can line that was unplugged
7. Once the area of the brake is identified, measure each wire through the connectors. Measure pin A to pin A, and pin B to pin B, then pin C to pin C if applicable.

If an ohm reading is seen on the multimeter, the wire is good. If no reading is seen, then the wire has a break and needs repair or replacing.

8. When the break has been repaired, closely inspect all connectors, pins, and wires for damage. Place the terminating resistor back in its original position and remeasure the Can line. A good can line will read 59-60 ohms at the module connections indicating the line is operational.



9. Recheck the functions assigned to that module for correct operation.

# Trim System Component Overview and Troubleshooting

## (continued)

### Troubleshooting a Trim or Rudder sensor.

If either RS or TS Fail warning appears, you may have lost connection to one of the sensors, or the sensor may have been damaged.

1. Remove the trim pump cover and with the trim system turned on, test with a multimeter the voltage of the yellow wire for the sensor that you are checking. The trim sensor will be in position 4 and the rudder sensor will be in position 3. A voltage reading of 0 is bad. Voltages should be between 1 and 5.



2. When testing voltages, if the voltages jump instead of showing an even, smooth change. It is possible that the sensor shaft or sensor magnet is out of position. This is especially common when the drive has been recently removed or a sensor has been replaced.

Check the sensor to see that the small indent (above the shaft slot) or the small notch on the magnet is aligned with the wire harness at the top of the sensor.

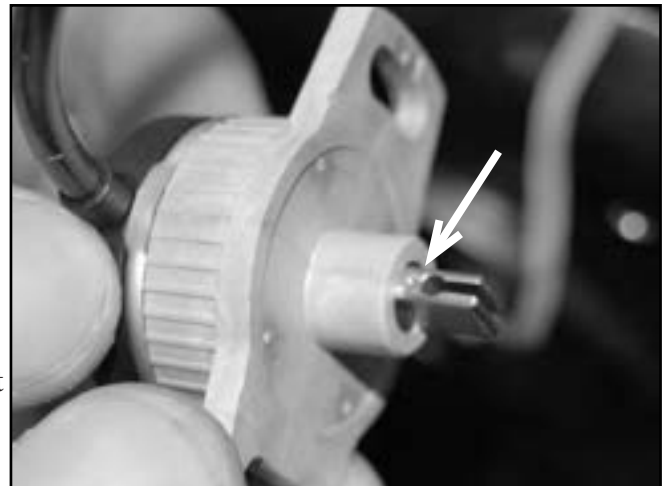

For further assistance, please call the factory 1-800-927-3545.





### KONRAD APPLICATION TRIAL DATA FORM

DEALER or DISTRIBUTOR COMPANY NAME \_\_\_\_\_ PROJECT NAME/NUMBER: \_\_\_\_\_  
 DEALER or DISTRIBUTOR CONTACT NAME \_\_\_\_\_ CLIENT NAME: \_\_\_\_\_  
 DEALER or DISTRIBUTOR EMAIL: \_\_\_\_\_ DATE: \_\_\_\_\_

**CHART 1**

**CONDITION DESCRIPTIONS**

*Please circle the unit of measure ( KG ) or ( LBS ) you are using for entries with weights*

CONDITION	DATE	STERN DRIVE MODEL	DRIVE RATIO	TRANS-MISSION MAKE & MODEL	TRANS-MISSION RATIO	X-DIM	SPACERS	ENGINE HP @ RPM	VESSEL RUNNING WEIGHT (no fuel)	FUEL WEIGHT	PERSONNEL AND / OR CARGO WEIGHT	VESSEL TOTAL RUNNING WEIGHT	PROP MFG	NUMBER OF BLADES	DIAMETER & PITCH	PROP MATERIAL (AL or SS)
1																
2																
3																
4																
5																
6																
7																
8																



## KONRAD APPLICATION TRIAL DATA FORM

VESSEL MAKE: \_\_\_\_\_ HULL TYPE: Catamaran / Monohull (Circle)

VESSEL LENGTH: \_\_\_\_\_ APPLICATION: Single / Twin (Circle)

**CHART 2 TRIAL DATA FOR MAX VELOCITY AT VARIOUS CONDITIONS (OUTLINED IN CHART 1)**

CONDITION (See Chart 1 for Description)	ENGINE NO LOAD MAX RPM (NEUTRAL)		TRIM POSITION	MAXIMUM VELOCITY READINGS						ENGINE EXHAUST TEMP(C°) AND LOAD %	ENGINE BOOST PRESSURE (kPa)			
	Port	Star		TIME TO PLANE (SEC.)	ORIGINAL HEADING (0°)		VELOCITY MAX (KTS)	OPPOSITE HEADING (180°)						
					RPM (ENGINE)	Star		RPM (ENGINE)	Star					
1														
2														
3														
4														
5														
6														
7														
8														
<b>GPS Speeds at Varying RPM</b>														
RPM		GPS @ Idle		GPS @ 1000		GPS @ 1500		GPS @ 2000		GPS @ 2500		GPS @ 3000		GPS @ WOT
Knots														





## KONRAD APPLICATION TRIAL DATA FORM

VESSEL MAKE: \_\_\_\_\_ HULL TYPE:          Catamaran / Monohull (Circle)

VESSEL LENGTH: \_\_\_\_\_ APPLICATION:          Single / Twin (Circle)

### CHART 2 TRIAL DATA FOR CRUISE VELOCITY AT VARIOUS CONDITIONS (OUTLINED IN CHART 1)

CONDITION (See Chart 1 for Description)	ENGINE NO LOAD MAX RPM (NUETRAL)		TIME TO PLANE (SEC.)	TRIM POSITION	CRUISE VELOCITY READINGS - MINIMUM 3 READINGS, 200 RPM INCREMENTS				ENGINE EXHAUST TEMP(C°) AND LOAD %	ENGINE BOOST PRESSURE (kPa)
	Port	Star			ORIGINAL HEADING (0°)		OPPOSITE HEADING (180°)			
					VELOCITY CRUISE (KTS)	RPM (ENGINE) Port	Star	VELOCITY CRUISE (KTS)		
1										
2										
3										
4										
5										
6										
7										
8										
<b>GPS Speeds at Varying RPM</b>										
RPM	GPS @ Idle	GPS @ 1000	GPS @ 1500	GPS @ 2000	GPS @ 2500	GPS @ 3000	GPS @ WOT			
Knots										





## **KONRAD MARINE, INC.**

1421 HANLEY ROAD • HUDSON, WI 54016-9376 USA

Phone: 715-386-4203 • Toll Free: 1-800-927-3545 • Fax: 715-386-4219

[www.konradmarine.com](http://www.konradmarine.com)